

Marksman Duo XT Pro-Series



High Resolution Printing
for the **Real World**

Operations Manual

5765-313
Revision D



www.foxjet.com

Duo HR Controller

Section 1: Introduction	1
Section 2: Safety	2
Section 3: System Components	3
Section 4: Installation, Porous Print Heads	7
Installing Pro Series 384 and 768 Porous Print Heads	9
Priming the Print Heads	11
APS Cycle	11
Encoder	13
Section 5: Installation of Non-Porous Print Heads	14
Print Head Tilt	15
Electrical Cable Connections (384 NP)	16
Plumbing the System (NP384)	17
Priming NP384 Print Heads Using the Auto-Prime and ACS Cycles	23
Section 6: Getting Started	25
Keypad	25
Home Screen	26
Section 7: Setup Functions	29
Configuring the Print Station	29
Serial Port Setup	32
Network Setup	34
Time & Date Screens	36
Section 8: Message Functions	38
Creating a Print Message	38
Editing a Message	48
Estimating Ink Consumption	51
Printing a Message	51
Deleting a Message	51
Making Adjustments During Printing	51
Section 9: Utility Functions	53
User Access Control	53
Status Screen	56
System Test	57
Regional Settings	58
System Reboot	58
File Operations	59
Section 10: Maintenance	61
System Maintenance	61
Print Head Maintenance, ScanTrue II Porous Ink	61
ACS - Automatic Cleaning System	65
Pro Series IS Maintenance	67

Duo HR Controller

Section 11: Trouble Shooting	68
Marksman Duo XT controller:	68
Pro Series IS:	69
Pro Series 384 NP Print Head	71
Appendix A: Specifications	76
Controller	76
Print Head Specifications (Porous)	78
Pro Series 384NP Print Head	79
Pro Series IS	81
SCS (Smart Cleaning System) Photosensor	82
Automatic Air Knife	82
Ink	82
Waste Bottle	82
Encoder	82
Encoder Pin Out for NP & Pro Series Interface Boards	83
Appendix B: Parts and Supplies	85
Controller Battery	85
Controller Assembly Kits	86
Consumables	86
Print Head Cleaning	86
Print System Service Kits	87
Pro Series IS Assembly Kits	89
Fittings and Tubing	92
Appendix C: Performance Parameters	93
Appendix D: Communicate with Controller Via PC	95
Windows 7®	95
Windows XP®	97
Appendix E: Creating a Logo	101
Appendix F: Standard Operating Procedures	105
FJSOP1 - Removal of FoxJet High Resolution Print Heads	105

Section 1: Introduction

This manual describes the operation of the Marksman Duo controller. It includes programming instructions to create and edit print messages for the controller. The Duo controller is used in conjunction with the Pro-Series Print heads.

This manual covers the operation of the Marksman© Duo Ink Jet Printing System, Marksman© Duo Controller and Print Heads.

The Marksman Duo XT Controller can be configured, via different interface PC boards, for use with either Porous print heads (Pro-Series 384 and Pro-Series 768) or Non-Porous print heads (Pro-Series 384NP). The Controller can also be expanded by adding a second interface PC board allowing for a second Task.

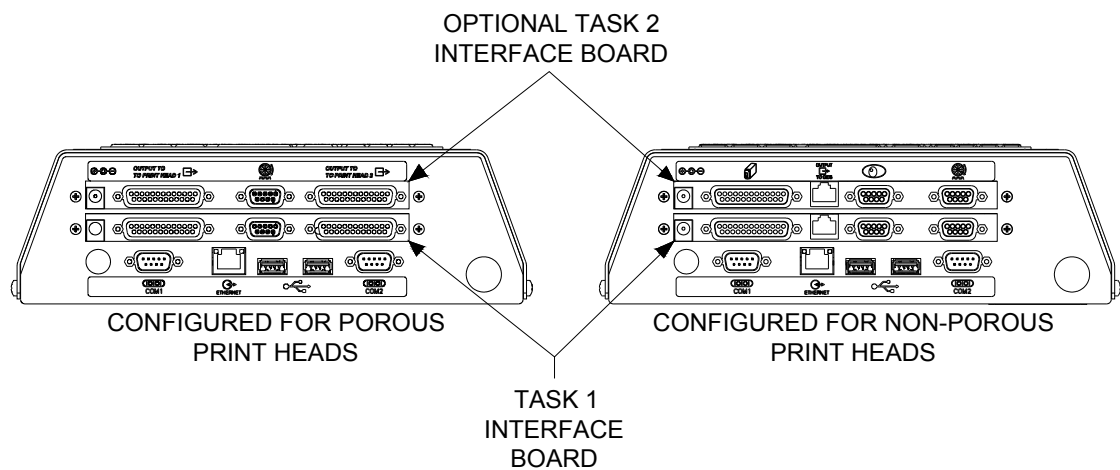

CAUTION: Never mix ink types because they are not miscible. Irreversible internal damage will occur.

Section 2: Safety



Wear safety goggles when performing the procedure described!



Caution or Warning! Denotes possible personal injury and/or damage to the equipment.



Caution or Warning! Denotes possible personal injury and/or equipment damage due to electrical hazard.



NOTE: (Will be followed by a brief comment or explanation.)



CAUTION: The Pro-series IS Ink Delivery System contains hazardous voltage (115/230VAC). Turn off the equipment's main power before:

- Performing preventive maintenance.
- Performing any repairs to the unit.
- Servicing the equipment in any manner.

ESD protection should be worn when servicing internal printed circuit boards.

After service to the equipment is completed, replace all protective devices such as grounding cables and covers before operating the equipment.

Only trained personnel should operate and service the equipment.



NOTE: It is extremely important to:

- Clean up all ink spills with the appropriate conditioners immediately and dispose of all waste according to local and state regulations.
- Wear safety glasses and protective clothing, including gloves, when handling all inks and conditioners.
- Store inks and conditioners under the recommended conditions found on the MSDS (Material Safety Data Sheet).



PRODUCT COMPLIANCE DISCLAIMER NOTE:

This product meets the requirements of CAN/CSA-22.2 NO.60950-00 * UL 60950 using FoxJet an ITW Company approved items. Units are only tested and qualified with FoxJet an ITW Company approved inks, parts and accessories. Use of other inks, parts or accessories may introduce potential risks that FoxJet an ITW Company can assume no liability for.

Section 3: System Components

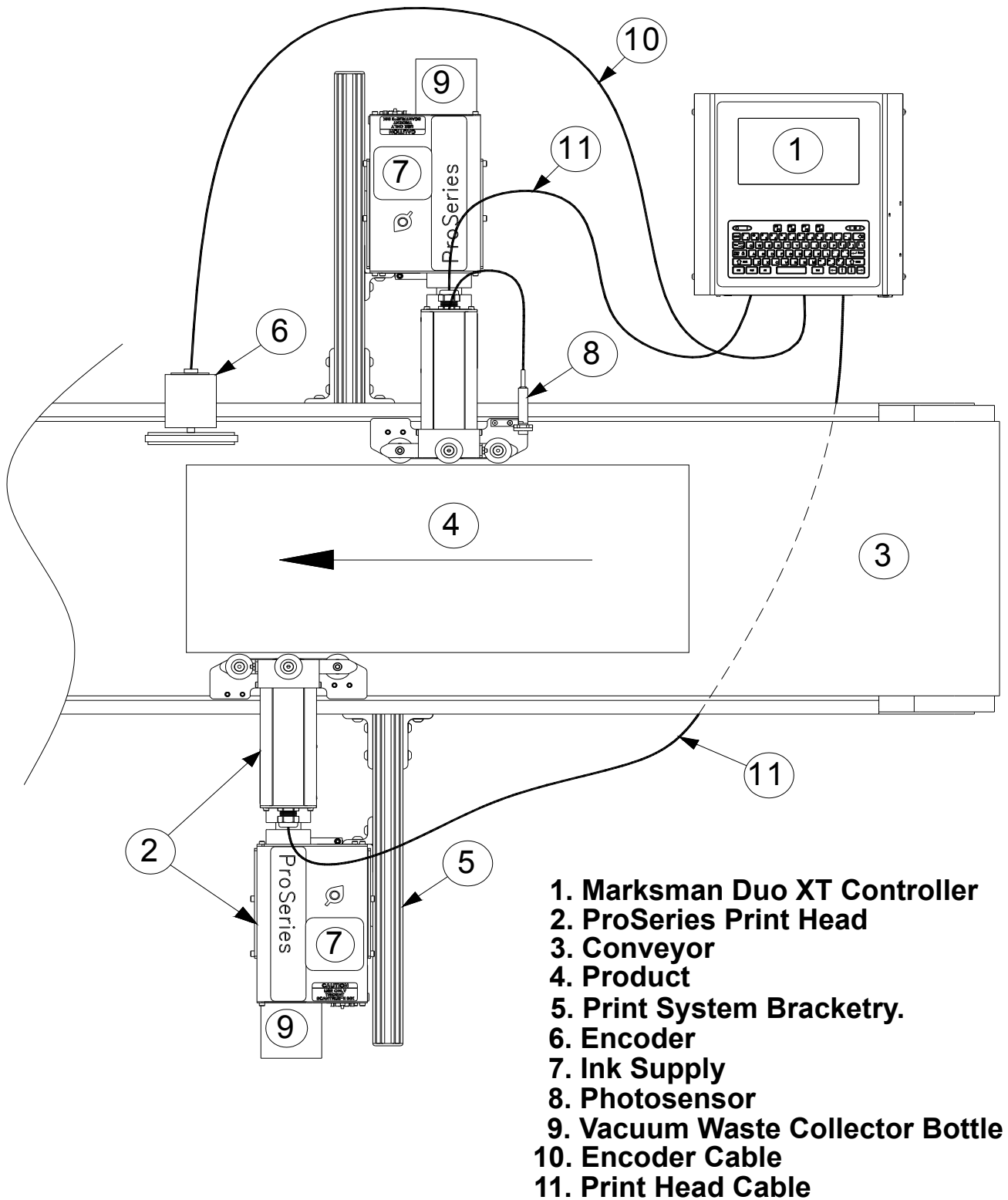

System Components, Non-Porous

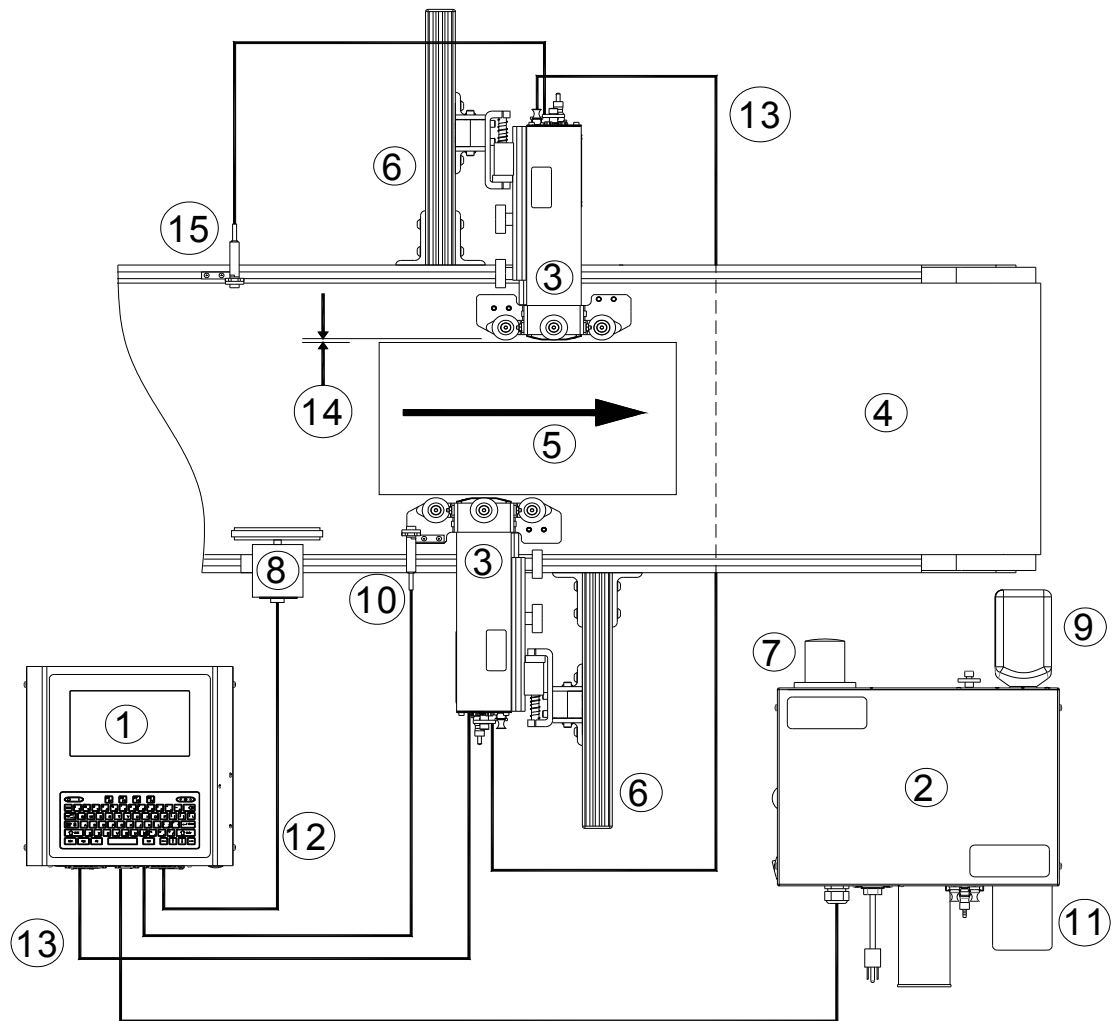

- | | |
|-------------------------------|---|
| 1 Marksman Duo XT | 10 Photo Sensor |
| 2 ProSeries IS | 11 Vacuum Waste Collector Bottle |
| 3 Print Heads | 12 Encoder Cable |
| 4 Conveyor | 13 Print Head Cable |
| 5 Product | 14 Throw Distance |
| 6 Print Head Bracketry | (1/6" Recommended) |
| 7 Ink Status Beacon | 15 SCS Photocell |
| 8 Encoder | |
| 9 Ink Supply | |

The Marksman Duo XT Ink Jet System is available with the following Components, options, and service kits.

Part Number Description

Standard Porous & Non-Porous Print Heads

5760-032384NPFX	Pro Series 384 NP Print Head, AllWrite A5000
2464-034	Pro Series 384, Integrated w/APS, ScanTrue II®
2464-025	Pro Series 768, Integrated w/APS, ScanTrue II®

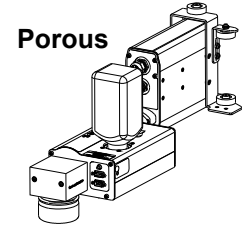
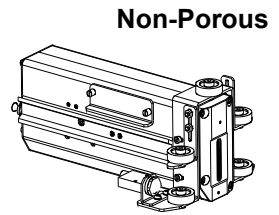

**Pro Series IS Non-Porous System w/SCS
(Includes Tubing Kit)**

5765-005AFSA5FX	Stainless Enclosure, Domestic, Non-Porous, A5000
5765-005EAFSA5FX	Stainless Enclosure, European, Non-porous, A5000

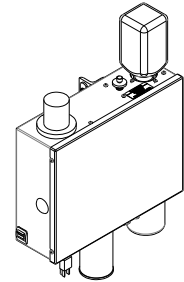

Marksman Duo XT Controller Assemblies

5765-010DNP1	Stainless Enclosure, Single Interface, NP, Domestic
5765-010ENP1	Stainless Enclosure, Single Interface, NP, European
5765-010DPS1	Stainless Enclosure, Single Interface, Domestic
5765-010EPS1	Stainless Enclosure, Single Interface, European

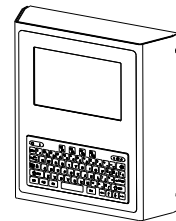

Porous Print Head Bracketry (ScanTrue II)

2464-550	Print Head Conveyor Mount Bracket
2464-561	X-Y Axis Linear Adjustment, tool-less Bracket
2464-562	Conveyor Mount/Roller Bracket for 768 Print Head
2464-563	Print Head Floor Mount Bracket Kit
2464-564	Conveyor Mount/Roller Bracket for 384 Print Head

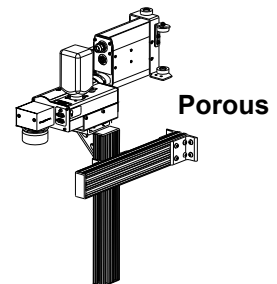

Non-Porous Print Head Bracketry (A5000)

5760-810	Roller/Retracting Bracket, IJ384 (Includes 5760-366)
2464-563	Print Head Floor Mounting Kit (Requires Single Print Head Kits)

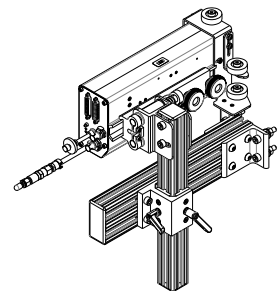

Controller Bracketry

5765-200	Controller Conveyor Mounting Bracket Kit
----------	--

Continued

Print Head Cables, Porous (ScanTrue II)	
2464182-010	Cable, Straight Thru, DB9, 10 Ft.
2464182-025	Cable, Straight Thru, DB9, 25 Ft.
2464182-050	Cable, Straight Thru, DB9, 50 Ft.
2465155-010	Cable Kit, Print Head, DB25, 10 Ft.
2465161-025	Cable Kit, Print Head, DB25, 25 Ft.
2464312	Cable, APS Photocell Network ("Y" Cable for Sharing Auxiliary Photocell)

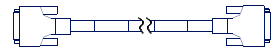

Print Head Cables, Non-Porous (A5000)	
5760-614-002	Print Head Cable Assembly, 2'
5760-614-010	Print Head Cable Assembly, 10'
5760-614-015	Print Head Cable Assembly, 15'
5760-614-025	Print Head Cable Assembly, 25'



Encoder	
5760-820-IJ	Encoder Assembly w/Mounting Bracket & 25' Cable
2464-182-010	Extension Cable, 10'
2464-182-025	Extension Cable, 25'

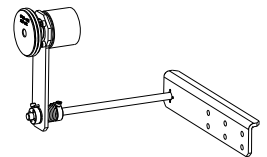

Beacon	
5760-345	Beacon, Remote, Pro Series IS

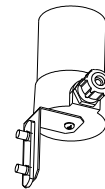

Photosensor (Porous)	
2465224	Photosensor, Pro Series, Porous (ScanTrue II)
2466525	Photosensor, Auxiliary, APS Controller

Photosensor (Non-Porous)	
5760-383	Photosensor, Diffuse Type & 20' Cable
5760-871	Photocell, Smart Cleaning System
2464-182-010	Extension Cable, 10'
2464-182-025	Extension Cable, 25'

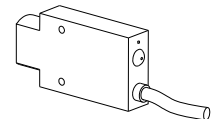

Automatic Air Knife (For use w/ Non-Porous System)	
5765-006	Air Knife, Double Sided System (Order with 5765-007)
5765-007FX	Air Knife, Single Sided System, Domestic
5765-007EFX	Air Knife, Single Sided System, European

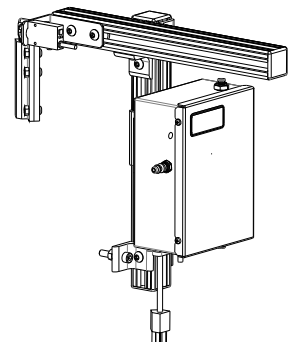

Section 4: Installation, Porous Print Heads

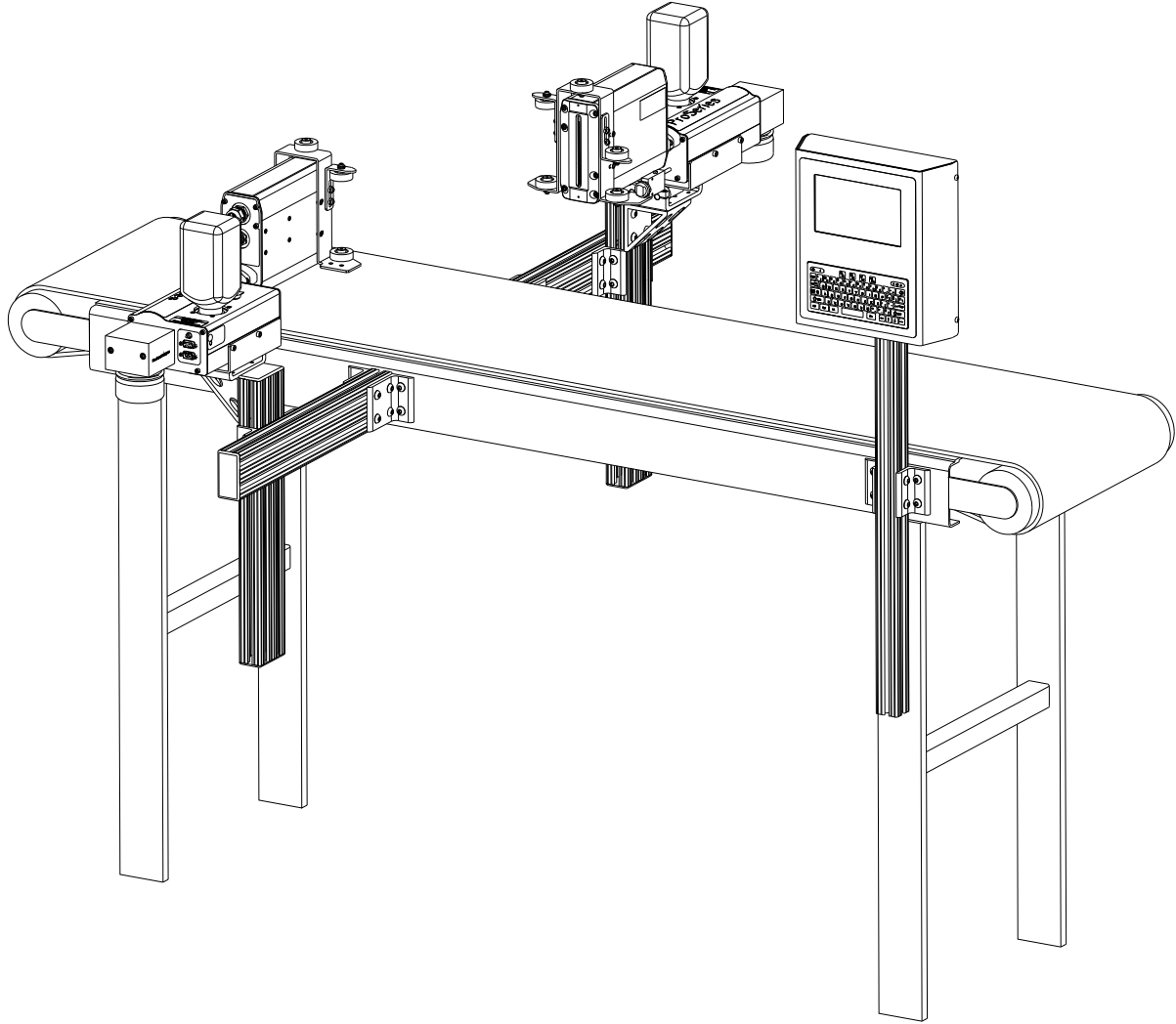

Electrical Cable Connections, Porous

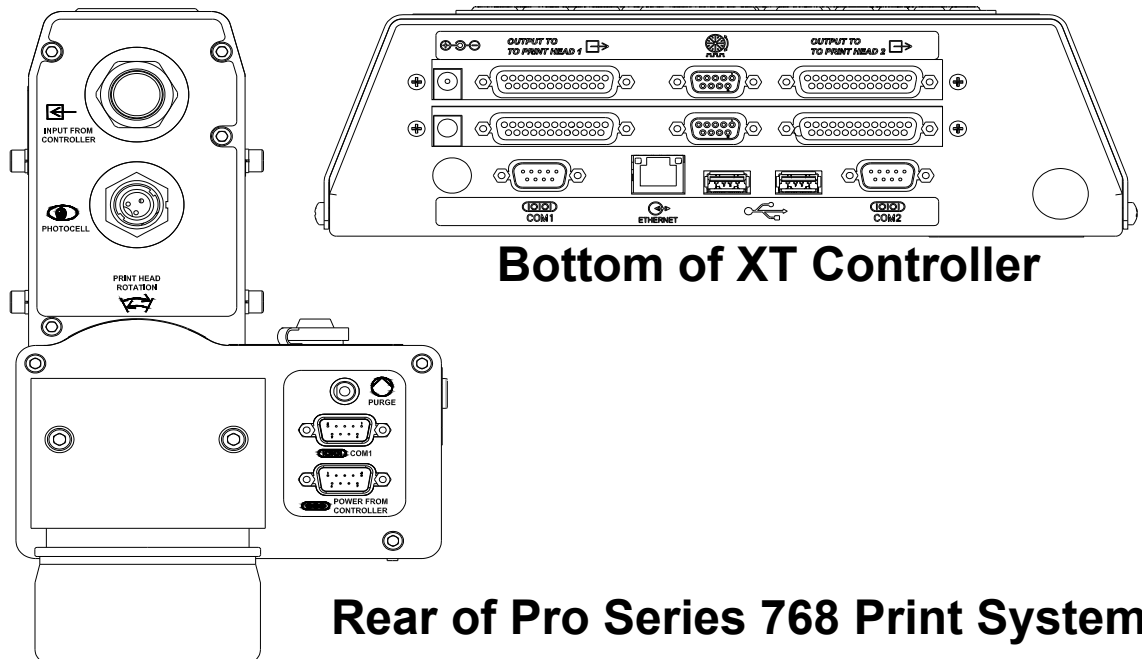
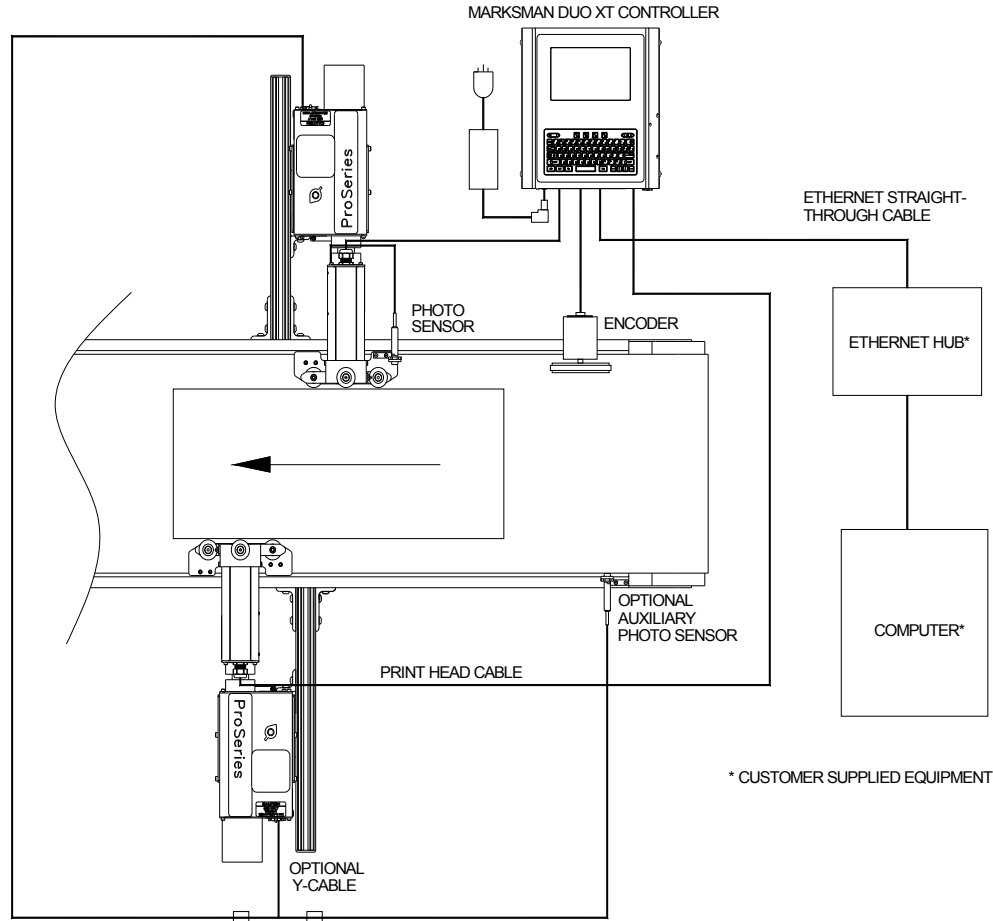

Installing Pro Series 384 and 768 Porous Print Heads

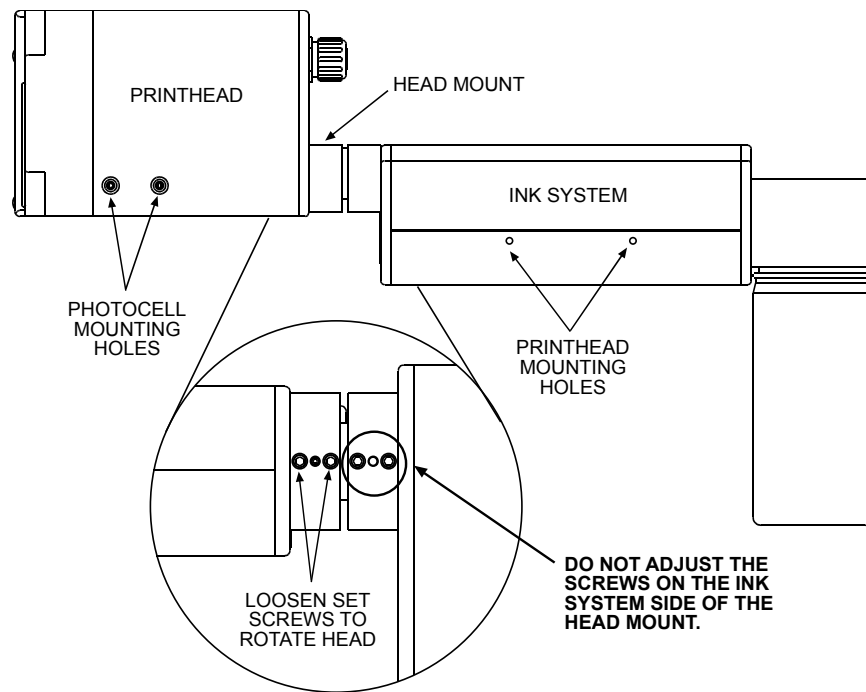

1. Remove packing materials and retain for possible future use.
2. Position the print head and install the screws that hold the print head to the print head bracketry.
3. Adjust bracketry so that the front of the print head is parallel to, and no more than 3mm (1/8") away from, the side of the carton as it passes in front of the print head.
4. Insure that conveyor guides are adjusted so that the cartons CANNOT hit the print-head.
5. Remove the Reservoir ship cap and install the ink bottle (insure the expiration date on the ink bottle has not yet occurred).
6. Open the vent cap and install a clean vent cap filter (FoxJet PN X40119-001).
7. If not installed, install an ink waste bottle (FoxJet PN X01240-002).
8. Remove the faceplate cover from the front of the print head (Save the faceplate cover and Reservoir ship cap for use when you remove the print head from the production line).
9. Unplug controller from power source.
10. Connect the print head cable to the controller.
11. Connect the photocell cable to the print head, if applicable.
12. Plug in the controller. The Print Heads will heat to temperature in approx. 5-10 min.

13. Take several lint-free Texwipes and press them against the front of the CP/OP to catch any ink.
14. Press the purge switch for three to four seconds to purge any air out of the system.
15. Spray the proper maintenance fluid (X31027-001 for ScanTrue II) on a dry wipe card or folded Texwipe.
16. Momentarily press the purge switch to initiate an automatic prime/purge cycle.
17. Wipe across the CP/OP with the wipe card or lint-free Texwipe to remove any excess ink and/or maintenance spray.
18. Run a print sample to ensure all the channels are printing and producing good print quality.

IF PRINT QUALITY IS ACCEPTABLE, PROCEED NO FURTHER.

If all channels are not printing properly, repeat steps 16 through 21. If the print head has not been in use for several months, it may take 30+ minutes for all channels to print.



NOTE: The print heads work on gravity and capillary ink feed, internal in the print head. The head must be mounted in a level position from front to back to prevent leakage.



CAUTION: Do not operate APS Print Heads with the Print Head Ship Cap installed! Operating a closed system can cause a siphoning effect which can drain the ink supply.



NOTE: If you place the Print Head Ship Cap on a hot print head and do not fasten it securely, the print head will weep ink until the head has cooled down.



NOTE: Ink may accumulate behind the ship cap during shipping.

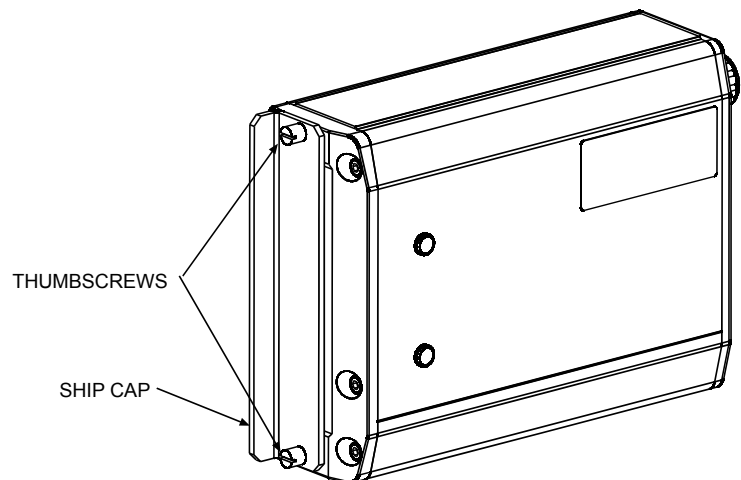

Installation

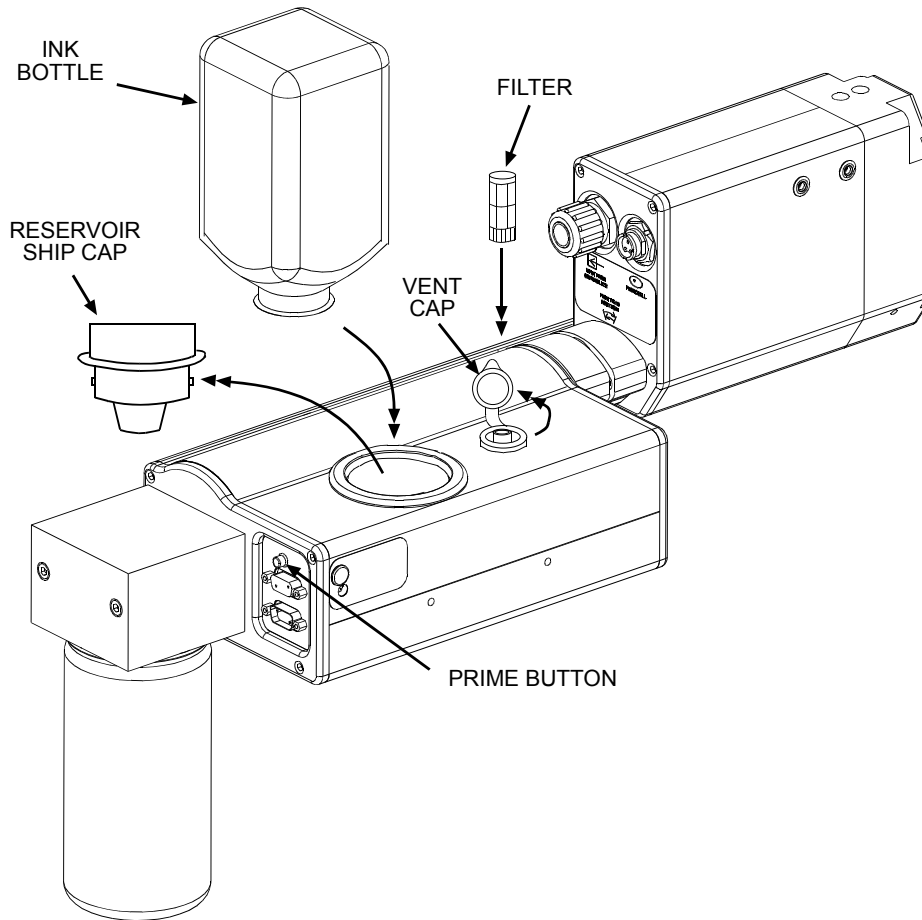

Priming the Print Heads

Manual Prime



NOTE: Place a wipe in front of the maintenance plate to catch excessive ink.

A manual prime can be accomplished by depressing the push-button switch on the rear of the ink system housing. Pressing and holding the button for longer than one second will start the pump for a manual prime. It will continue to run as long as the button is depressed, or up to five seconds. If additional priming is required, release and press the button again.

Pressing for less than 0.5 seconds will initiate a maintenance cycle. If the system has started a maintenance cycle and the button is pressed, the manual prime will not operate. (The Priming Sequence and the Vacuum Cycle are less than 10 seconds long.)

APS Cycle



The APS (Automatic Priming System) cycle is a means for re-priming channels in the head if some are missing. The APS system does this by using a priming pump to force ink out of the channels and a vacuum pump and collection bottle to collect the ink waste. The APS cycle can be manually started by momentarily pressing the prime button.

NOTE: The system may not print during an APS cycle or manual prime.

Print Head Control of APS

Print Head control of the APS (Automatic Priming System) cycle is accomplished by a programmed timing interval set by the user at the print head (each head, if more than one is used). It can be set to run as often as necessary. The default setting is once every 4 hours. The interval can be adjusted by means of a rotary switch mounted on the APS Controller PCB. (See the illustration below.)

0= No APS	UJII Heads										Graphics Heads					
Switch Setting	0	1	2	3	4	5	6	7	8	9	A	B	C	D	E	F
Interval (Hours)	0	2	4	6	8	10	12	14	16	18	1	2	4	6	8	12

Timing Interval Settings

The required time for the priming sequence is less than five seconds, with an additional 20 seconds for the vacuum cycle. Printing cannot occur during the priming sequence.

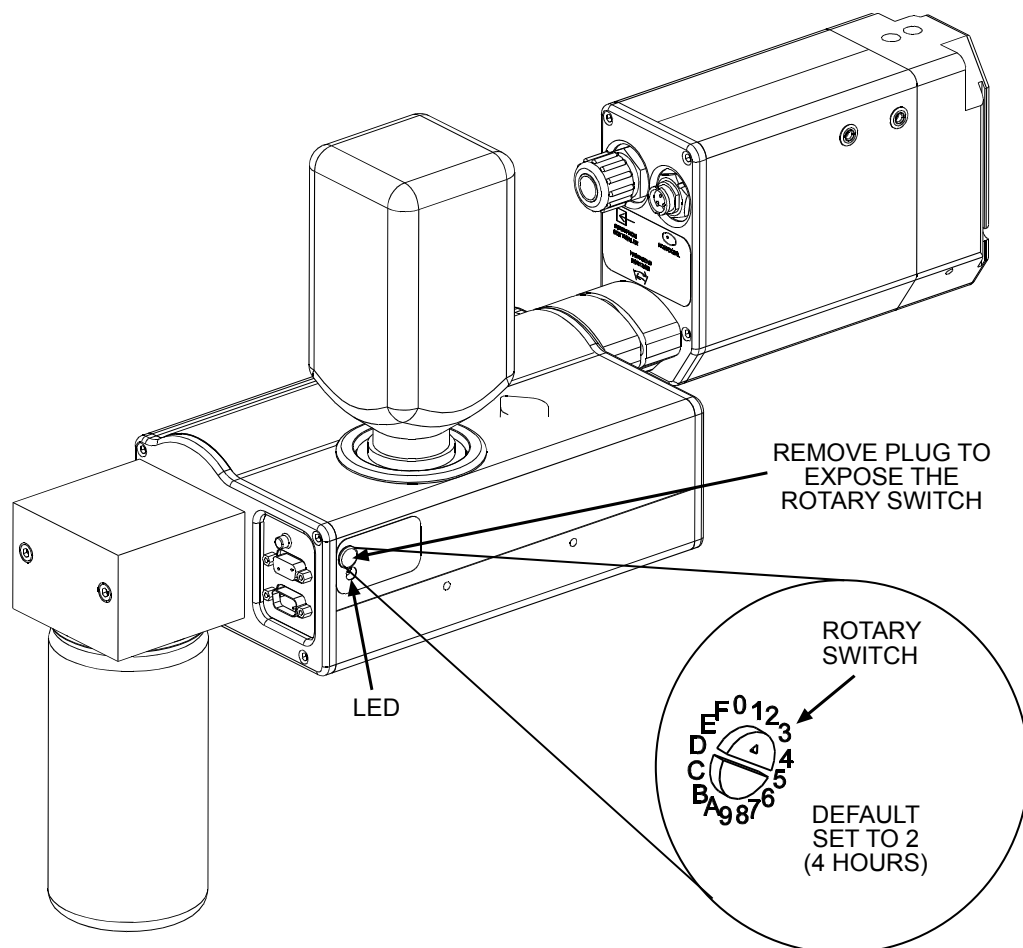

Auxiliary Photocell Input

An Auxiliary Photocell input is available to insure a print cycle is not missed during the automatic priming sequence. Connecting the Auxiliary Photocell will retard a prime sequence until there is enough time to complete the sequence without missing a print cycle. The default delay setting is three (3) seconds after the product passes the photocell. Multiple heads can share the Auxiliary Photocell by using the Photocell "Y" Cable. To change the default setting, perform the following steps:

1. Insure that the rotary switch is not in the "0" position.
2. Place a box in front of the photocell.
3. While the photocell is on, set the rotary switch to 0.
4. When the LED stays illuminated continuously, set the rotary switch to a new number (1 through F) representing the number of seconds (1 through 15) you want to delay. **Note:** "0" is not an available user setting.
5. Press and hold the Prime button until the LED starts flashing.
6. Release the Prime button.
7. Remove the box from in front of the photocell.
8. Set the rotary switch back to the desired hour setting.

Encoder

Mount the encoder such that the encoder wheel is in contact with the conveyor belt.

Adjust the spring collar to ensure that the encoder maintains stable contact with the conveyor.



CAUTION: Do not jam the encoder wheel against the surface of the conveyor. A radial force of over 40 lbs. will reduce the life of the bearings.

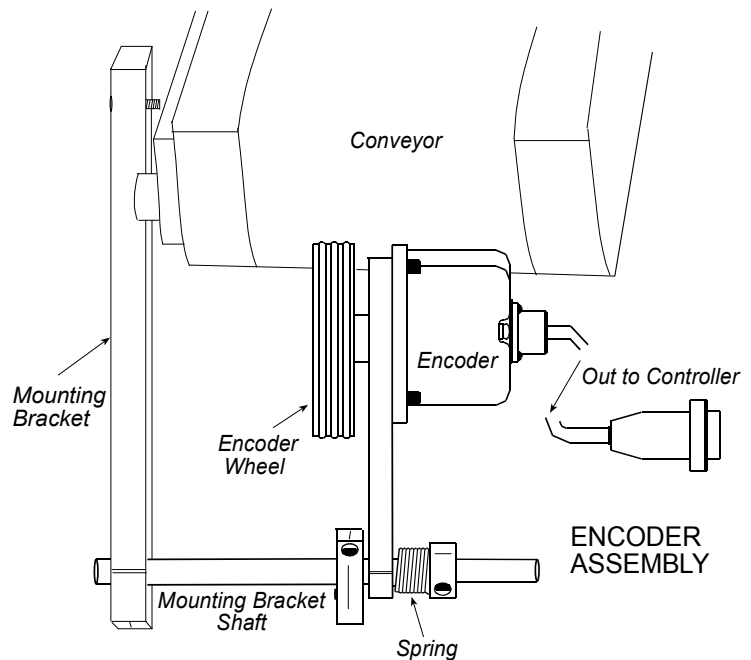

Section 5: Installation of Non-Porous Print Heads

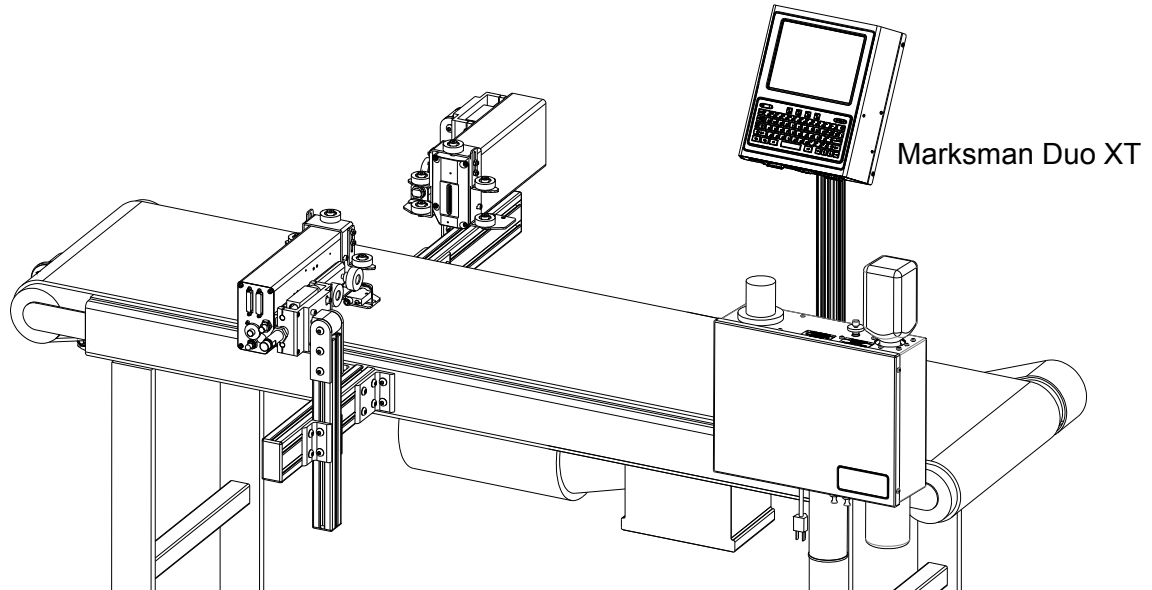

Non-Porous System Installation Overview

NOTE: The following steps give an overview of the procedure to properly install the Marksman Duo XT Non-Porous print system.

1. Carefully plan the mounting location of the equipment. Keep in mind bracketry hardware location and printer equipment size.
2. Remove equipment from packaging.
3. Assemble all bracketry to the floor, conveyor, or other bracketry per bracketry installation section.
4. Mount the Marksman Duo XT and Pro Series IS to their appropriate bracketry. Do not connect to power outlet.
5. Assemble the optional retracting and roller bracket to each print head, if applicable.
6. Mount the print head(s) to their appropriate bracketry and in the approximate location relative to the carton.
7. Mount the photosensor, optional bracketry, and optional encoder per procedure.
8. Make all appropriate electrical cable connections to the Marksman Duo XT. Do NOT connect the print head cables to the print heads.
9. Power the Controller and Ink Supply. Do NOT connect the print head cables to the print heads.
10. Install all plumbing lines, but do NOT insert quick-disconnect fittings into back of print heads.
11. Bleed all the ink lines per procedure.
12. Prime the print heads per procedure.
13. System is ready for first print.

Print Head Tilt

Maximum Print Head Tilt		
Print Head	Clockwise Tilt	Counterclockwise Tilt
NP384	5°	5°



NOTE: Tilt angles are given when looking at the rear of the print head. Front to rear tilt should be less than $\pm 1^\circ$.

Mounting the Print Trigger Photosensor (NP384)

1. Position the photosensor (5760-383) upstream from the first print head. The maximum placement distance is 27" from the photocell to the print head.

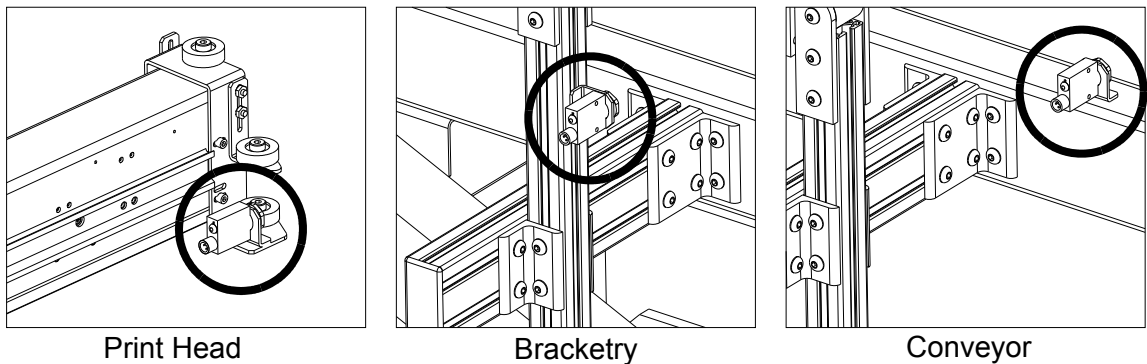

Mounting the Smart Cleaning System Photosensor (For 384 NP)

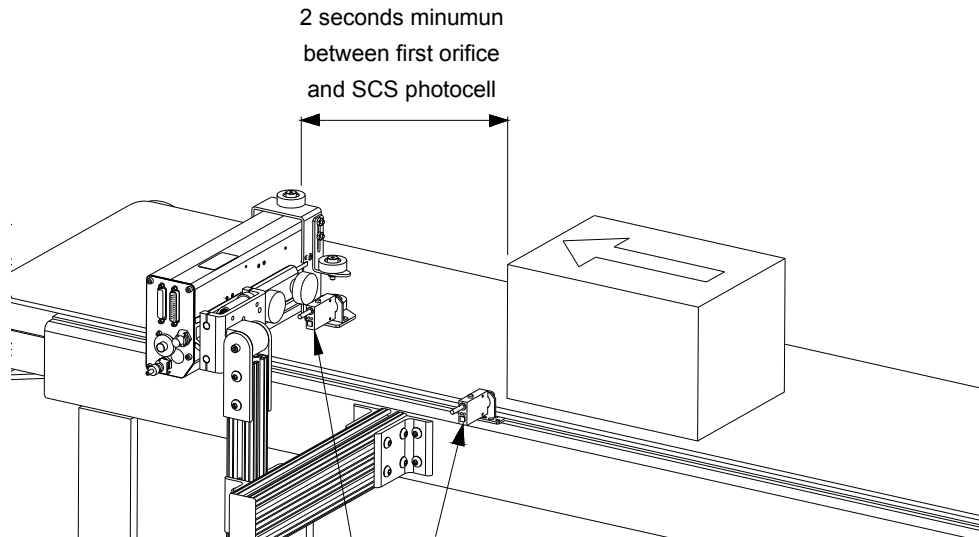

1. Mount the SCS photosensor upstream from the first print head such that it will trigger at least two seconds prior to print on the product.
2. Plug the SCS photosensor into the outlet port of the last print head in the daisy chain.

NOTE: The SCS photosensor does not trigger print; therefore, there are no configuration parameters for this device on the controller.

Electrical Cable Connections (384 NP)

1. Refer to the diagram below for typical electrical cable installation and routing.

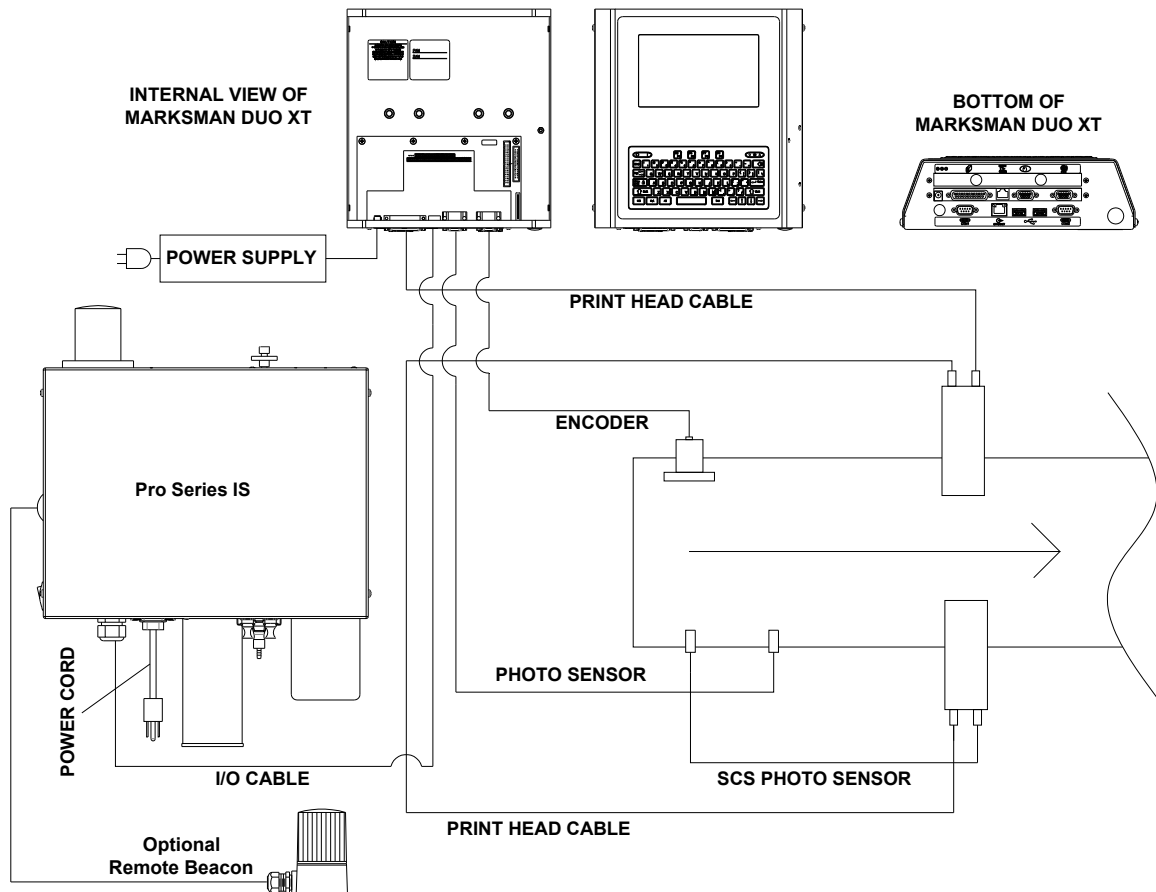

2. Connect the power cord(s), photosensor(s), and encoder(s) to their appropriate sockets.
3. Connect the I/O cable from the Pro Series IS to the RJ45 port in the Non-Porous Interface printed circuit board.



NOTE: To meet CE compliance, each power supply must have a separate, dedicated power line.



NOTE: Do not connect the Pro Series IS I/O cable to the mother board ethernet port.

4. Install the print head cable(s) to the appropriate interface board sockets.



NOTE: Do not connect these cables to the print heads. This will be completed during the bleeding procedure.

5. Plug both the Pro Series and Marksman Duo XT power supplies into appropriate outlets.
6. Toggle the Pro Series IS switch to the ON position.

Bottom of Marksman Duo XT

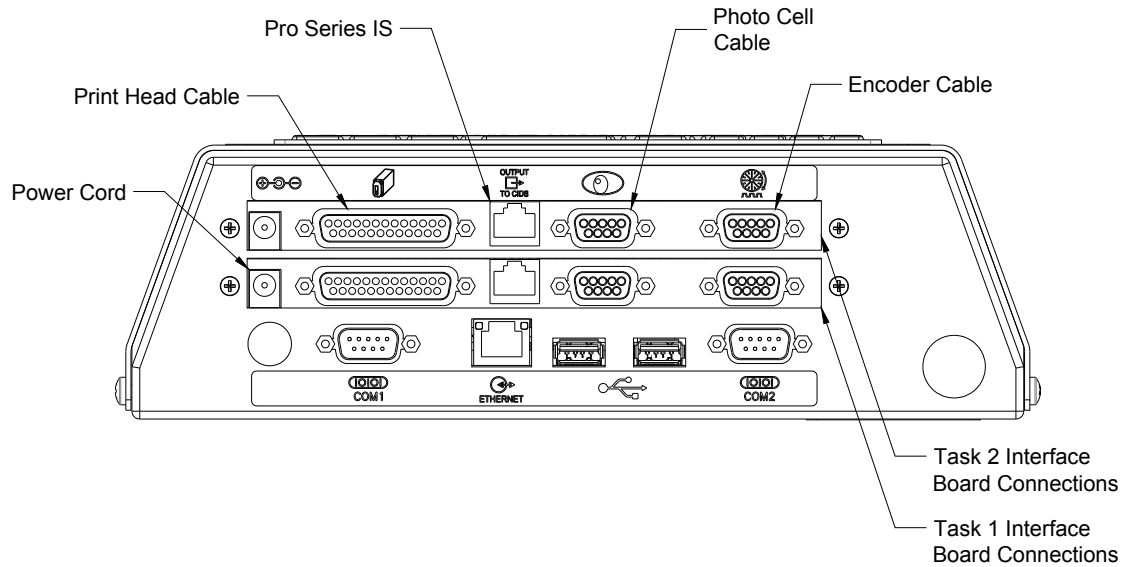

Plumbing the System (NP384)



NOTE: Do not attempt plumbing this system before all mechanical mounting is completed.



CAUTION: After mechanical mounting is completed for the Pro Series IS and the print heads, remove all vent caps and install the supplied filter.

CAUTION

 **REMOVE CAP**

 **INSTALL FILTER**



CAUTION: Do not connect print head cables. This step will be completed during the ink tubing line bleed procedure.

1. Refer to the following diagrams for typical print head plumbing connections.

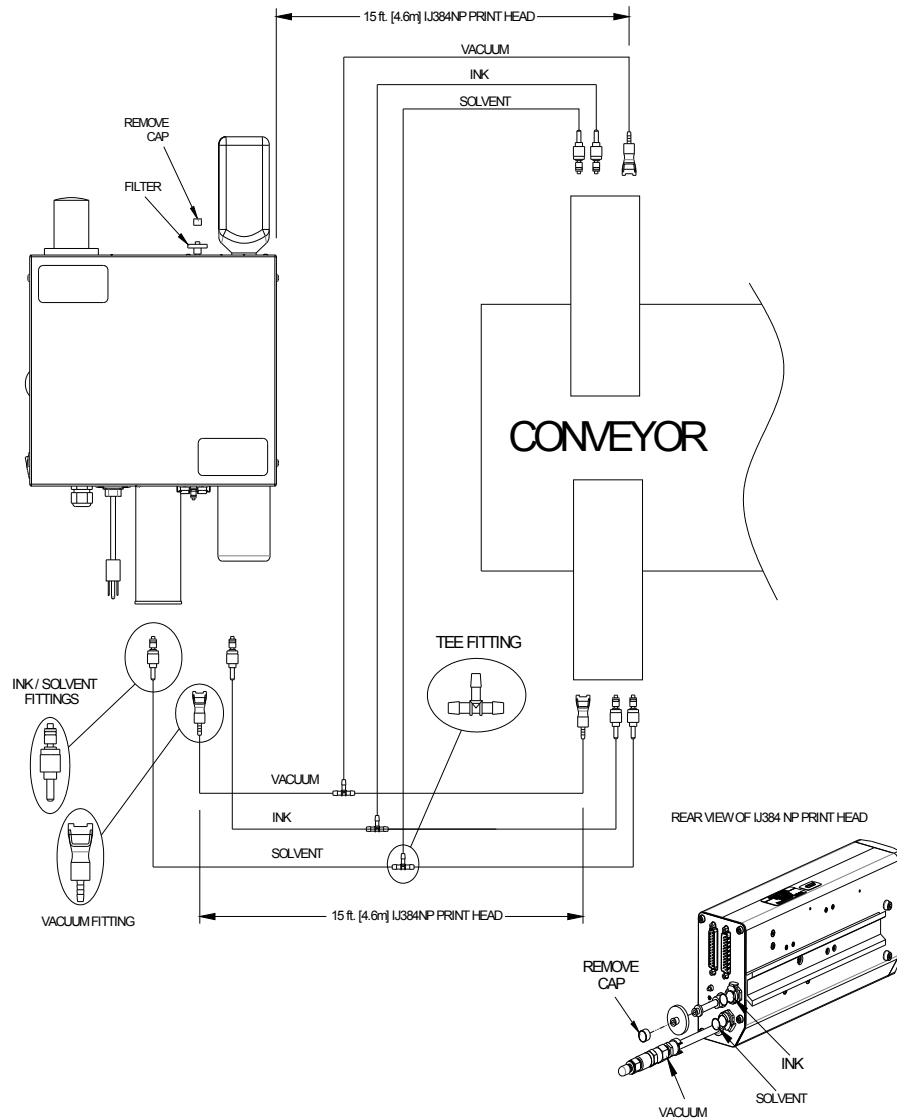

2. Cut all tubing to length as needed. Do not exceed the given tubing lengths specified in the diagrams for the particular application.



NOTE: Do not coil the vacuum tubing into multiple loops at either the Pro Series IS or the Print Heads as this inhibits waste ink flow.

3. Install all fittings into tubing per the supplied diagrams.

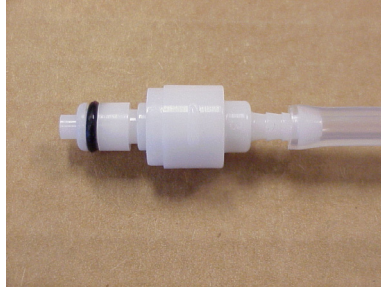

INCORRECT

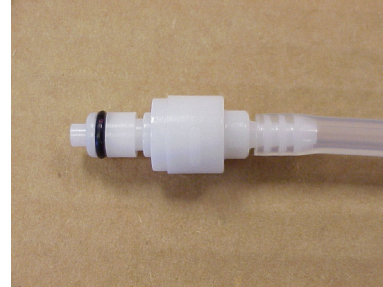

CORRECT

4. Insert quick-disconnect fittings into the Pro Series IS per the diagram.
5. Do not install the quick-disconnect fittings into the rear of each print head. This step will be completed during the ink tubing line bleed procedure.

Bleeding the Pro Seires IS Ink Tubing Lines (NP only)



CAUTION: Ensure all vent caps have been removed from the print head(s) and Pro Series IS.

CAUTION



REMOVE
CAP



INSTALL
FILTER

1. Ensure an ink bottle has been installed into the Pro Series IS reservoir.



NOTE: Never mix ink types because they are not miscible. irreversible internal damage will occur.

2. Ensure all tubing connections have been made, except for insertion of quick-disconnects into the rear of the print head.
3. Ensure all electrical cabling has been completed, except for plugging the print head cables into the back of the print heads; and both the Marksman Duo XT and Pro Series IS are turned on.
4. Start at the print head located nearest the Pro Series IS.
5. Insert the ink tubing line quick-disconnect into the vacuum tubing quick-disconnect at the first print head.

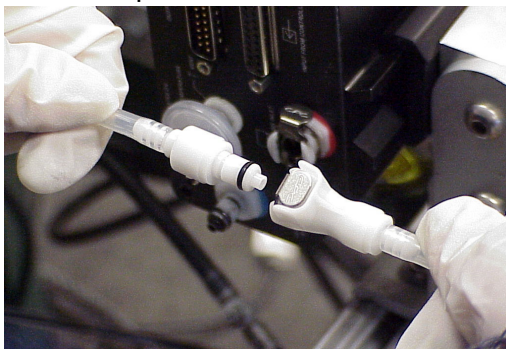

INK QUICK-
DISCONNECT

VACUUM QUICK-
DISCONNECT

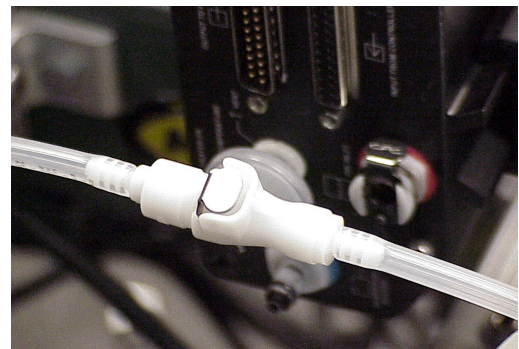

MATED

- Loosely hand-connect the print head cable from the appropriate port in the Marksman Duo XT to this print head. If the Pro Series IS pump turns on, wait for the ink to just pass through the quick-disconnect interface into the vacuum/waste line. After the ink has just pumped to the vacuum line, quickly pull the loosely connected print head cable. If the pump turns on, skip to Step 9.

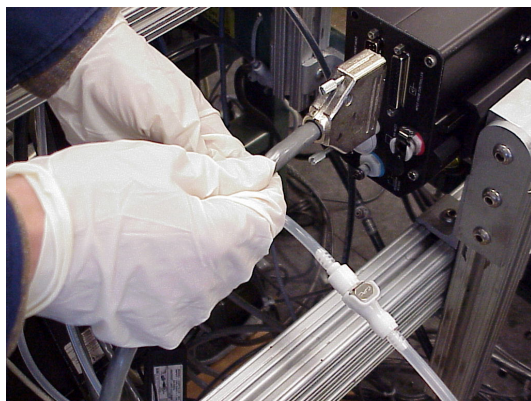

BEFORE PRINT HEAD CABLE IS CONNECTED AND INK TUBING IS BLED

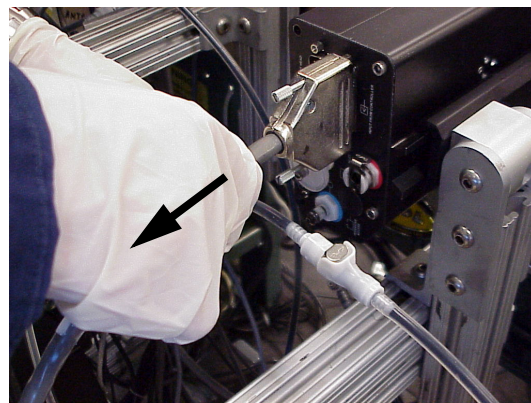

UNPLUG PRINT HEAD CABLE AFTER INK LINE IS BLED

- If the pump does not turn on, fasten the print head cable to the rear of this print head. Do not over-tighten as this will damage the jackscrew threads.

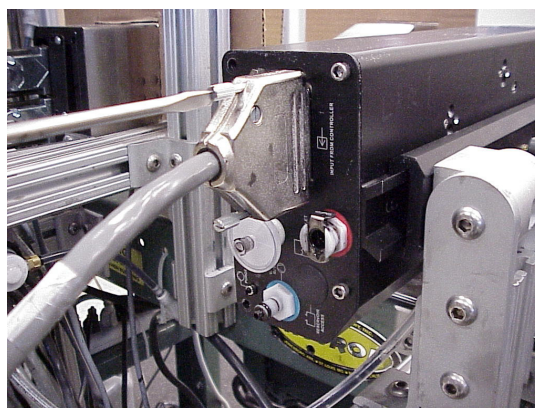

IF INK PUMP DOES NOT TURN ON, FASTEN PRINT HEAD CABLE

8. Press and hold the Purge button on the rear of this print head for approximately five seconds until the Pro Series IS ink pump turns on. After the ink has just pumped into the vacuum tubing line, quickly disconnect the ink and vacuum fittings.

PRESSING THE
PURGE BUTTON



AFTER INK LINE IS BLED

9. The solvent quick-disconnect fitting can be plugged into the vacuum fitting to bleed the solvent line. Be aware that the solvent will rapidly bleed through this line. Again quickly disconnect the two fittings.
10. Install the three quick-disconnect fittings into their appropriate ports in the rear of this print head.

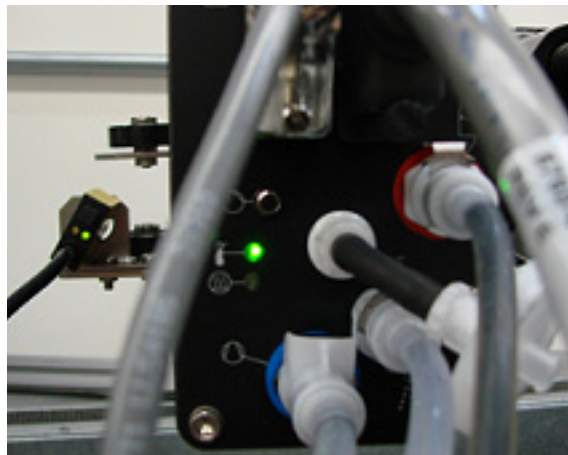

11. Repeat steps 6 through 9 for all remaining print heads, continuing to the next print head furthest from the Pro Series IS.

Max Tubing Height From Pro Series IS to Last Print Head.

Print Head Type	Number of Print Head(s)	Maximum Overall Tubing Length
384NP	1	40'
384NP	2	15'

Tubing limitations:

- Maximum vertical tube length (bottom of Pro Series IS to bottom of Highest Print head) = 20 ft (Ink pump limitation).
- Maximum height of Pro Series IS above print head(s) = 3ft (vacuum pump limitation).

Prohibited Conditions:

1. Do not run tubing up and over a conveyor at a height greater than 3'.

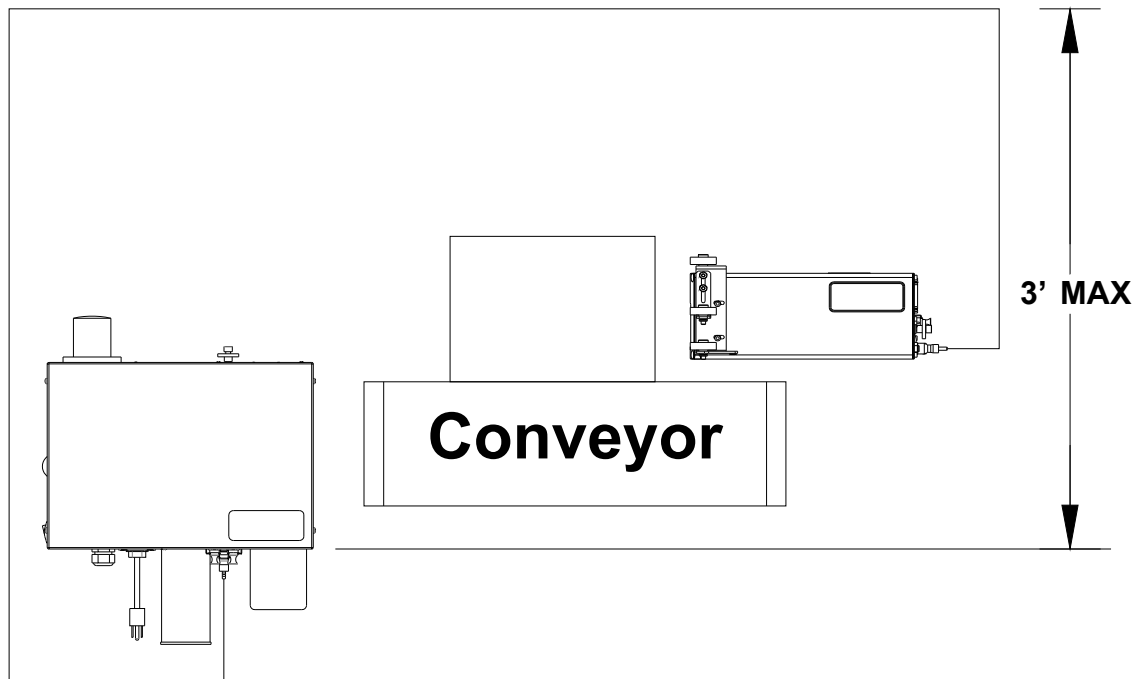

2. Do not coil excess tubing during installation (i.e. cut to length only).

Priming NP384 Print Heads Using the Auto-Prime and ACS Cycles



NOTE: The Print Station Configuration needs to be set up on the Marksman Duo XT Controller prior to priming the print heads. (Refer to the previous pages.)



CAUTION: Ensure the vent cap has been removed and the vent filter is installed.

CAUTION



1. Remove the print engine shipping cap.



LOOSEN TWO CAPTIVE THUMB SCREWS TO REMOVE SHIPPING COVER

2. Ensure all the print head cables are installed and the system power is on.
3. Ensure the ink tubing lines have been bled and the quick-disconnect fittings installed to their appropriate ports. Also, ensure the vacuum line is connected to the correct port.

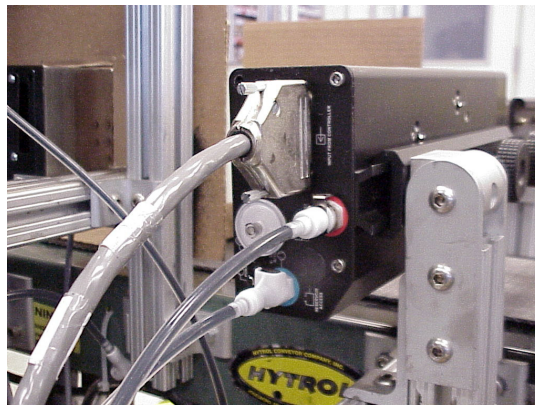

- Wait until the print head is at temperature.



NOTE: Print is disabled until the print head is fully heated. Wait until the "AT TEMPERATURE" LED is illuminated on the rear of the print head prior to any print sampling.

- Wipe the front of the print head with a lint-free cloth.
- Swipe a print sample by running a channel purge from the Marksman Duo XT.
 - On the Marksman Duo XT Home Screen, touch the **Print** menu button to open the Print Menu.

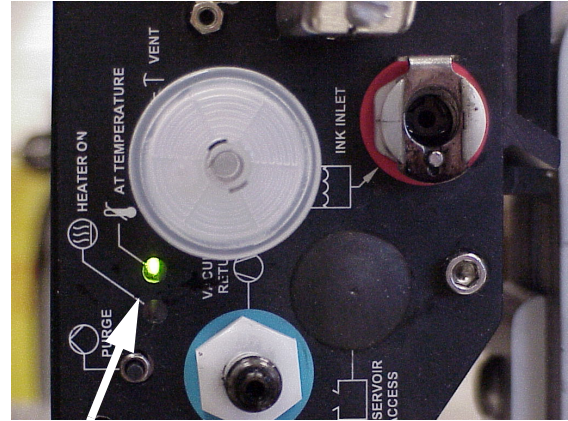

AT TEMPERATURE LIGHT IS ILLUMINATED

- Touch the **Purge** button to open the Purge Screen.
- Select the print head you want to channel purge by touching that print head.
- Touch the **Purge** button to channel purge the selected print head.

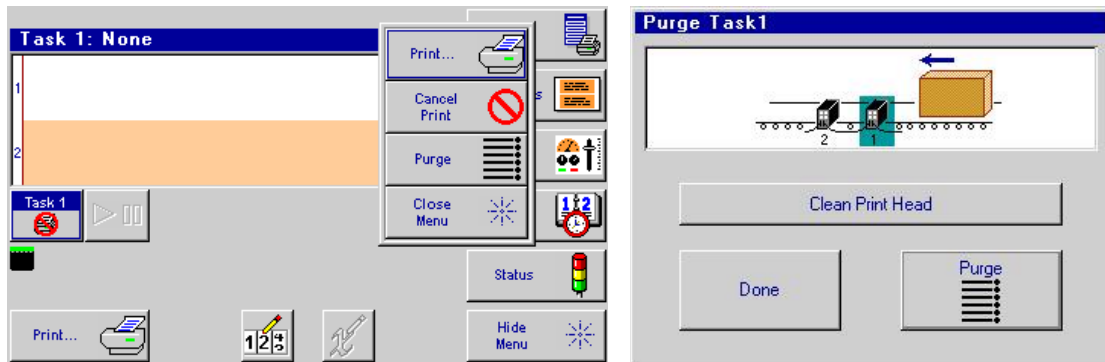

- Swipe a sheet of cardboard or other material across the front of the print head, at about the normal printing distance, as the head purges. The print head purges for three seconds each time the **Purge** button is touched.
- If channels are missing, hold the **Purge** button on the rear of the head for approximately .5 - 1 second. This will start an Automatic Cleaning System cycle (ACS).
 - If all channels are not printing, repeat steps 7 and 6 one more time.
 - If the print head is still missing channels, follow the procedure below. Otherwise, the print head is now ready for a print sample.
 - Hold an absorbent towel under the front of the print head to catch ink overflow.
 - Press and hold the PURGE button for five seconds (Auto Prime). The Pro Series IS beacon will flash and ink will flow continuously for two to four seconds. The vacuum pump will turn on and assist ink removal; however, overflow is likely.
 - If there are any air bubbles during ink flow, run another Auto Prime.
 - Repeat step 12 until the ink flows clear of air (typically one to two Auto Prime cycles).
 - Wipe off the excess ink from the front of the print head with a lint-free cloth.
 - If any channels are not printing after all air bubbles are purged, allow the print head to remain heated.
 - Occasionally, swipe a print sample until all channels are printing.

Section 6: Getting Started

Keypad

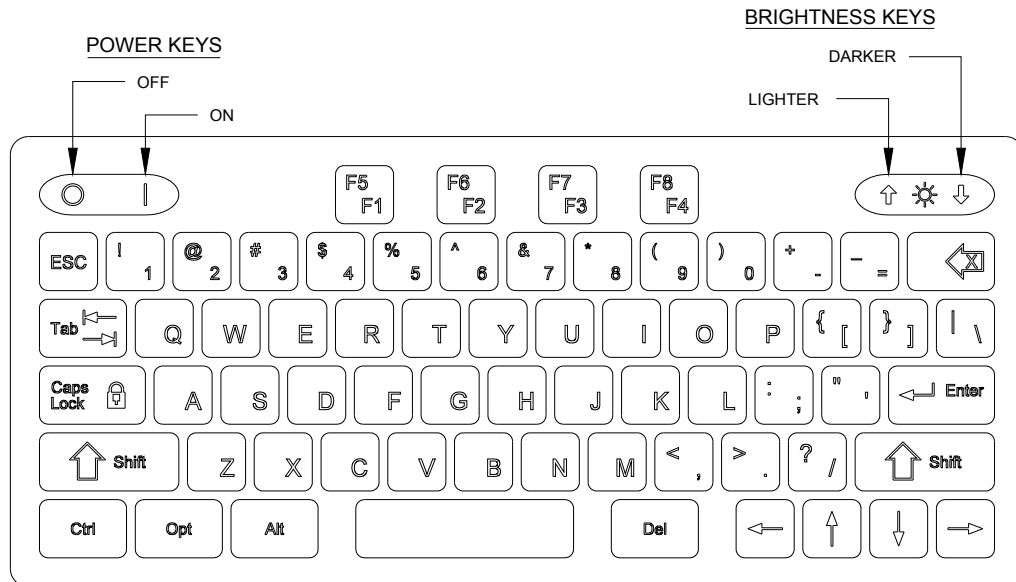

Turning the Controller On

Press the | key to turn the controller on. Press the O key to turn it off.



CAUTION: If the system is in the Print mode when it is turned off, it will resume printing when it is turned back on. Anything that is in front of the print heads when printing resumes may get ink on it.



CAUTION: Turning the system off doesn't remove power from the unit. The power must be disconnected from the system before connecting or disconnecting heads.

Home Screen

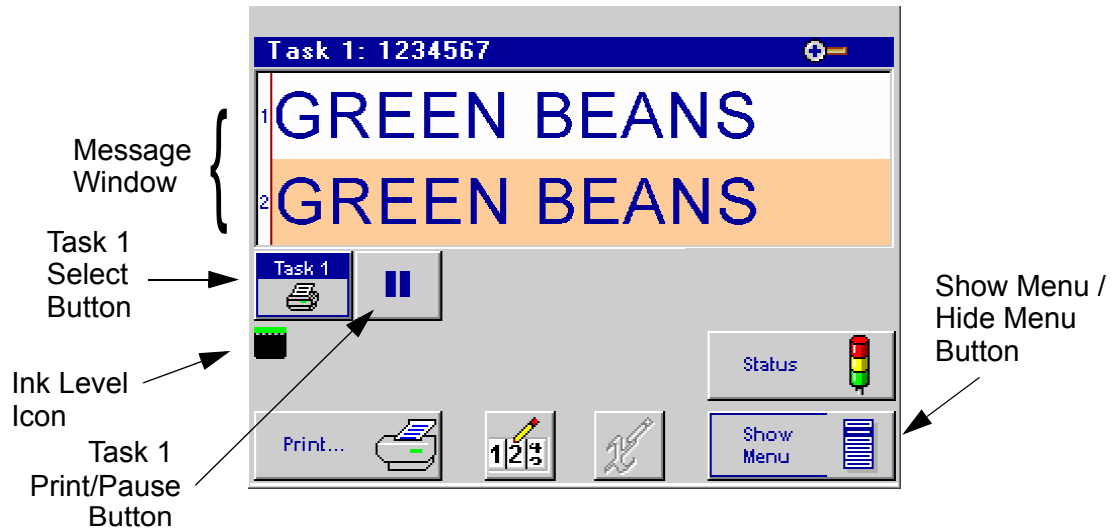

Message Window

The Message Window displays the current print message as it will look the next time it is printed. If no message is loaded to print, the window is empty. The message window is updated approximately every seven seconds, so it likely will not show each print.

Long print messages that do not fit completely within the Message Window can be viewed by using the **F1** and **F2** keys to scroll the message left and right, respectively.

The appearance of the message window reflects the system setup. Each numbered white or beige bar represents a print head in the daisy chain. The text on a bar is the text printed by that print head. If printing on a single side of the product, only one window is shown. Two windows are displayed when utilizing two-sided printing, with the top window always being side 1 or the side closest to the controller.

The window's header displays which task the print message is being printed on and the file name of the message being printed. If no message is loaded to print, "**None**" is displayed.



Ink Level Icon

- Green = Ink Level OK
- Yellow = Low Ink
- Red = Out of Ink

Task 1 Button

Touch the Task 1 button to display the Task 1 message in the Message Window.

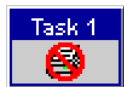

The task is either paused or no print message is loaded to print.

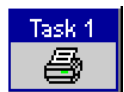

If the red circle and slash is not displayed, the task is printing.

Print/Pause Button



The Print/Pause button looks like this when the task is printing. Touch the button to pause printing.



The Print/Pause button looks like this when the task is paused. Touch the button to resume printing.



The Print/Pause button looks like this when no message is loaded for print.

Crosshairs Pointer:

The crosshairs pointer indicates where a new data field is placed. Use the keypad keys listed below to move the crosshairs pointer around the Edit Window.

Touching the screen inside the Edit Window can also move the crosshairs pointer.

The color of the crosshairs pointer changes from black to red when it moves over a data field.

Direction	384 & 768 Distance	Press keypad key
up/down	3 dot row	up/down arrow
up/down	Height of current font	Shift + up/down arrow
up/down	1 dot row	Alt + up/down arrow
down	Height of current font	Enter (when no fields are highlighted and the crosshairs pointer is black)
left/right	6 print columns	left/right arrow
left/right	54 print columns	Shift + left/right arrow
left/right	1500 print columns	Ctrl + left/right arrow
left	6 print columns	Backspace/Delete (when no fields are highlighted)
left	54 print columns	Shift + Backspace/Delete (when no fields are highlighted)
left	1500 print columns	Ctrl + Backspace/Delete (when no fields are highlighted)
right	6 print columns	Space Bar (when no fields are highlighted)
right	54 print columns	Shift + Space Bar (when no fields are highlighted)
right	1500 print columns	Ctrl + Space Bar (when no fields are highlighted)

Next Field Button:

Touch the **Next Field** button to highlight or select the data fields in the order in which they were added to the print message. Once a field is selected, it can be moved around the Edit Window or its contents can be edited.

Fields cannot be moved over other fields, they must be moved around them. When a field is positioned appropriately, press **Enter** to de-select it.

A field can also be selected by moving the crosshairs pointer over it (as indicated by the crosshairs pointer turning red) and pressing **Enter**, or by touching the field directly.

Direction	384 & 768 Distance	Press keypad key
up/down	1 dot row	up/down arrow
up/down	9 dot rows	Shift + up/down arrow
up/down	1 dot row	Alt + up/down arrow
left/right	6 print columns	left/right arrow
left/right	54 print columns	Shift + left/right arrow

Current Position Indicator:

The X position is given in inches from the left edge of the active print area. The Y position is given in dot rows from the top of the active print area.

Side 1/Side 2 Buttons:

Touch the **Side 1** or **Side 2** button to display side 1 or side 2 of the print message. The button that appears pressed or pushed indicates which side is currently displayed.

Section 7: Setup Functions

Tasks

A task consists of all operations associated with a single interface board.

Configuring the Print Station

Print Head Setup Screen

On the **Home Screen**, touch **Show Menu**, **Control Panels**, then **System Setup**. Screen prompts guide the user through the step by step print head setup procedure. To begin the print head setup procedure, touch the **Redo Print Head Setup** button.

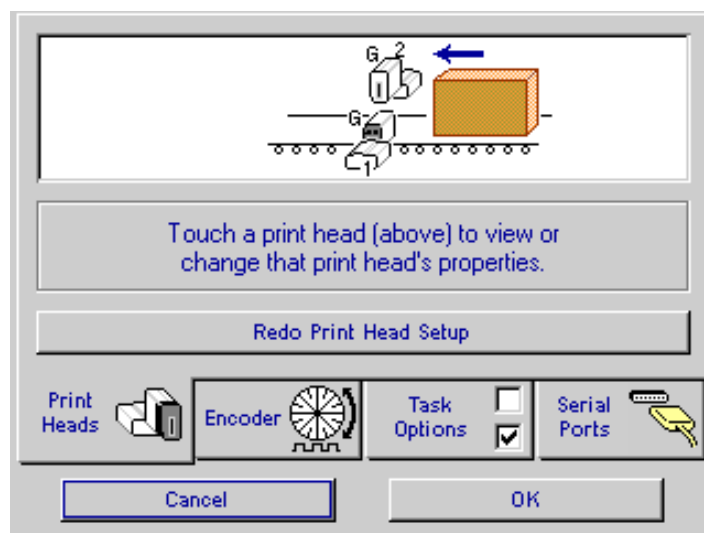

Setting Head 1 and Head 2



NOTE: The first print head should be the top print head in the system, as this one will be printing the top line of data.

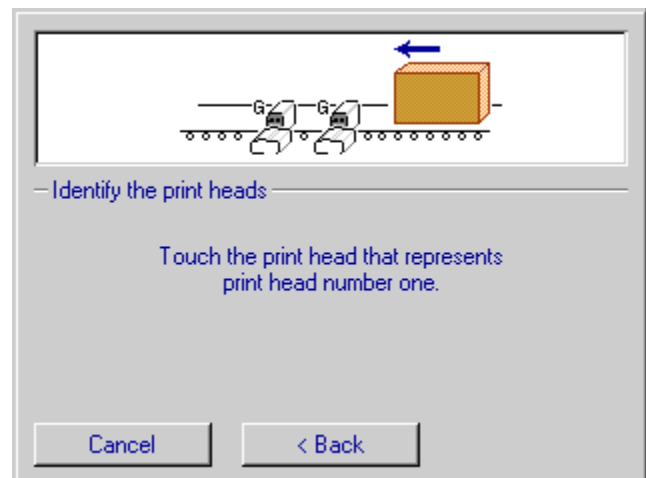

Defining Print Head Properties

The final step in print head configuration is defining the properties of the individual print heads.

- **Print head type and size:**

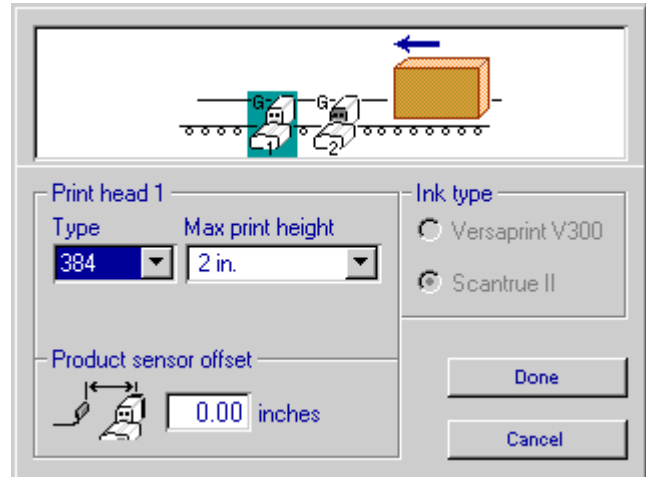
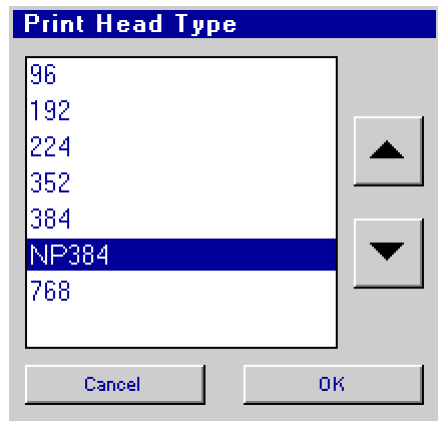

- **Product sensor offset:** Enter the distance between the photosensor and the print head, in inches. This may need to be fine-tuned after print setup.



The maximum sensor offset for the 384 and 768 Print Heads is 27".

- **Ink Type** indicates the type of ink used for the selected print head.

After the last print head is defined, touch the **Done** button.

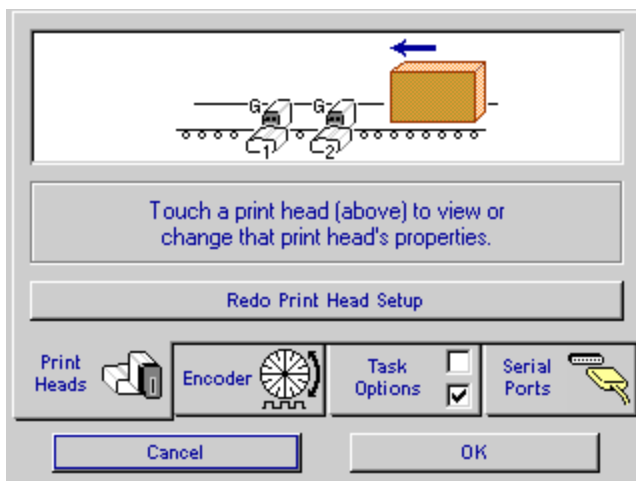

Touch any print head on the display to review or change the properties for that head. Touch **OK** to return to the **Home Screen**.

Encoder Setup

Touch the **Encoder** tab at the bottom of the **System Setup** screen.

A gray box surrounds the current encoder selection.

Use an external encoder if the line speed varies or the line makes frequent starts and stops. External encoder resolution is fixed at 300 ppi (pulses per inch).

Use the internal timer if the line speed is constant, with a minimum of starts and stops.

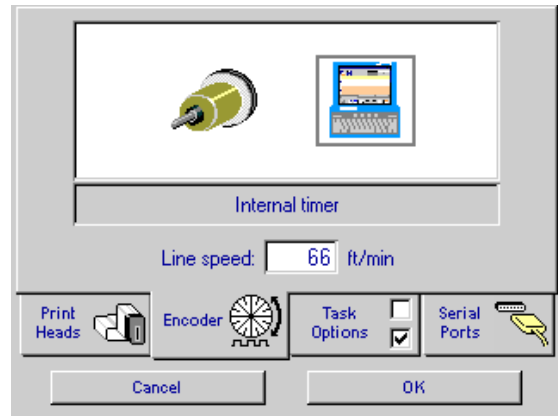

Task Options

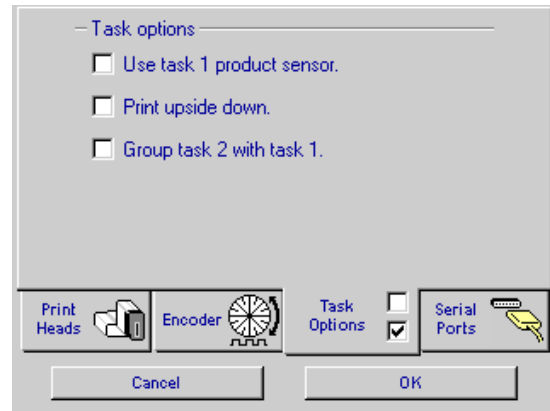
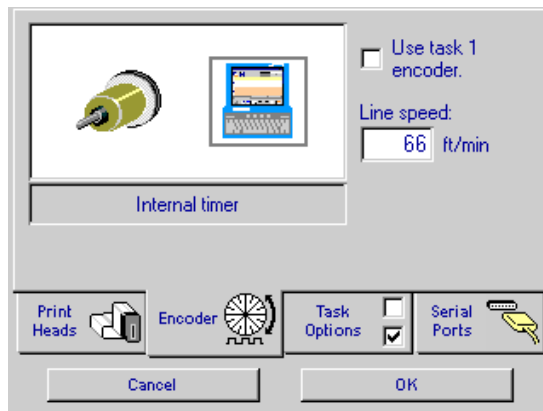

The Marksman Duo XT ships standard with one or two interface boards. Print Heads connected to the second interface board comprise a separate print station, which is referred to as task 2.

Sharing and Encoder and/or Photosensor

In many cases, it is possible to use the same encoder and/or photosensor to control both tasks. This is done by connecting the cables to the first interface board and directing Task 2 to share these with Task 1.

Group Setup

The Marksman Duo XT can be setup to create and manage messages for both Task 1 and Task 2 as a single “group” message. this allows for single message editing for a two task controller with multiple heads on each task. The group function is only utilized for dual task controllers. The system must be in group mode to create, edit, and print a group message.

Serial Port Setup

NOTE: The following settings are fixed on the Duo XT and cannot be changed. Any device connected to a Duo XT serial port must be configured to match these settings.

- Data Bits: 8
- Stop Bits: 1
- Parity: None
- Flow Control: None

To set up the COM1 and COM2 serial ports:

1. On the **Home Screen**, touch the **Control Panels** button to open the Control Panels menu.
2. Touch the **System Setup** button on the Control Panels menu to open the System Setup screen
3. Touch the **Serial Ports** tab on the System Setup screen to display the Serial Ports page.

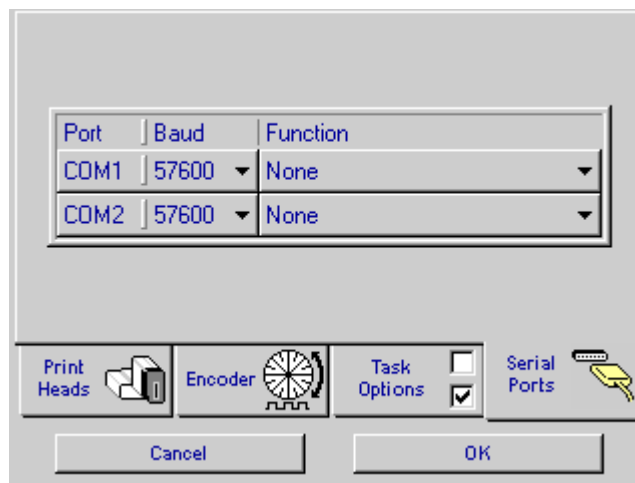

4. Touch a COM port **Function** button to open a list box showing the functions available for the related port. Select the desired function and touch the **OK** button.

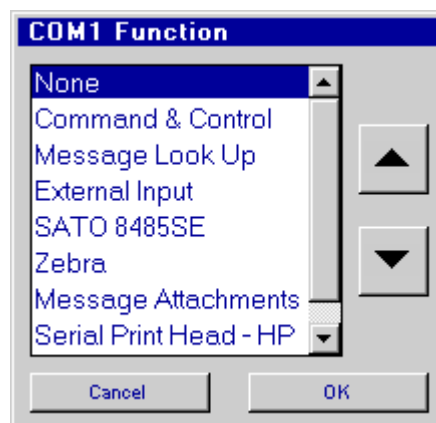

Serial port functions:

- **Command & Control:** This function allows external devices limited control of the Duo XT controller. Files may be uploaded, messages printed, and various controller settings may be modified. For complete details see the Software Interface Document, P/N 5760-113.
- **Message Look Up:** This function allows external devices to select a message to print from those stored in the controller's memory. Message look up is COM port/task specific. That is, to print a message on Task 1 send the message name to COM1; to print a message on Task 2 send the message name to COM2. A bar code scanner is most commonly used for message look up, but other devices, such as a PC or PLC, may also be used.

NOTE: The message name received at the serial port must exactly match the name of a print message stored in the controller. If no match to the message name received is found the current print message is cancelled and printing stops.

- **External Input:** Use the External Input function to change what is printed in a variable field or bar code field while the message containing the field is printing. The serial port the variable field or bar code accepts data from is specified when the message is created. See *"Adding a Variable Field" on page 43*, and *"Adding a Bar Code" on page 44*.
- **Sato 8485SE & Zebra:** Useful in dual technology applications (coding and labeling), these functions simplify product changeover by allowing the Duo XT print message and the label printed by a label applicator with Sato 8485SE or Zebra print engines to be changed in a single operation. The label format file is attached to the print message when the message is created. When the message is later selected to print the file is sent to a label applicator attached to the serial port. See *"Section 8: Message Functions" on page 38* for details.
- **Message Attachments:** A message attachment is a file or user defined text string that is appended to a print message when the message is created. The attached file or text string is then sent out one of the controller's serial ports when that message is selected to print. Message attachments can be used to control devices external to the Duo XT (the Sato 8485SE and Zebra functions described above use message attachments). See *"Section 8: Message Functions" on page 38* for details.
- **Serial Print Head-HP:** Select the Serial Print Head function to configure the Duo XT to drive SoloSeries print heads. Each serial port can drive up to eight SoloSeries45 or four SoloSeries90 print heads. Serial print heads are automatically assigned to the first available task. For complete details of the Thermal Jet print heads see the *Thermal Jet Ink Jet System Operations Manual*, P/N 5780-329.

5. Touch a COM port **Port|Baud** button to open a Serial Port Setup dialog box for the related port.

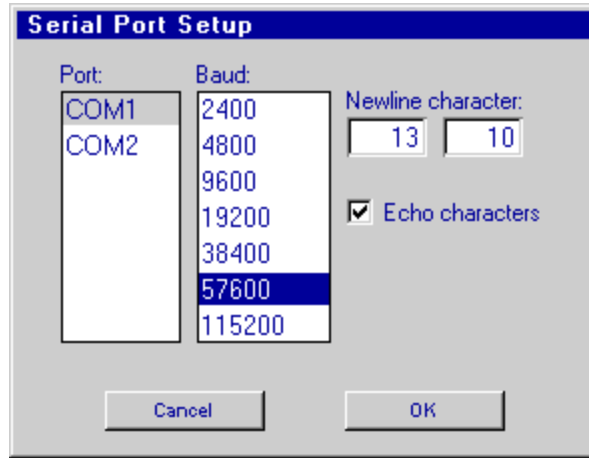

Select the port, if applicable, and the port's baud rate. Most users can touch the **OK** button at this point; advanced users may want to change the newline character, or disable the echoing of characters received by the Duo XT.

Newline character: A carriage return/line feed (CRLF) is the default newline character for the Duo XT. If your equipment uses a different newline character enter it in the **Newline character** boxes as decimal numbers (e.g. CR = 13, LF = 10). If your equipment uses a single character instead of a two-character sequence, enter it in the right hand box and clear the left hand box. If both boxes are left blank the newline character will be set to CRLF.

Echo characters: The default setting is "checked". If your equipment does not expect the Duo XT to echo all received characters uncheck the **Echo characters** check box.



NOTE: If using **Message Attachments** on one Duo XT to control **Message Look Up** on a second Duo XT, **Echo characters** on the second Duo XT should be turned off (not checked).

Network Setup

If the system is being used in a network application, the factory programmed network settings may need to be changed. If the network application is not being utilized, this section can be skipped.

To display the Network Setup screen:

1. On the **Home Screen**, touch the **Control Panels** button.
2. Touch the **Network** button on the Control Panels Menu.

The controls on the Map Network Device page of the Network Setup Screen apply only if the system is running on a network controlled by a PC using the network software.

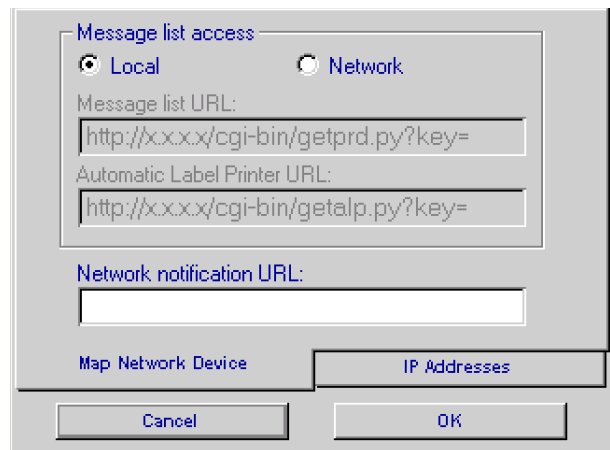

Message List Access

The **Message list access** controls determine whether the print messages listed in the Print...Message Selection box are local (stored in the system's internal memory) or on the network. Touch the radio button appropriate to the application.

If **Network** is chosen, the **Network message list URL** and **Automatic Label Printer URL** text entry boxes become active. Enter the address where the system will find the network-stored messages and, if applicable, enter the address where the system will find files for the Automatic Label Printer. For more details, contact Technical Support.

Network Notification URL

If this text entry box is filled in, the controller will send out a packet on the network to the host specified. This packet will be sent at controller boot up and at each photocell trigger input. For more details, contact Technical Support.

Setting IP Addresses

Touch the **IP Addresses** tab to display the IP Addresses page.

An IP address has four segments. The value of each segment may be from 0 to 255.

The 1st Ink System IP address and the 2nd Ink System IP address are not used in the Marksman Duo XT controller.

Touch the **OK** button to save the changes and return to the Home Screen.

Ask your network administrator for appropriate IP settings and enter them below.

Controller	10 . 1 . 2 . 3
1st Ink System	10 . 1 . 2 . 2
2nd Ink System	0 . 0 . 0 . 0
Subnet Mask	255 . 255 . 255 . 0
Gateway	0 . 0 . 0 . 0

Map Network Device IP Addresses

Cancel OK

(Default IP Addresses)

Defining User Codes

User Codes are user-defined time and date codes for printing hour, minute, date, month, and week of the year information. Each code may be up to four characters long.

To display the Edit User Codes screen:

1. On the **Home Screen**, touch **Control Panels**.
2. Touch **User Codes**.

Component	Hour	Code
Hour	00	A
Minute	01	B
Day	02	C
Date	03	D
Week	04	E
Month	05	F
Year	06	G
	07	H

Restore Defaults Cancel Apply OK

The default codes are:

- Hours: 24 single letter codes A through Z, except the letters I and O (which may be confused with the numbers 1 and 0).
- Minutes: 60 two-letter codes AA through AZ, then BA through BZ, then CA through CM. The letters I and O are not used.
- Date: 31 two letter codes AA through AZ, then BA through BG. The letters I and O are not used.
- Week: 53 two-letter codes AA through AZ, then BA through BZ, then CA through CE. The letters I and O are not used.
- Month: 12 three-letter abbreviations, JAN, FEB, MAR, APR, MAY, JUN, JUL, AUG, SEP, OCT, NOV, and DEC.
- Year: 99 two-letter codes AA through AZ, then BA through BZ, then CA through CZ, then DA through DZ, then EA through ED. The letters I and O are not used.

When defining user codes, avoid extremes in the number of characters for different codes within a component. For example, avoid defining hour 00 as 'A' and hour 03 as 'AAAA.' If print codes like 'A' and 'AAAA' must be printed, be sure to reserve enough room in the print messages so that the longest codes don't overlap adjacent fields when they print.

Time & Date Screens

Touch the **Time & Date** button on the **Home Screen**. The **Time** screen will appear with tabs along the bottom to set Time, Date, Rollover Time, and Shifts.

The Time Screen

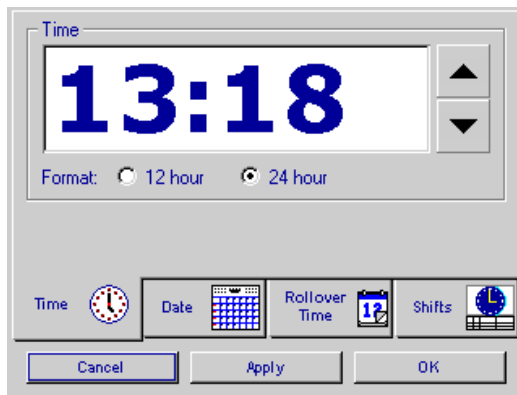

The Date Screen

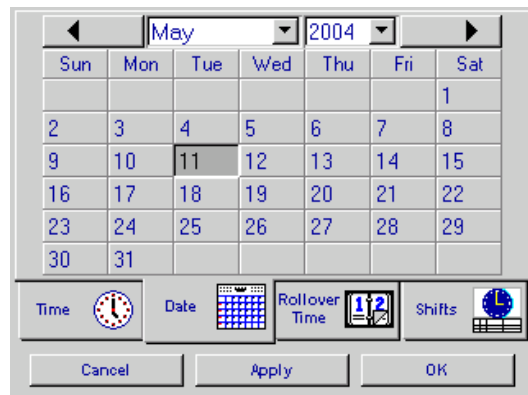

The Rollover Time Screen



NOTE: Rollover times between 12:00 PM and 11:59 PM will change the day/date of autocodes before midnight; rollover times between 12:00 AM and 11:59 AM will change the day/date of autocodes on or after midnight.

The default rollover time is 12:00 AM (00:00 on the 24-hour clock.)

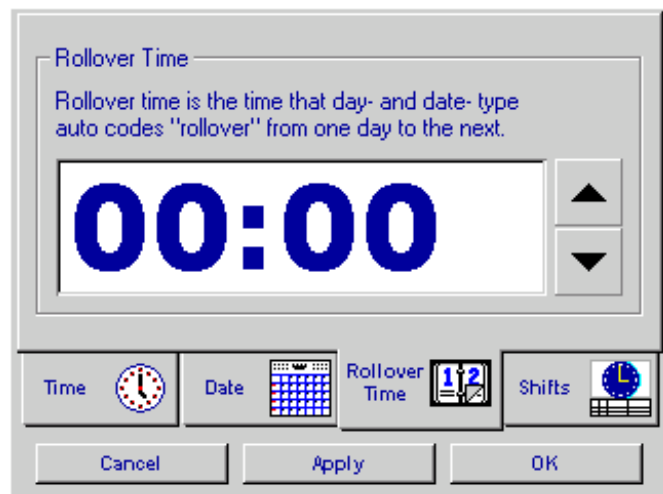

Shifts

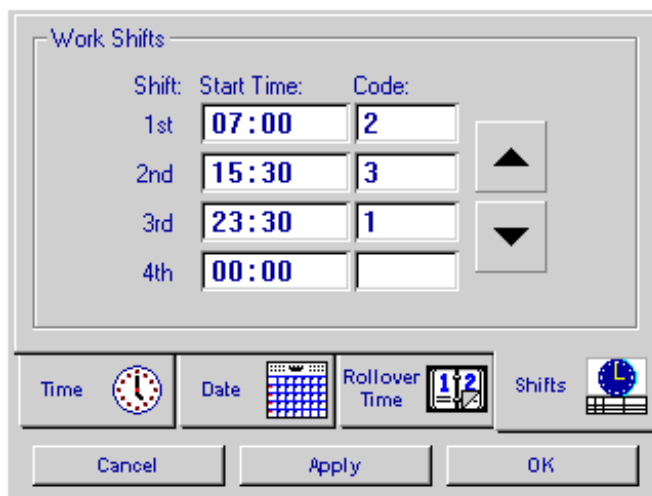

Section 8: Message Functions

Creating a Print Message

Step 1: On the Home Screen, touch the Messages button.

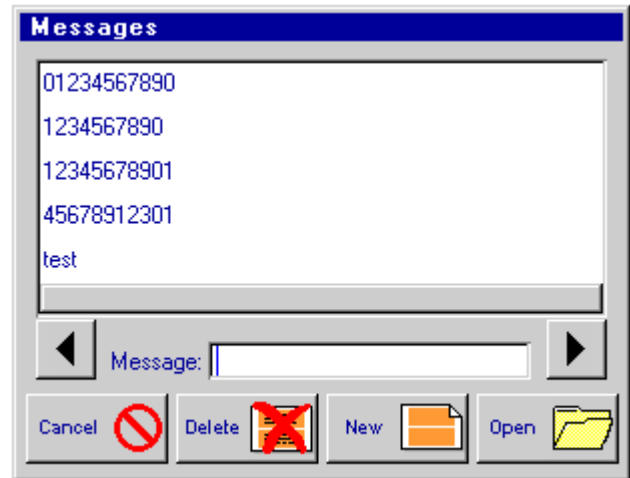

Step 2: Touch the New button.

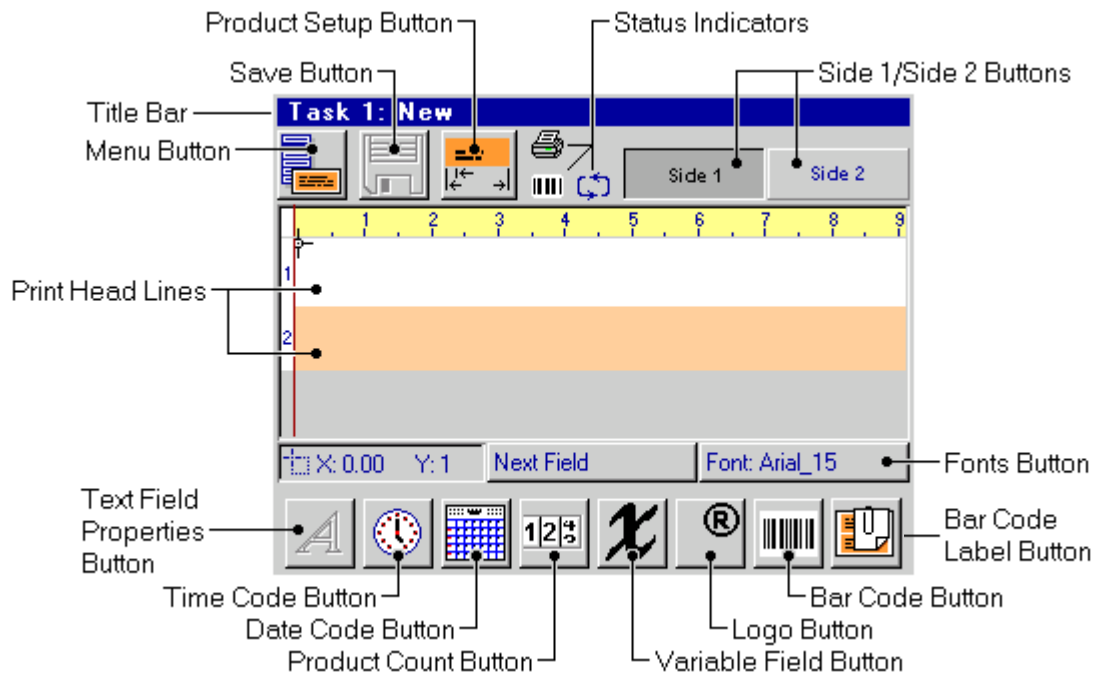

Edit Screen Controls and Features

Title Bar: The Title Bar shows the task for which the message is being created and the name of the message.



Menu Button: Touch the **Menu** button to display the Message menu. From the Message menu, the user can:

- Create a new message.
- Open an existing message for editing or viewing.
- Save a message.
- Do a test print of a message.
- Undo all changes made to a message (Revert).
- Delete all fields from a message (Clear).
- Compute a message's ink consumption (Ink Usage).
- Return to the Home Screen (Exit).

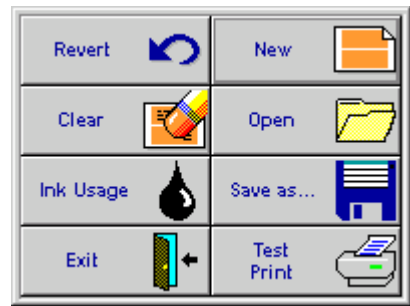

Save Button: A dark blue **Save** button indicates changes made to the message have not yet been saved. The button is "grayed out" when no changes have been made or the changes have been saved.



Product Setup Button:

- Set the product's length.
- Set the print margins.
- Set the print resolution (dpi).
- Select print options.



Status Indicators:

- Displayed when **Test Print** is selected from the Message menu.
- Displayed when the message in the editor is configured for repeat print.
- Displayed when the message in the editor is configured to print upside down.
- Displayed when the message in the editor has an attachment.



Side 1/Side 2 Buttons: Touch **Side 1** or **Side 2** to switch the editor to the corresponding side of the print message.



NOTE: When the system is properly configured, **Side 1** is always the near side of the conveyor, **Side 2** is always the far side.



Fonts Button: Touch the **Fonts** button to select the font for the next field to be added to the print message, or to change the font of an existing field. The name of the current font selection is displayed on the button.



Text Field Properties Button: Used to change the properties of a new or existing fixed text field.



Time Code Button



Date Code Button



Product Count Button



Variable Field Button



Logo Button



Bar Code Button



Message Attachment Button: Touch the **Message Attachment** button to attach a file or text string to a print message. This button is shown only when the COM1 or COM2 function is set to SATO 8485SE, Zebra, or Message Attachments. See "Serial Port Setup" on page 32 for instructions on configuring the COM port.



Step 3: Touch the **Product Setup** button.

Enter the product's length, and the left margin for side one and two, if applicable.

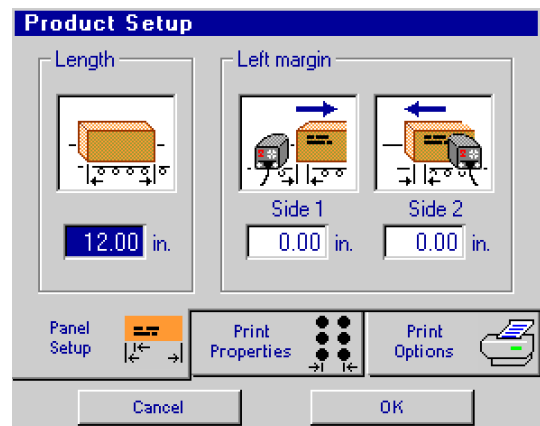

Touch the **Print Properties** tab. select the desired print resolution.



NOTE: Bar codes must use a resolution of 200 dpi.

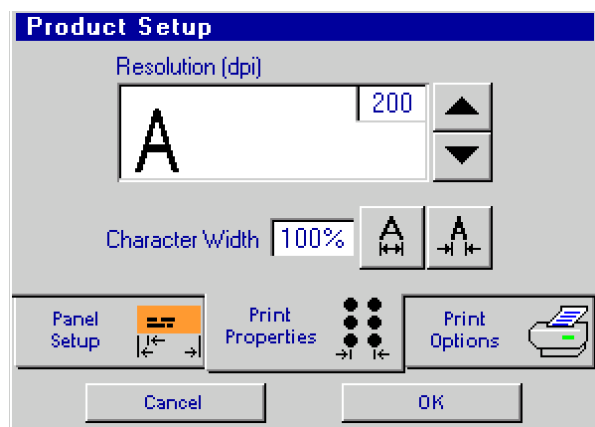

Character Width is used to change the width of all text fields within the message.

Touch the **Print Options** tab.

Select **Side 2 = side 1** to automatically copy to side 2 all fields entered on side 1. The **Side 2 = side 1** option is available only when both sides have the same number of vertical print dots.

Select **Print n times** to automatically cancel printing after the message has printed a specified number of times. The radio button becomes active when **Print n times** is selected. Select the value entry box and enter the number of times the message is to print (from 1-9999), or select prompt to have the Marksman Duo XT ask for the number of prints when the message is selected. This option is often used with message look up when a message is to print just once. See "Serial Port Setup" on page 36 for explanation of Message Lookup

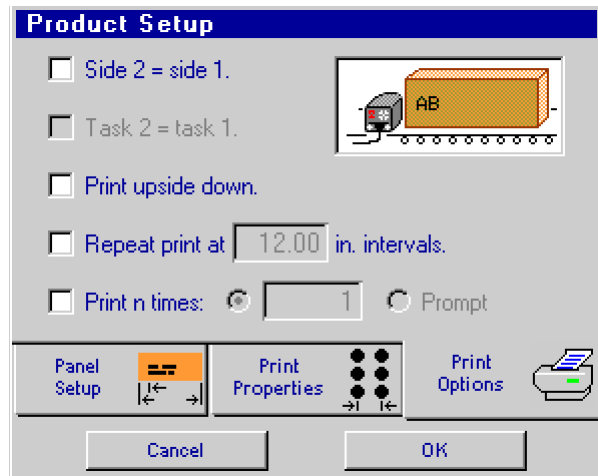

Touch the **OK** button to save the settings and close the Product Setup dialog box.

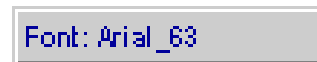

Step 4: Touch the Font button to display the list of available fonts, highlight the selection, and touch OK.

Step 5: Add data fields to the print message.

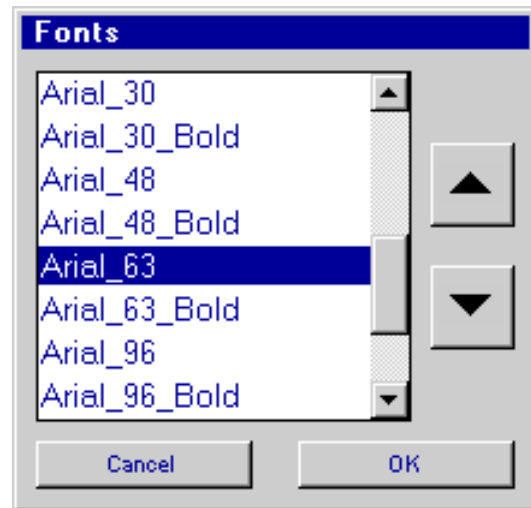

Adding a Text Field

To add a text field to the print message, move the crosshairs pointer to the desired field location and begin typing. To start a new line (a text field may have up to ten lines of text), press and hold the **Ctrl** key and press **Enter**. When finished, press **Enter**. If the field is not exactly where it should be, use the arrow keys to reposition it. Press **Enter** again when the field is at the desired location.

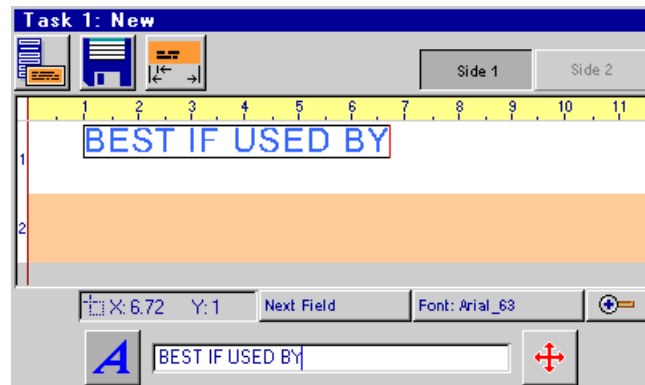



Adding a Time Code

Touch the **Time Code** button. Select a format for the time code.



Adding a Date Code

Touch the **Date Code** button; Select a format for the date code and, if the date code is for a future date, enter the number of days or months until that date in the **Date offset** box.



Adding a Product or Pallet Count

The system can print increasing or decreasing item and pallet counts, with or without leading zeros, in numeric or alpha format. A numeric count may be up to nine digits long; an alpha count may be up to seven digits long.

Product count: Touch the **Product Count** button.

Increasing count: Enter a **Stop at** value that is greater than the **Start at** value.

Decreasing count: Enter a **Start at** value that is greater than the **Stop at** value.

Pallet count: Touch the **Pallet count** radio button and enter the number of items per pallet. A pallet count is incremented or decremented every n items, where n is the number of items per pallet.

Alpha count: Touch the **Alpha count** check box. When **Alpha count** is checked, the contents of the **Start at** and **Stop at** boxes change from numbers to their equivalent alpha values.

There are two alpha count formats. Use the **Print leading zeros** check box to select the format desired.

1. **Print leading zeros** checked. When printing leading zeros, A = 0 by definition, so B = 1, C = 2, etc. The counting sequence is AB, AC, AD, ... AY, AZ, BA, BB, BC, ...
2. **Print leading zeros** not checked. Without leading zeros, A = 1, B = 2, C = 3, etc. The counting sequence is A, B, C, ... Y, Z, AA, AB, AC, ...

A product count is normally increased or decreased by 1 after every print cycle. To increase or decrease the count by a value other than 1, enter that value in the box.



Adding a Variable Field

A variable field is a text field whose contents may change from use to use or print to print. The data printed may be specified by the user, or come through the COM1, COM2, or Ethernet port.

- Select the data source:
User: The user is prompted to enter the data to be printed when the message is loaded to print.

Data 1 - Data 10: Select Data 1 through Data 10 to use a common variable field in multiple locations. Data (1-10) can be selected and assigned a field name. This variable field can be placed multiple times in a message. When the message is printed, the field name will be prompted once for input, and will print the variable data in all locations where Data (1-10) was placed. The field length must be set for each location, as the font size can be changed for each data field. Up to ten different data fields can be placed in multiple message locations.

COM1, COM2: Select **COM1** or **COM2** when the data to be printed is from an external device such as a scale or bar code scanner. Multiple variable fields can use COM1 or COM2, but all will have the same information.

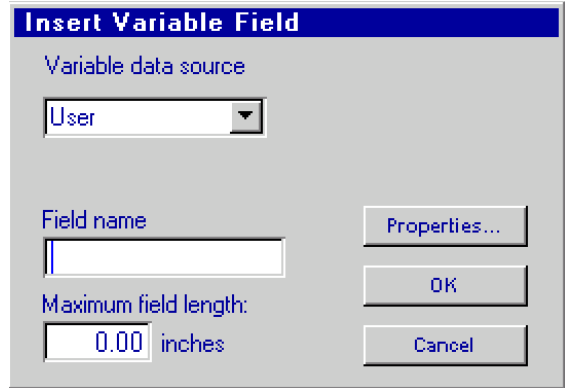

Adding a Logo

Touch the **Logo** button.

Select a logo.

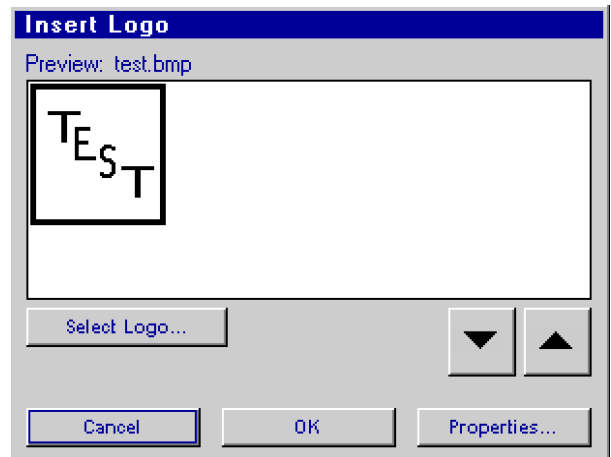



Adding a Bar Code

Touch the **Bar Code** button

- Select the type of Bar Code.
- Choose the source of the bar code data:
Fixed: Select **Fixed** if the bar code data never changes.
User: Select **User** if the bar code data is to be entered when the message is selected to print.

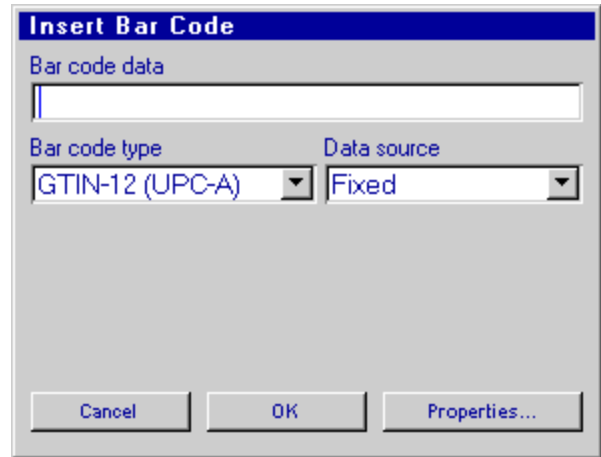

COM1, COM2: Select **COM1** or **COM2** when the bar code data comes from an external device, such as a scale or scanner. To use COM1 or COM2 the serial port has to be configured as External Input (see “*Serial Port Setup*” on page 32). Multiple bar codes in the same print message can use COM1 or COM2, but all will print the same data.



NOTE: The bar code data printed is that which was last received at the specified serial port at the time the message is selected to print, and the data cannot be changed "on the fly." To change the bar code data, first send the new data, then reselect the message to print.

Data 1 - Data 10: Select **Data 1** through **Data 10** to print the same bar code in multiple locations within a message.



NOTE: These Data 1 - 10 sources are the same ones described in “*Adding a Variable Field*” on page 43. If a bar code and variable field are both set to use the same Data 1 - 10 source they will print the same information; once in bar code form and once as text.

Format: Select **Format** if the bar code is to contain time or date information. The **Format** box accepts regular text inputs entered from the keyboard, as well as date and time codes.

- Select the bar code **Magnification** factor. (Not applicable to all bar code types.)
- Enter the **Bar code data**. Except for Code 39, the Firmware automatically calculates the checksum digit and adds it to the end of the bar code data.

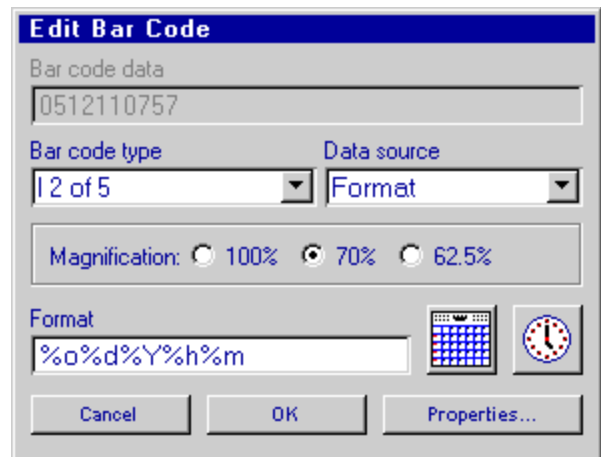

- If the Human readable data is not to be shown touch the **Properties** button, open the **Human readable** fonts list, and select **None**.

The following section describes how to adjust barcodes to accommodate variations in ink bleed on different substrates.

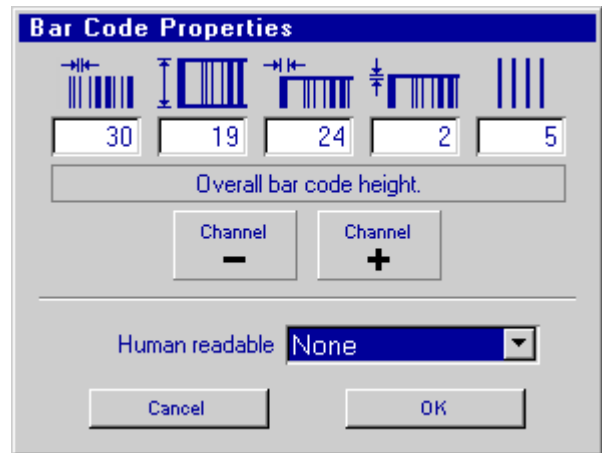

Message with bar code

Measuring Ink Bleed: Insert a bar code field by touching the bar code field button at the bottom of the Edit Screen, then selecting the **Measure ink bleed** bar code type. Print the message on a sample of the substrate to be used in the application and allow it to bleed for at least 24 hours before reading the measurement.

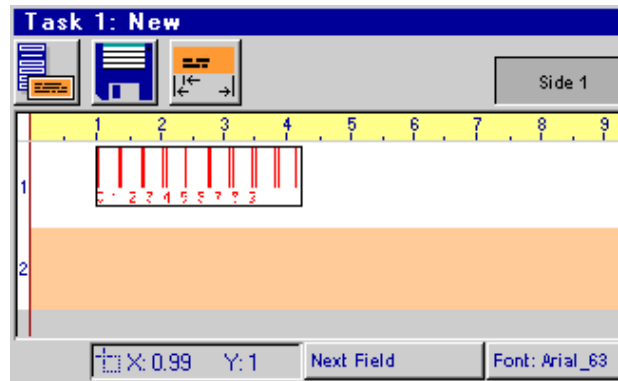
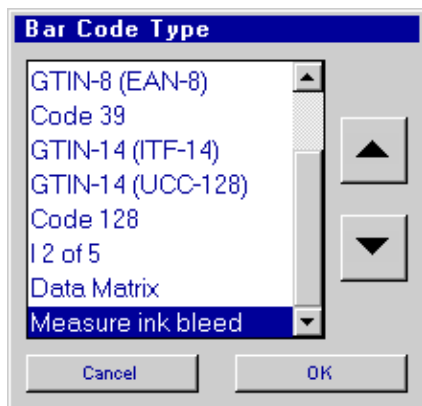

The correct amount of bleed is determined by identifying the first set of bars that have not bled together. In the example, the bleed measurement is 5 (columns).



The measurement is set in the **Bar Code Properties** dialog box.

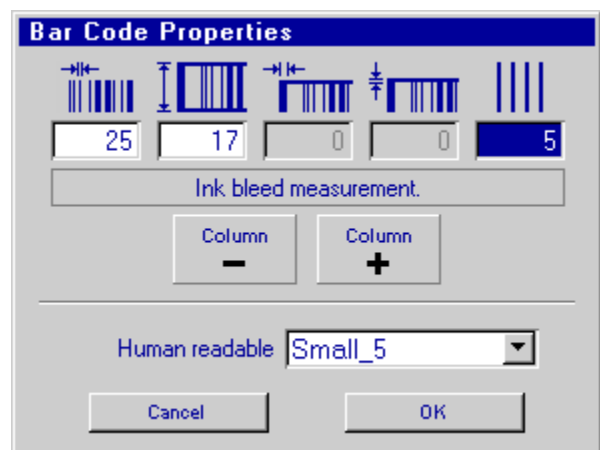

Adding a Message Attachment

A message attachment is a file or text string that is appended to a print message when the message is created or edited. The attached file or text string is then sent out one of the serial ports when the message is selected to print. Message attachments can be used to signal or control devices external to the controller such as PLCs, PCs, label applicators, Linx printers; even another controller.

Message attachments are possible only when **SATE 8485SE**, **Zebra**, or **Message Attachments** is selected as the function for at least one of the two serial ports (see “Serial Port Setup” on page 32 for instructions on configuring the serial ports), which causes the **Message Attachment** button to appear on the Edit Screen.

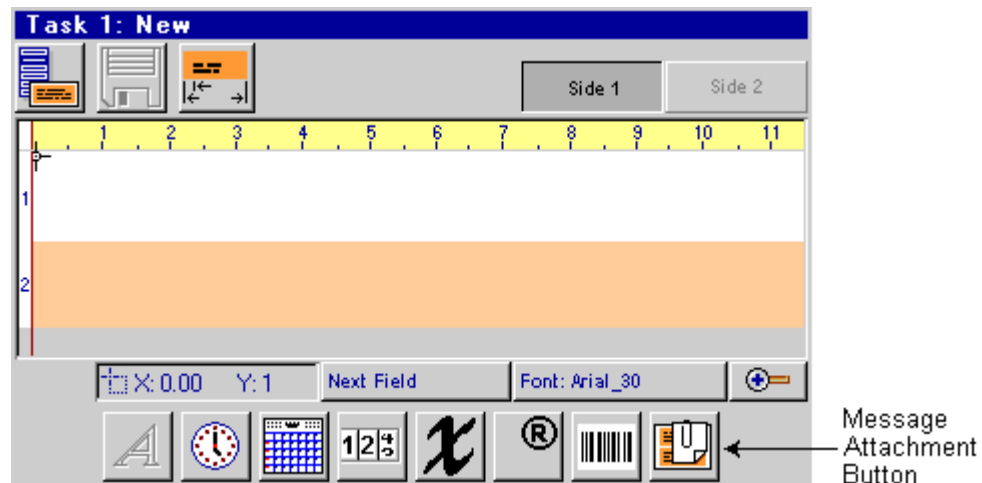

To add an attachment to the print message touch the **Message Attachment** button.

- Select the attachment type: **File** or **Text**.
 - If **File** is selected, touch the **Select file** combo box to display a list of available files. Select a file from the list.

For a file to appear on the list it must be located in the **alps** folder on the controller, and it must have a **.alp** extension. It may be a text or binary file, but it must have a .alp extension or it won't appear on the list. Files can be uploaded to the controller via Ethernet or from a USB memory device.

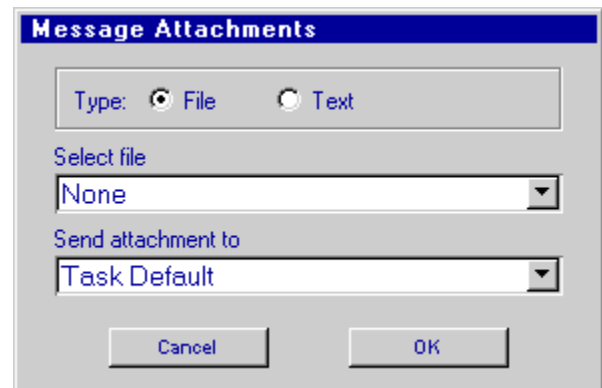

- If **Text** is selected the dialog box changes slightly.

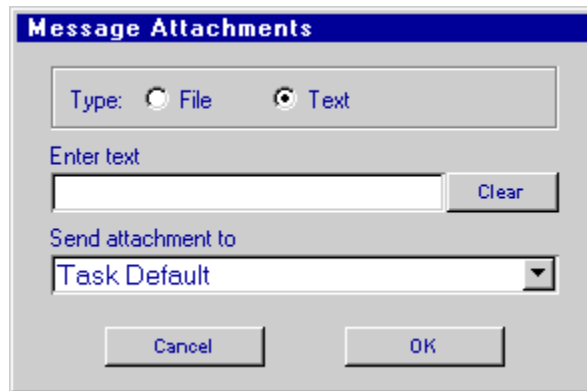

The text entered in the box is sent out the selected serial port when the message is selected to print. If the text needs to be terminated with a carriage return/line feed enter "\r\n". A text attachment can have a maximum of 255 characters, including line terminating characters.

- Select the attachment's destination:
 - **Task Default**: the attachment is sent out the serial port that corresponds to the task used to print the message. That is, if the message is printing on Task 1 the attachment is sent out COM1, if the message is printing on Task 2 the attachment is sent out COM2. The Task Default selection is useful in dual task applications where a print message may be printed on either task.
 - **<selection> @ COM1**: **<selection>** is the COM1 function selected during system set up: **SATO 8485SE**, **Zebra**, or **Message Attachments**. When a COM1 destination is selected the attachment is sent out COM1 regardless of which task is used to print the message.
 - **<selection> @ COM2**: **<selection>** is the COM2 function selected during system set up: **SATO 8485SE**, **Zebra**, or **Message Attachments**. When a COM2 destination is selected the attachment is sent out COM2 regardless of which task is used to print the message.
- Touch the **OK** button to close the dialog box and add the attachment to the print message.



Step 6 Save the print message. Touch the **Save** button.

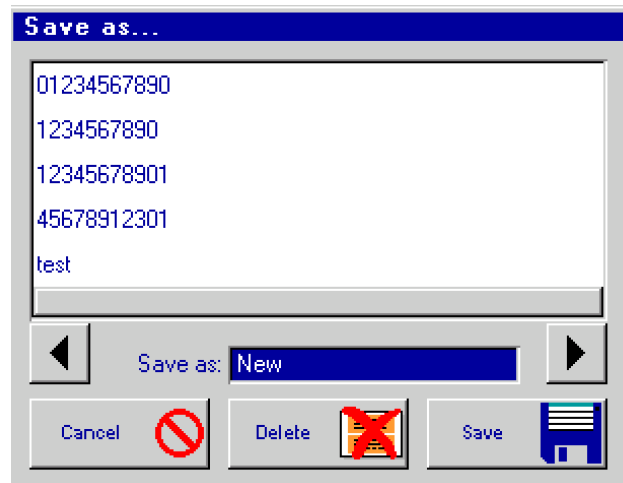

Editing a Message

From the Home Screen:

1. Touch the **Messages** button.
2. Select the message you wish to edit from the list.
3. Touch the **Open** button.

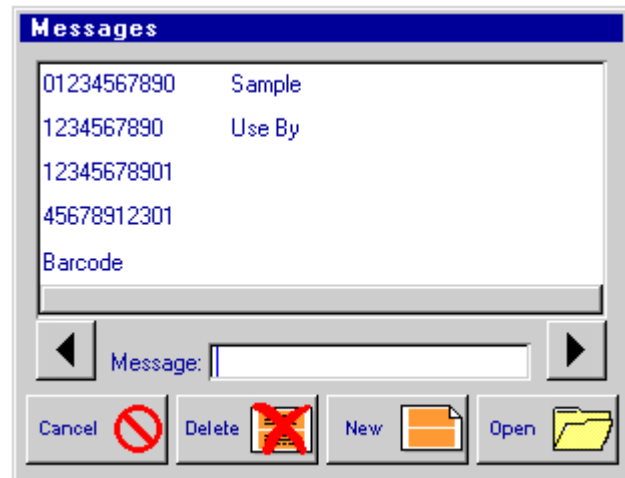

Editing Fields

When selected, all field types, except text fields, are displayed in red and outlined by a black box. When a text field is selected, it is first displayed in light blue. The light blue color indicates the text in the field can be edited. Press **Enter** and the field color changes to red, indicating the field can be moved.

A field can be selected by touching the **Next Field** button, by pressing the **Tab** key, or by touching the field directly.

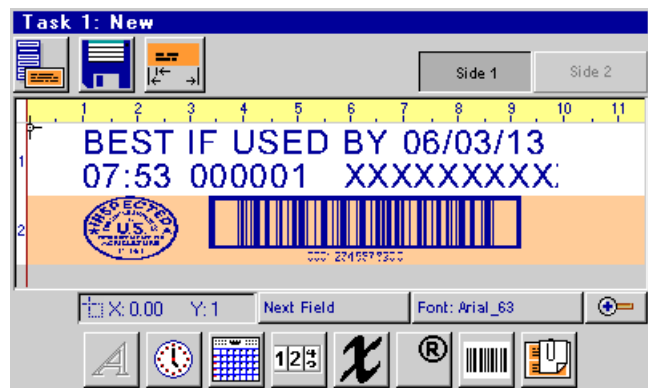

Release a selected field by pressing the **Enter** key, or by selecting another field.

Deleting a Field:

1. Select the field; for a Text field, press **Enter** after it's selected. The field color will change from dark blue to red.
2. Press the **Backspace** or the **Delete** key.

Changing Field Properties:

Text Field:

1. Select the field; its color changes from dark blue to light blue.
2. Touch the **Text Field Properties** button.

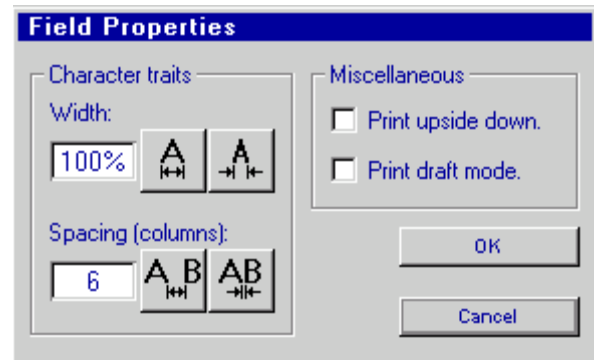

All Other Field Types:

1. Select the field; its color changes from dark blue to red.
2. Touch the corresponding field type button (the button with the dark gray background); the field's Edit dialog box is displayed.
3. Touch the **Properties...** button; the Field Properties dialog box is displayed.
4. Change the field's properties as desired.

Character Width Trait will adjust the width of all characters in the selected text field. The factory default character width settings will produce characters and logos that are proportional to each print head type:

Default Character Width		
<i>Print Head Type</i>	<i>Fonts</i>	<i>Logos (.bmp)</i>
384, 768	200%	300%



NOTE: The global DPI setting should be used to reduce or increase message width. The Character Width determines the number of printed columns in a character. The Character Width setting is intended for use with Impulse Jet print heads.

Print Draft Mode: If this box is checked, every other column of the field will print.

Changing a Field's Font:

1. Select the field.
2. Touch the **Fonts** button.
3. Select the new font.

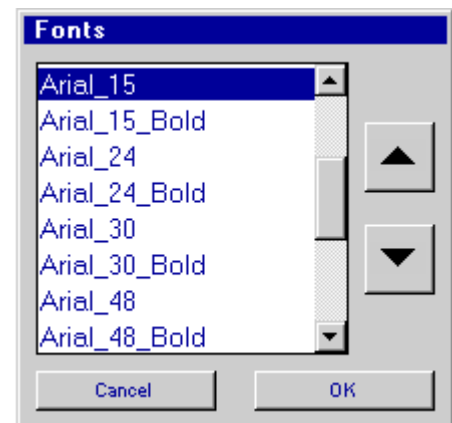

Message Zoom



On tasks configured with 768 or 384 graphics print heads, a **Zoom** button at the lower right corner of the edit window expands the window to full screen, and magnifies the print message so that fine details may be seen (see illustrations below).

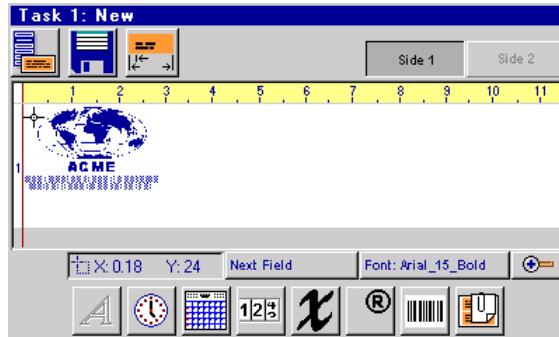

Normal Edit Screen



Edit Screen Zoomed In

When zoomed in, fields may be selected, moved and deleted. Use the **Zoom** button or the **ESC** key to return to the normal Edit Screen.

Edit Screen Keyboard Shortcuts

- Ctrl X** Cut the selected field from the print message.
- Ctrl C** Copy the selected field.
- Ctrl V** Paste (insert) the last field cut or copied at the current pointer position.
- Ctrl S** Save all changes made to the print message.
- Ctrl O** Open a message for editing or viewing.
- Ctrl N** Create a new print message.
- Tab** Move from field to field, or to the first field if no field is currently selected.
- F1** Scroll the edit window left.
- F2** Scroll the edit window right.
- F5** Scroll the edit window up (only when zoomed in).
- F6** Scroll the edit window down (only when zoomed in).
- F4** Show the extended lowercase character dialog.
- F8** Show the extended uppercase character dialog.

Estimating Ink Consumption

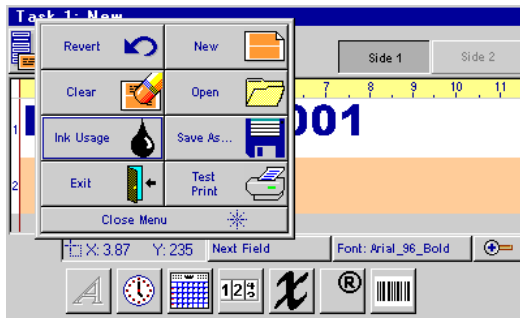

Ink consumption is reported as the estimated number of times the *entire* message will print per 500 mL of ink. All fields on all sides of a print message are included in the calculation.

Side 2 = Side 1: When the **Side 2 = Side 1** option is selected, the total number of dots is determined by counting the number of dots on Side 1 of the message, then doubling it.

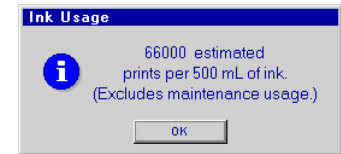

Printing a Message

1. Touch the decorated **Print** button at the top of the **Home Screen** to access print options, then touch the **Print ...** button. Or, touch the **Print ...** button at the bottom of the screen.
2. Select a message to print.

A dialog box is displayed allowing the operator to input the next count value for messages with two or more counts, separate boxes are displayed.

3. To stop printing at any time, open the print options list and touch **Cancel Print**.

Deleting a Message

1. Touch the **Messages** button on the **Home Screen**.
2. On the **Messages** screen touch a message name on the list.
3. Touch the **Delete** button. When prompted to confirm, touch **Yes**.

Making Adjustments During Printing

Product count and variable field data can be changed during printing, as long as the controller has not been set up for Message Look Up, Network Mode, Network Notification or Command and Control. Follow the instructions below for the type of information that needs to be changed.

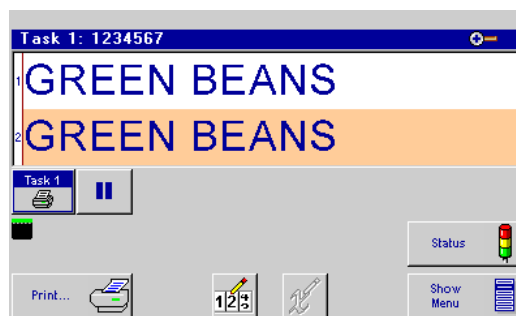

Edit Counts Button

Edit Variable Fields Button



Adjusting Product Counts

Touch the **Edit Counts** button on the Home Screen. The "Total Count of All Products Printed" is a non-printing count that is incremented every print cycle. Touch the **Reset** button to reset this count to zero.

Touch the **Adjust Print Counts...** button to change the value of any printable count the current print message may have. If the current message has no counts, the **Adjust Print Counts...** button is grayed out.

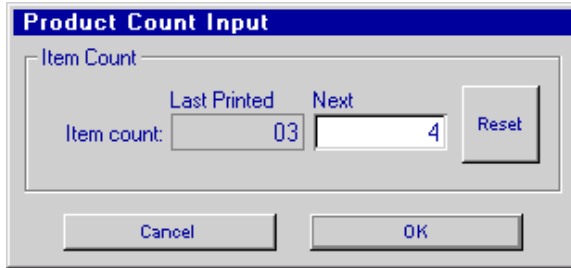
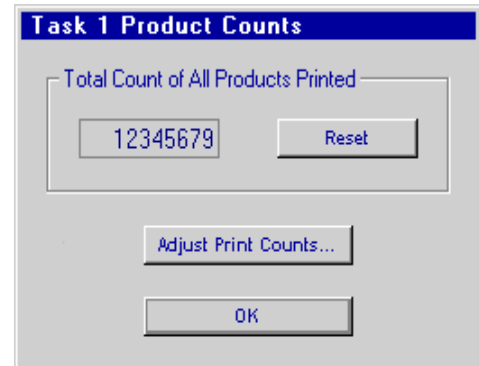

Product Count Input dialog box for an item count.

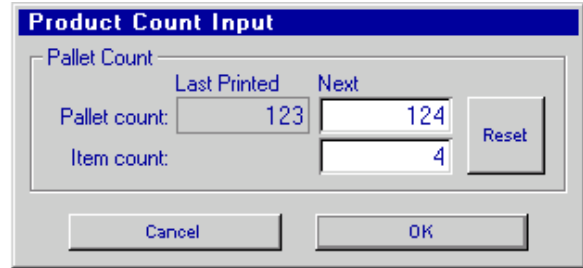

Product Count Input dialog box for a pallet count.



NOTE: The **Item Count** on the Pallet Count dialog is a count internal to the pallet count. It tracks the current number of items on the pallet. When this count reaches the defined items per pallet, the pallet count is incremented. This Item Count does not print. It is provided for those who want to print a pallet count only. If both a pallet count and an item count (for example, BOX 4 OF PALLET 124) are being printed, a separate Product Count Input dialog box will be shown for each count. To keep the item-pallet counts properly synchronized, the printable Item Count ('4' in the left illustration above) must match the Pallet Count item count ('4' in the right illustration above).



Changing Variable Field Data

Touch the **Edit Variable Fields** button.

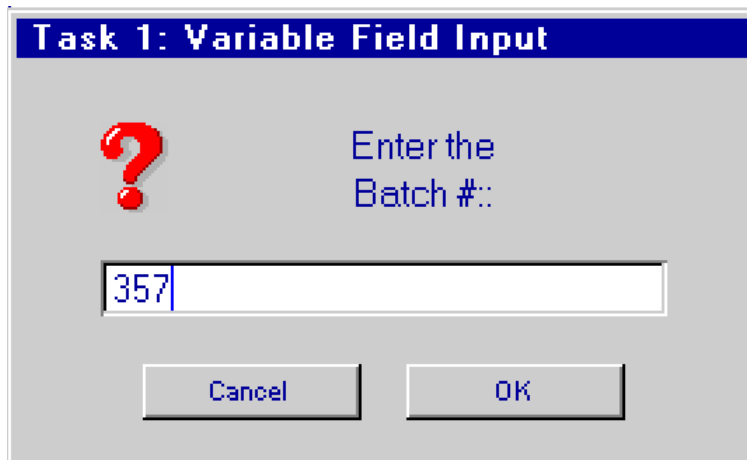

Section 9: Utility Functions

User Access Control

Access to any or all of the various controller functions may be controlled by means of a user password. Which functions are made accessible to everyone and which are password protected is set on the User Access Screen. The password is also set or changed from the User Access Screen. To display the User Access Screen touch the **Control Panels** button on the Home Screen, then the **User Access** button.

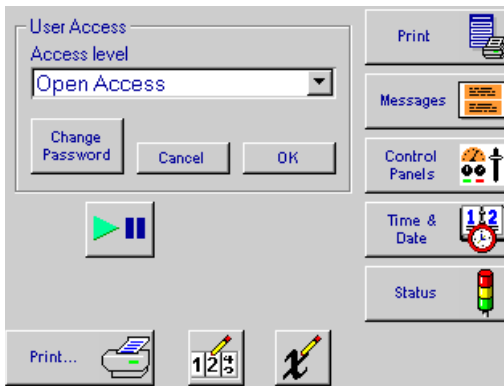

User Access Screen showing Open Access

The controls for setting the access level, and setting or changing the password, are in the **User Access** box at the screen's upper left. The rest of the screen mimics the Home Screen, and shows which functions are accessible and which are locked out under the different access levels.

Setting the Access Level

Touch the Access Level combo box to select the access level:

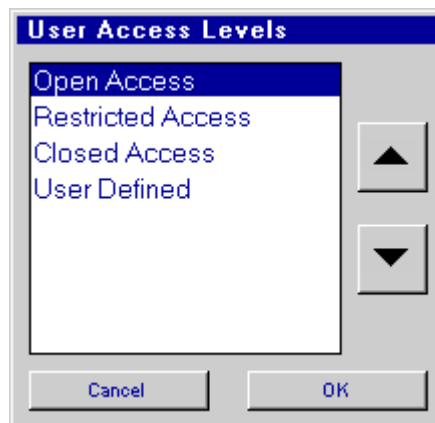

Open Access: Password protection is turned off, and all controller functions are available to everyone.

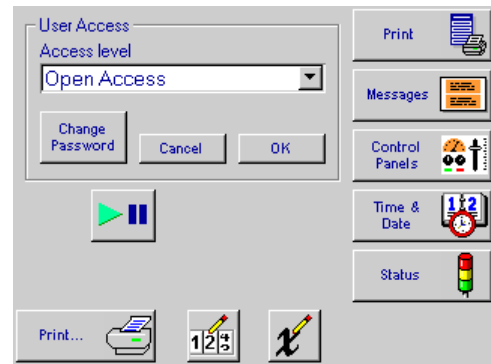

Restricted Access: The Print, Messages, Control Panels, and Time & Date buttons are locked. The operator can still pause and resume print, change the print message (but not cancel it), edit print counts and variable fields in the current print message, and check system status.

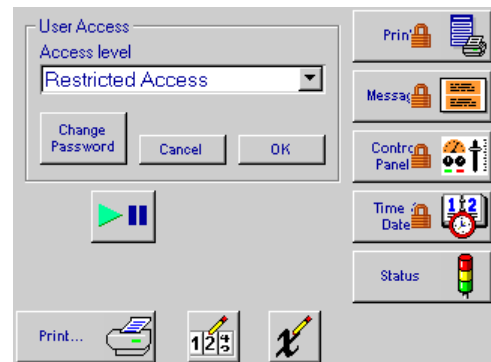

Closed Access: All buttons except the Status button are locked. The operator can only check system status.

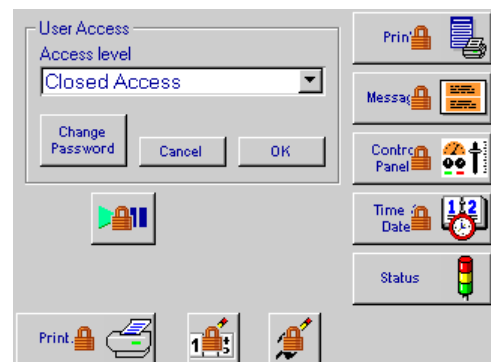

User Defined: The user determines which buttons on the Home Screen are locked. Touch an unlocked button to lock it, touch a locked button to unlock it. The illustration shows the Messages, Control Panels, and Time & Date buttons are locked, denying access to all system setup functions, but allows the operator to pause and resume print, change or cancel the print message, edit print counts and variable fields for the current print message, and check system status.

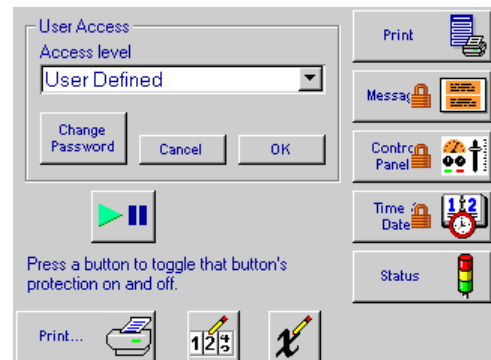

Changing the Password



The factory-set password is **Manager**. To change the password touch the **Change Password** button.

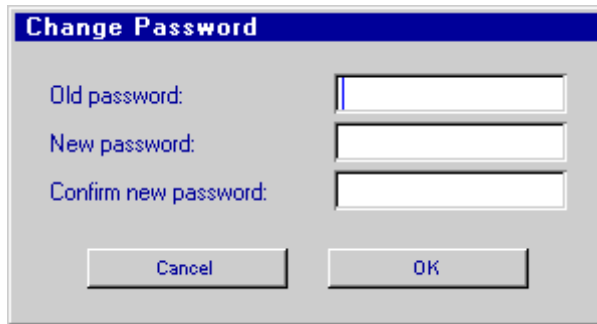

Enter the old password (“Manager” if changing the password for the first time), the new password, and then the new password again. Passwords are case sensitive, can be up to 16 characters long, and may contain any alphanumeric character, symbol, or punctuation mark.

When any controller functions are password protected, the **Show/Hide Menu** button on the Home Screen is replaced by a smaller **Show/Hide Menu** button, and a **Lock/Unlock** button. The Home Screen also indicates which functions are password protected by displaying a small lock symbol on the locked buttons.

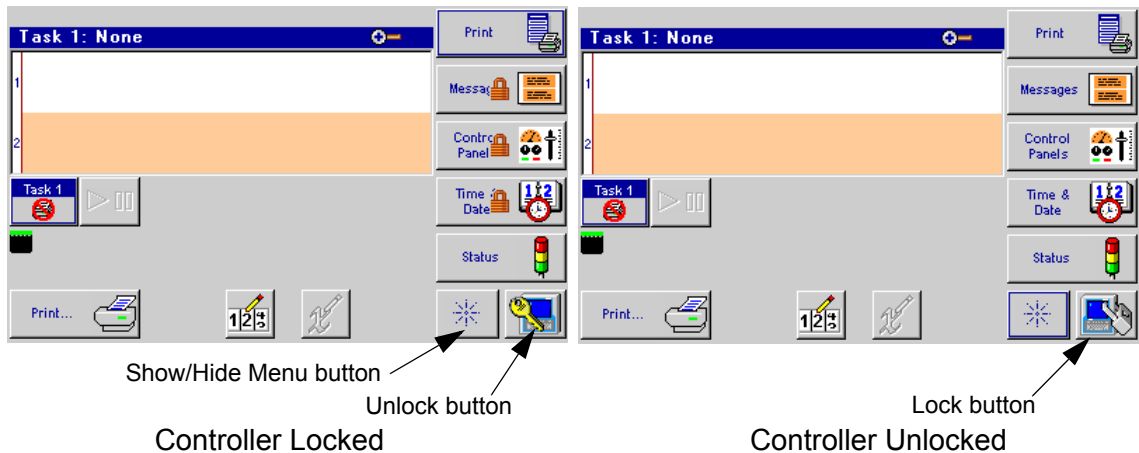

Touch the **Unlock** button to unlock the protected functions.

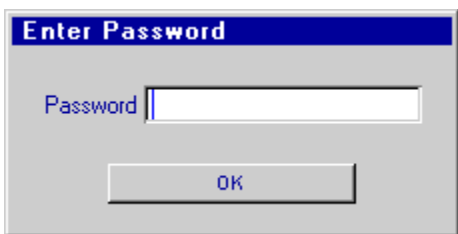

Touch the **Lock** button to lock the controller against unauthorized access.

Status Screen

- ✓ Touch the **Status** button on the **Home Screen**.
- ⚡ Touch the buttons along the bottom of the status window to display the current status of the Print **Task** or system **Memory Usage**. Indicators on the buttons give an "at a glance" indication of print task status and memory usage. A green checkmark indicates normal print task operation or memory usage, a yellow dash indicates an item needs attention and a red 'X' indicates a non-operational print task or maximum memory usage.
- ✗

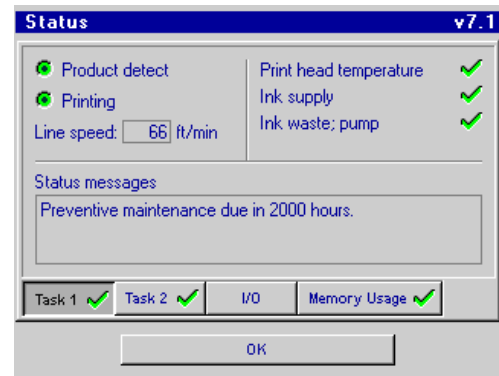

The illustration above shows the status display for an Impulse Jet task.

All print task status indicators are updated once every two seconds.

I/O Status

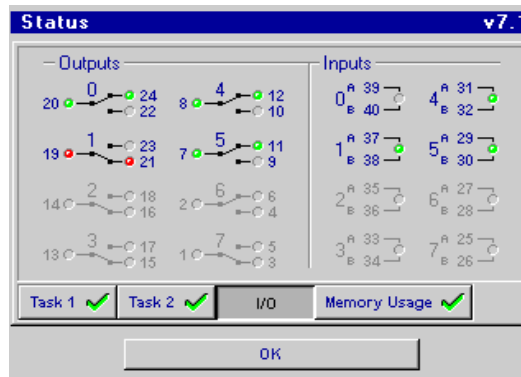

The I/O Status Screen becomes available when a function is assigned to one or more of the I/O channels. (See the **I/O Board Kit Installation Instructions** for directions on setting up the I/O card.) Indicators on the I/O Status Screen show the current state of the I/O card's relay outputs and isolated inputs, and are updated every two seconds.

Relay Output Indicators:

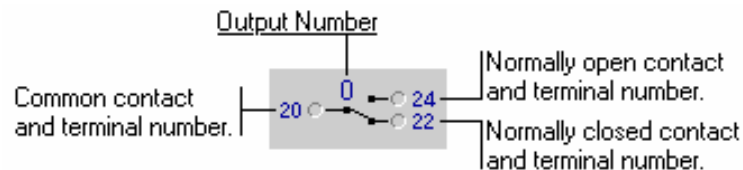

Indicates the output function is undefined, or "None".



Indicates the relay is de-energized (common contact and normally closed contact are red).

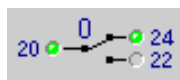

Indicates the relay is energized (common contact and normally open contact are green).

Input Indicators:

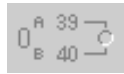
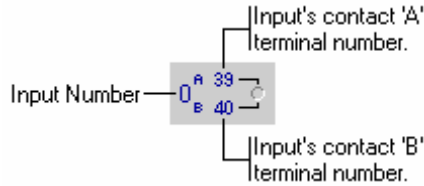

Indicates the input function is undefined, or "None".

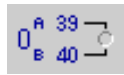

Indicator is off (gray); the input signal is inactive.

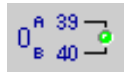

Indicator is on (green); the input signal is active.

Manual Control of Relay Outputs

An output relay assigned the **Manual On/Off** function may be manually energized and de-energized from the I/O Status screen by touching the relay's on-screen indicator. Touch it once to energize the relay; touch it again to de-energize it.

System Test

Touch Screen Calibration is completed at the factory. Re-calibration can be performed any time there are problems with the touch screen. From the **Home Screen**, select **Show Menu, Control Panels**, then **Utilities**. Choose **Calibrate Touch Screen** and touch **Do Function**.

If the touch screen is so far out of calibration that it is inoperable, you will have to call up the calibration utility using the keyboard. From the **Home Screen**, press the space bar to display the Home Screen menu (the space bar alternately hides and displays the menu), then press the "T" key.

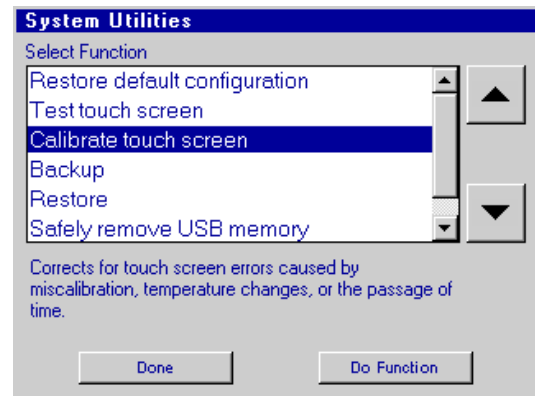

Follow the instructions on the display.

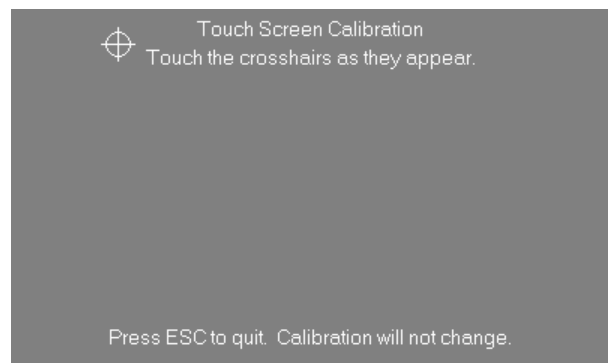

Regional Settings

On the **Home Screen**, touch **Control Panels**, then **Regional Settings**.

Select the language and desired units of measure.

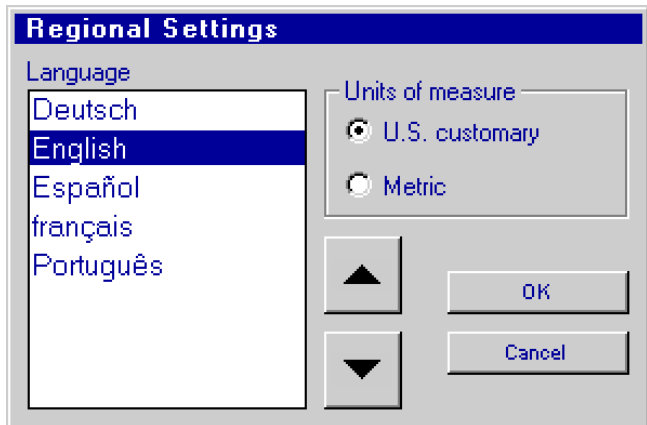

Units of Measure	Line Speed	Print Head Size	Margins, X Coordinate, Product Length
U.S. customary	ft/min	inches	inches
Metric	m/min	mm	cm

Extended characters that are not on the standard keyboard may be used for File Names, Shift Codes, User Codes and Variable Field names. To use extended characters, select the message or field to be changed. Press the **F4** key to bring up lowercase characters, or **F8** (Shift + F4) to bring up uppercase characters, then select the appropriate character.

À	Á	Â	Ã	Ä	Å	Æ	Ç
È	É	Ê	Ë	Ì	Í	Î	Ï
Ñ	Ò	Ó	Ô	Õ	Ö	×	Ø
Ù	Ú	Û	Ü	Ý	ß		
§	¢	£	×	¥	©	®	*



NOTE: Extended characters are only available with Impulse Jet 384/768 fonts, from 9 to 96 dots. Extended characters are not selectable for the Arial 126 dot font.

System Reboot

Should the system ever become unresponsive or display an "Out of memory" message, a "system reboot" must be performed. Press and hold **Ctrl** and **Alt**, then press the **Del** button.



CAUTION: Any message that was printing when the system locked up will automatically resume printing when the system reboots.

File Operations

Backup

To perform a backup of the data files on the system, open the System Utilities Screen, choose **Backup**, and touch **Do Function**.

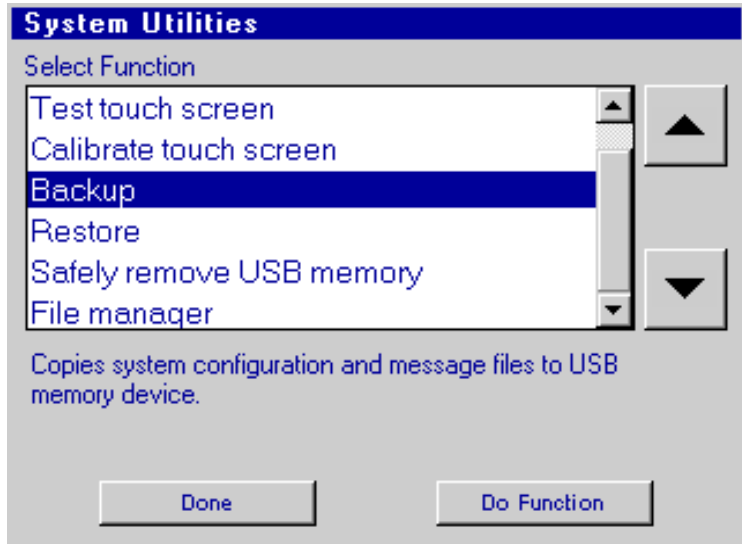

Restore

To perform a restore of the data files on the system from a backup file, open the System Utilities Screen, choose **Restore**, and touch **Do Function**.

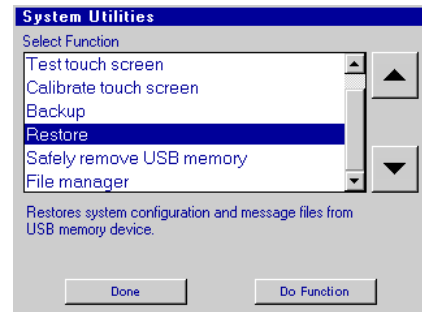

Safely Remove

To perform a safe removal of your USB media, open the System Utilities Screen, choose **Safely remove USB memory**, and touch **Do Function**.



CAUTION: Corruption of data on the USB memory device can occur if this step is not performed.

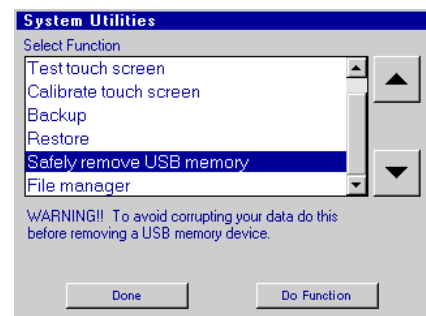

File Manager

Open the System Utilities Screen, choose **File Manager**, and touch **Do Function**.

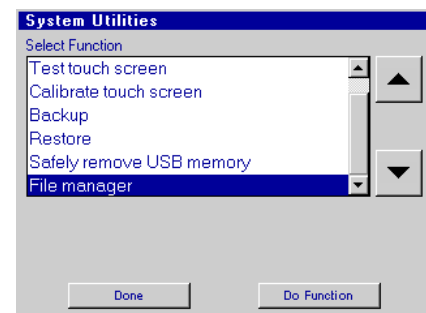

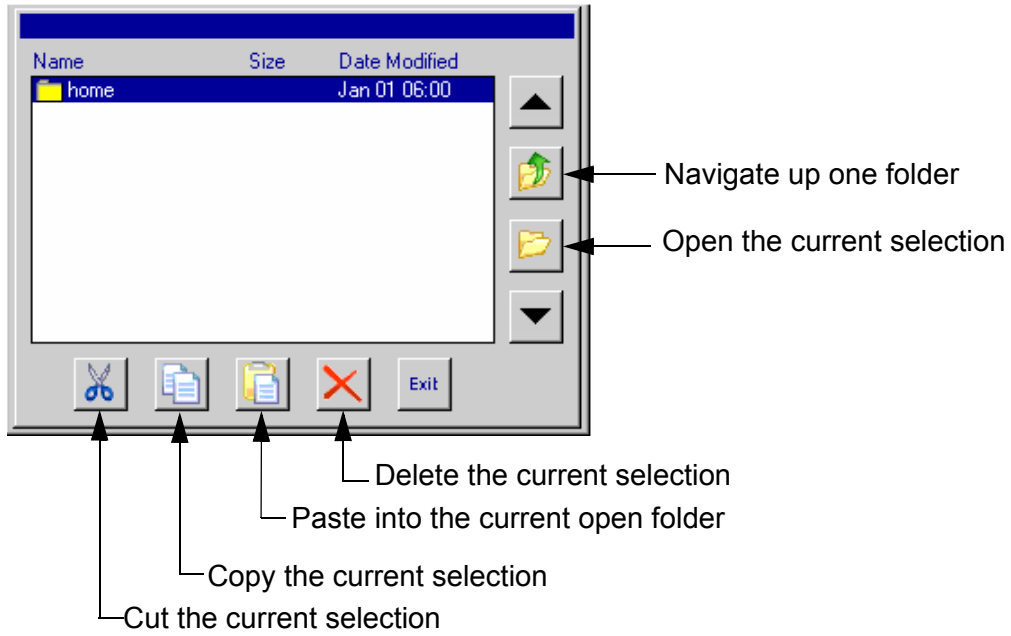

Section 10: Maintenance

System Maintenance

Intermittent (as required):

1. Be sure the photosensor is clean and free of debris.
2. Be sure the O-rings on the encoder wheel are present and not worn.
3. Be sure the nuts and bolts holding the bracketry in place remain tight.

Annually:

Replace encoder O-rings (5765-206).
Recalibrate Touch Screen.

Print Head Maintenance, ScanTrue II Porous Ink

Daily/Shift Startup



Wear safety goggles when working with industrial inks or solutions!

Spray the appropriate cleaning solvent on a lint-free cloth and lightly wipe the front of the print head to remove foreign debris.

Run the an APS cycle for each print head.

It is recommended that the system remain powered on for normal day to day operation.

Shutdowns of Seven Days or Longer

Shutdown:

1. Turn off the controller power switch from the keyboard.
2. Spray the appropriate cleaning solvent on a lint-free cloth and lightly wipe the front of the print head to remove foreign debris. Install long term shutdown gasket (Kit 5760-857) and ship cap on print head.

Startup:

1. Remove ship cap and log term shutdown gasket before power up and allow the print engines to heat up (approximately 5minutes). Spray the appropriate cleaning solvent on a lint-free cloth and lightly wipe the front of the print head to remove foreign debris.
2. If system is equipped with the Automatic Cleaning System (ACS), run the cleaning cycle for each print head.



NOTE: The shipping cap must be removed, or the vacuum pull from the APS cycle will corrupt print quality and potentially start an ink syphon of the reservoir and bottle.

Print Head Maintenance, Non-Porous A5000 Ink

ACS – Automatic Cleaning System

- One automatic cleaning is recommended every **four** hours.

Daily/Shift Startup

- Excess corrugate debris, angel hair (glue), and dried ink must be removed from the stainless steel front plate. Use lint-free cloths and NP solvent spray.
- Once per shift / day, use a sponge swab during an ACS cycle.
 - Have a sponge swab ready.
 - Press the ACS button on the rear of the print head.
 - While the automatic solvent flushing system is dispensing Solvent, agitate the orifice plate with the side edge of the sponge swab. Do not scrub hard. Light agitation is all that is necessary.
NOTE: **DO NOT** use anything but a sponge swab for agitation.
 - When the ink starts dispensing, stop sponge swab agitation. Discard the sponge swab.
 - With a lint-free cloth and spray solvent, spray the solvent into the lint-free cloth, and then wipe off any excess ink from the front stainless steel plate. Discard the lint-free cloth.

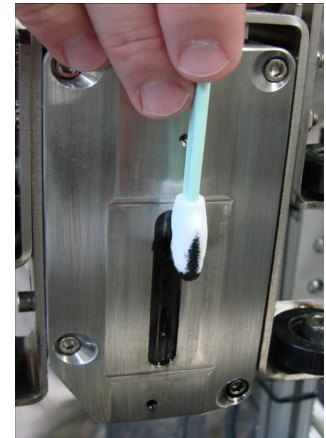

Shutdowns for less than Seven Days

- Ensure the print message is paused or cancelled.
- Loosen the dovetail knob screws and pull the head back away from the print area.
- Run and Automatic Cleaning System (ACS) cycle with foam swab agitation.
- Using solvent spray, wipe off any excess debris and/or ink buildup on the print head.

Shutdowns of Seven Days or Longer

- Remove the DB-25 print head cable from the rear of the head.
- Clean and install orifice plate filler seal.
- Clean and install orifice plate front storage cap.
- Install vent cap on the rear of the print head (male luer fitting).
- If the print head is removed from the print area, disconnected ink and solvent lines and mating fittings on the print head must be thoroughly cleaned with solvent spray.

Startup (short-term)

- If the equipment has not printed in hours / over night, then press the ACS button on the rear of the print head.
- Agitate with sponge swab during solvent dispensing.
- Stop when ink flows.
- If some channels are missing, an Auto-Prime can be performed. Press and hold the ACS button on the rear of the print head. Wait until the light on the ink supply flashes once, and then release the button. Ink only will flow through the orifices.

Startup (after long-term)

- Install any and all ink and solvent lines.
- Remove the vent cap from the rear of the print head.
- Remove the front storage cap and orifice seal.
- Install the DB-25 print head cable and allow to heat.
- Follow Startup (short-term) instructions.

Preventive Maintenance

1. Occasionally there will be debris build up on the front of the print engine face that will require more attention. Typically this debris comes in the form of corrugate, dust, glue, or the like.
2. The method for flushing the debris down will require the Automatic Cleaning System (ACS), Impulse Jet Maintenance Spray (5760-695) for porous inks and (5760-861) for non-porous inks, a soft sponge swab (5760-832) and lint-free cloths (6600-171).
3. Wipe debris and "angel hair" glue off the front plate area with a lint-free cloth and Impulse Jet Maintenance Spray.
4. Lightly soak a sponge swab with maintenance spray and rub up and down in print channel.

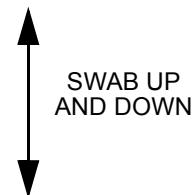
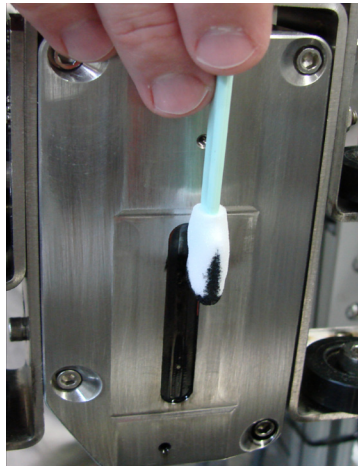

5. Press and hold the Purge button on the rear of the print head for .5 to 1 second. The ACS cycle will initiate.

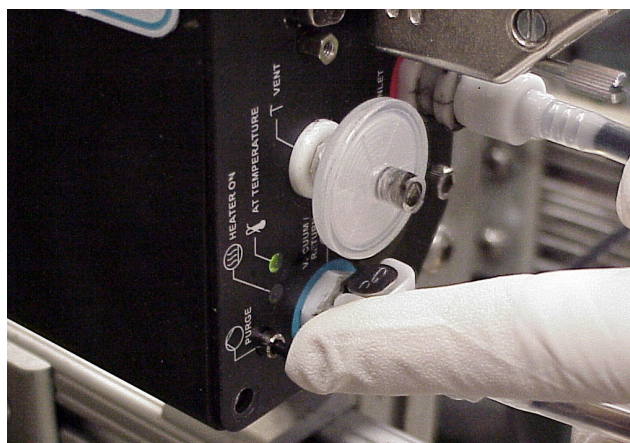

6. Wipe the front of the print head with the lint-free cloth and maintenance spray to remove any excess ink.
7. Repeat steps 3 through 6 as required.

Annually

1. Replace the vent filter on the rear of the print head.

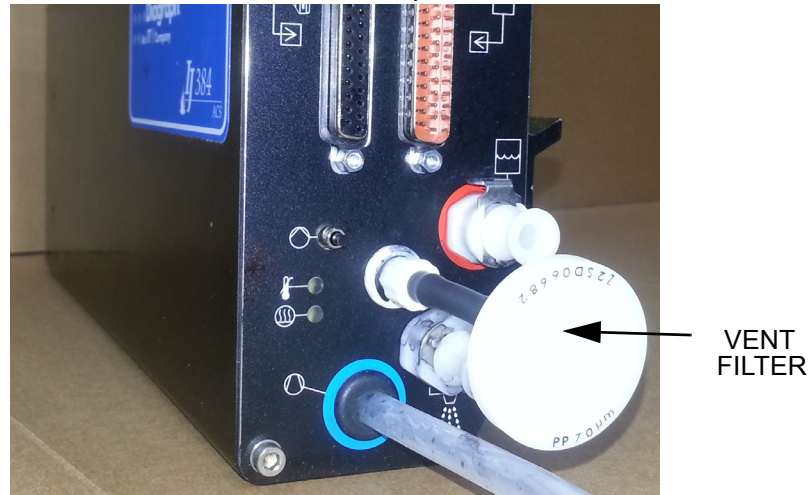

2. Depending on desired quality of print, print heads may need to be returned to the factory for ultrasonic cleaning of the orifice plate and review of the print head plumbing.
3. Clean the Combo Fitting in the vacuum line.

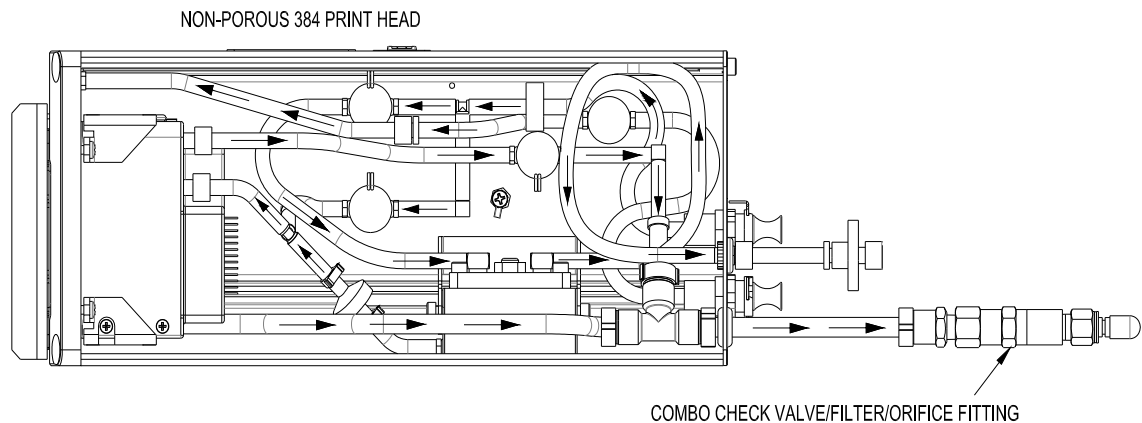

Disassemble the fitting (as shown), clean and re-assemble.

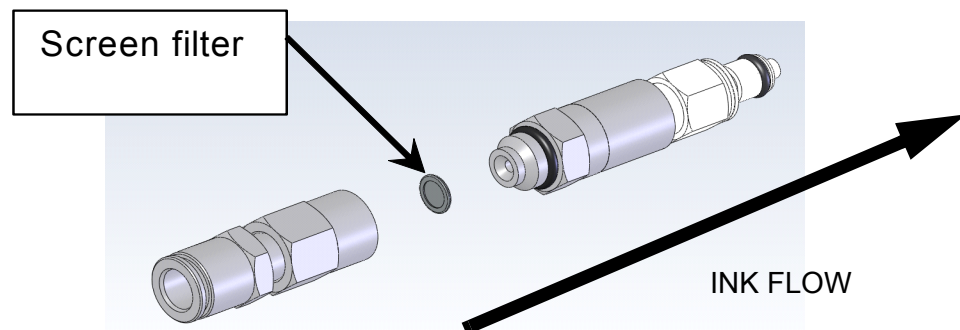

ACS - Automatic Cleaning System



NOTE: If the beacon on the Pro-Series IS is in any way illuminated or flashing, the ACS will not Activate, Make sure all ink faults are corrected before attempting an ACS.

The ACS is an invaluable tool for routine cleaning of loose debris from the print engine face. The images below demonstrate print before and after the ACS.



BEFORE ACS



AFTER ACS



NOTE: The duration of the ACS cycle is approximately 5 - 10 seconds.

This feature can be accomplished by three methods.

1. From the print head:
Press and hold the Purge button on the rear of the print head for. 5 to 1 second. The ACS cycle will initiate.
2. From the controller **(NP only)**:

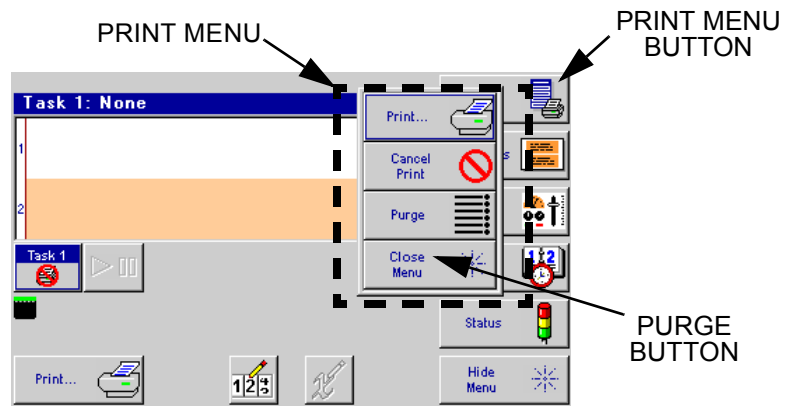

HOME SCREEN

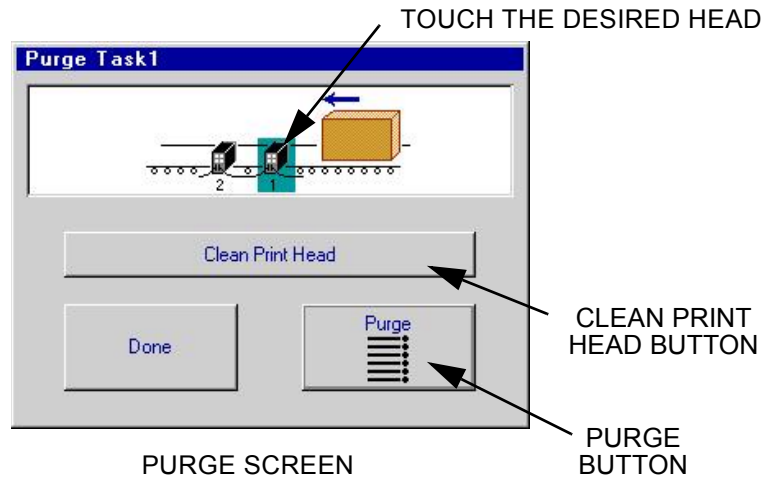

PURGE SCREEN

From the controller **Auto Clean Setup (NP Only)**: The Controller can also be programmed to automatically clean the print heads during regular down times in the production schedule.

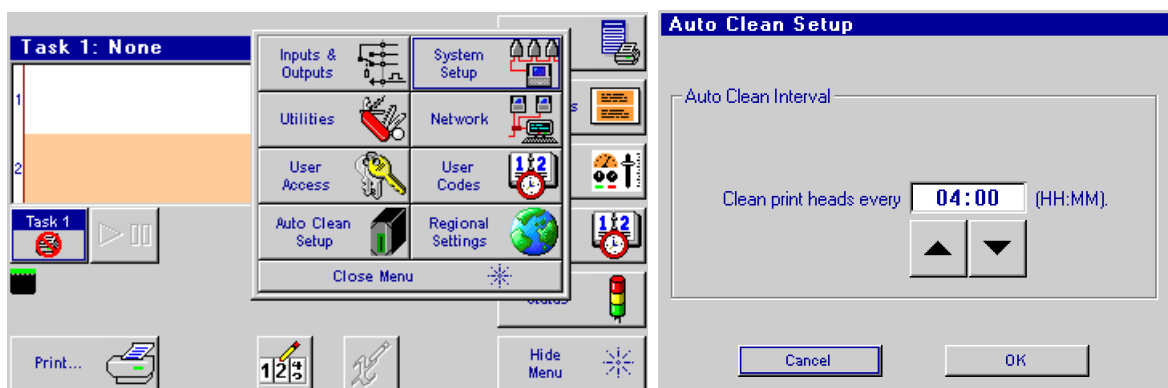

Pro Series IS Maintenance

Changing Ink Containers



CAUTION: Replace ink only with the same type of ink as originally shipped with the unit.

The Ink Status Beacon illuminates when the ink bottle is empty, and the pump is disabled. This alerts the operator to ready a new bottle of ink, and allows the operator at least five minutes to change the bottle before printing is disabled. If the ink bottle is not replaced within five minutes, print will be disabled on all "Tasks" and the beacon will flash slowly.

Annually

Replace the vent filter on the Centralized Ink Delivery System (CIDS).

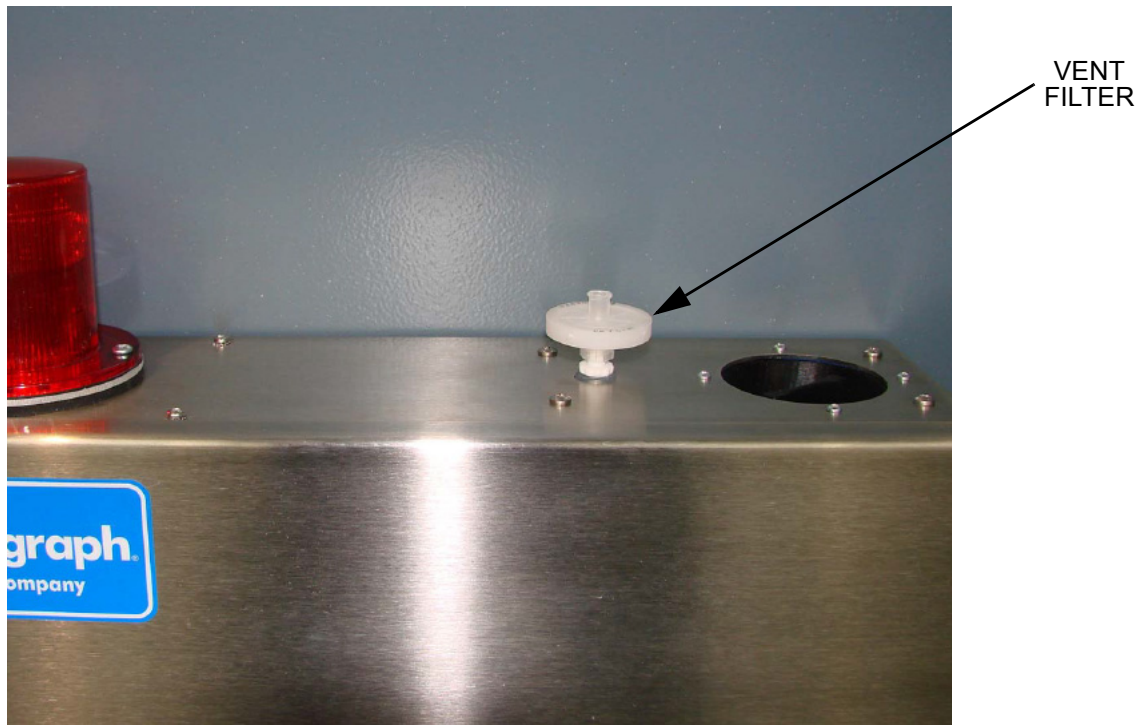

Section 11: Trouble Shooting

Controller

Most controller problems will be the result of improperly connected cables. Check all connections, including power interface, print heads, encoder, and photosensor.

Marksman Duo XT controller:

System Symptom	Possible Cause	Operational Test Method
No Controller power, no Green LED indicator light on CPU.	Power Supply	Check Power Supply light indicator. Check for 24V output for Pro Series or 15V output for VxJet. Check connector between CPU & first Interface Board (CPU JP1 and Interface JR1).
Touch Screen not responding, difficult to select/pick boxes	Touch Screen/Display Assembly	Run system test and re-calibrate Touch Screen.
No response from keypad entry	Keypad Assembly	Inspect flex cable for damage, particularly at end going into CPU connector.
System not responding	CPU Board	Check for Green LED to indicate power. Check for Yellow LED. Flashing indicates CPU is operating. If CPU is not responding, reset by completing: Cntrl/Alt/Del . If system does not restart, complete hard reset by removing power for 10 seconds. Test power at following points: TP1 = Backlight Voltage Supply is 12V when controller is on, 0V when controller is off. TP3 = 3.3VDC TP5 = 5VDC
Touch Screen not responding	CPU to Display PCB Cable	Inspect CPU to Display Cable for nicks or abrasions.

Pro Series IS:

System Symptom	Possible Cause	Operational Test Method
Ink not pumping to Print Head	Power Supply	Ensure Pro Series IS switch is turned on. Check for Power LED on Internal Power Supply Board. If LED is illuminated, check power supply output on P2. It should be 12VDC.
	PC Board	Check the LED indicators and connector voltages on the board. LED4: Green; indicates a print head is signaling for the Liquid Pump to turn on. LED5: Red; indicates the Waste Bottle is full. LED7: Yellow; indicates ink is low in the CIDS Reservoir. J3: Liquid Pump connector; 12VDC when Liquid Pump is on.
	Liquid Pump	Check for 12VDC at the pump. If there is no pumping, or pump sounds weak, replace the pump.
No vacuum at Print Head during ACS Cycle. Ink is overflowing the Print Head	Power Supply	Ensure Pro Series IS switch is turned on. Check for power LED on Internal Power Supply Board. If LED is illuminated, check power supply output on P2. It should be 12VDC.
	PC Board	Check the LED indicators and connector voltages on the board. LED3: Green; indicates a print head is signaling for the Vacuum Pump to turn on. LED5: Red; indicates the Waste Bottle is full. LED6: Red; turns on, off, and flashes with the beacon. Off indicates ink is OK, On indicates ink is low, Slow Flash (1Hz) indicates ink is out, and Fast Flash (6Hz) indicates that the Waste Bottle is full or the pump was turned on for more than 15 seconds. J4: Vacuum Pump connector; 12VDC when Vacuum Pump is on.
	Vacuum Pump	Ensure all tubing is connected between the Print Head and the Pro Series IS. Make sure the Ink Separator Bottle is fully tightened. Open CIDS and remove any clogs in the line. Initiate an ACS Cycle, and listen for the pump. Check for 12VDC at Vacuum Pump.

Pro Series IS (continued)

System Symptom	Possible Cause	Operational Test Method
Liquid Pump and Vacuum Pump do not turn on, and light is off on power switch	Power Supply	Ensure switch is turned on. Check for power LED on Internal Power Supply Board. If LED is illuminated, check power supply output on P2. It should be 12VDC.
Beacon light does not illuminate at ink out	Power Supply	Ensure Pro Series IS switch is turned on. Check for power LED on Internal Power Supply Board. If LED is illuminated, check power supply output on P2. It should be 12VDC.
	PC Board	Check the LED indicators and connector voltages on the board. LED5: Red; indicates the Waste Bottle is full. LED6: Red; turns on, off, and flashes with the Beacon. Off indicates ink is OK, On indicates ink is low, Slow Flash (1Hz) indicates ink is out, and Fast Flash (6Hz) indicates the Waste Bottle is full or the pump was turned on for more than 15 seconds. J5: Power connector; 12VDC when power is turned on. J1: Beacon connector; 12VDC when Beacon is on.
	12V Beacon Bulb	Unplug the Beacon from the board and check the resistance of the bulb. If the bulb is open, replace it.

Pro Series 384 NP Print Head

System Symptom	Possible Cause	Operational Test Method
ACS Cycle will not operate	No Pro Series IS to Controller Cable connection. No Pro Series IS power. No Controller to Print Head connection.	Inspect Pro Series IS communication cable and ensure connection to Interface Board. See <i>Section 4: Installation, Electrical Cable Connections</i> .
	PC Board	Check the LED indicators on the board. LED1: Green; indicates Print Head is requesting IDS to turn Vacuum Pump on. LED2: Green; indicates Print Head is requesting IDS to turn Liquid Pump on. LED9: Green; indicates Intake Solenoid Valve is open. LED8: Green; indicates Print Head Reservoir is full. LED3: Green; indicates Print Head Reservoir is low and Ink Out Timer has expired.
Ink overfills and drips after ACS Cycle	Waste Bottle not tightened. Vacuum line disconnected, exceeded maximum vacuum line length, or vacuum line coiled.	Inspect Waste Bottle and ensure bottle is tight. Inspect vacuum line and connections. See <i>Section 4</i> for maximum line lengths and installation requirements.
	Combo Fitting/Filter needs to be cleaned	Clean Combo fitting. See section 10 maintenance.
Print Head will not heat, "At Temperature" LED never turns on	Trident Print Engine	Check the thermal fuse and heater resistance. The thermal fuse resistance should be 0 ohms and the heater resistor should be 33-48 ohms.
	PC Board	Check the LED indicators on the board. LED4: Yellow; indicates heater is on. LED5: Green; indicates Print Head has reached its operating temperature. The operating temperature is set via a resistor in the print engine.

Pro Series 384 NP (continued)

System Symptom	Possible Cause	Operational Test Method
One or more channels will not fire after multiple Prime Cycles	Air in Print Head	Air in the Print Head is the most likely cause of missing channels. Refer to <i>Section 4: Installation, Configuring the Print Station, Priming the Print Heads</i> for bleeding procedures.
	Trident Print Engine	The piezoelectric crystals rarely fail unless the Print Head has been dropped or has sustained a severe impact. A cracked crystal will not allow the channel to fire, resulting in permanent loss of printing in the failed channel.
Ink Reservoir in Print Head does not refill, or no ink pumps out during an ACS or Auto-Prime Cycle.	Solenoids	Remove power from the Print Head. Disconnect solenoid cable harness. Purge, intake, and return solenoids are pinned on 1-2, 3-4, and 5-6, respectively. The Intake Valve controls ink into the Reservoir, and the Purge Valve controls ACS and Auto-Prime. Check the respective valve pins for resistance. An open coil should be replaced.
	PC Board	Check the LED indicators on the board. LED2: Green; indicates Print Head is requesting IDS to turn Liquid Pump on. LED9: Green; indicates Intake Solenoid Valve is open. LED8: Green; indicates Print Head Reservoir is full. LED3: Green; indicates Print Head Reservoir is low and Ink Out Timer has expired.
Print Head will not print.	PC Board	Make sure all print head cables and the print engine cable are seated at each end. Check the Test Points and LED indicators on the board. TP1: High voltage supply to driver IC (U9). The voltage level is set via a sense resistor in the print engine (40-150 VDC). LED6: Green; indicates high voltage is low.

Photosensor Sensitivity Test

This test will determine if the photosensor sensitivity is adjusted correctly for the application.



NOTE: The test object should be a sample of the actual product.

1. Place the test object approximately ¼ inch in front of photosensor; photosensor should sense object.
2. Place the test object near the center of the guide rails; photosensor should sense object.
3. Place the test object on far guide rail; photosensor should not sense object.
4. Check that objects on the far side of the conveyor do not trip the photosensor.
5. Check that color differences in product do not cause multiple photosensor trips at the farthest sensing distance.



NOTE: If the red LED on the photosensor fails to illuminate when an object is placed in front of (but not touching) it, this is an indication that the photosensor is disconnected, or the power supply or photosensor has failed.

Print Quality Troubleshooting

Problem: Minor fractures in print channels.

Possible Cause: Debris on front plate, air in channel.

Action: Run APS. Add brushes and positive air flow to minimize debris build-up.



Problem: Missing channels and channel fractures in print channels.

Possible Cause: Excessive debris on front plate, air in channel.

Action: Wipe front plate and run APS. Add brushes and positive air flow to minimize debris build-up.



Problem: Missing print channels.

Possible Cause: Air in channel.

Action: Run APS. If air cannot be removed, run a Prime Cycle per instructions in *Section 4: Installation*.



Problem: Missing bottom print channels.

Possible Cause: Ink build-up on lower orifices.

Action: Wipe front plate and run APS.

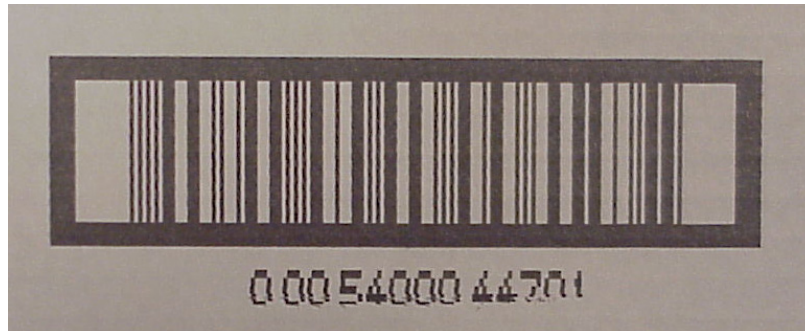

Problem: Fuzzy print.

Possible Cause: Print head too far away from substrate.

Action: Move print head to within 1/8" from product.

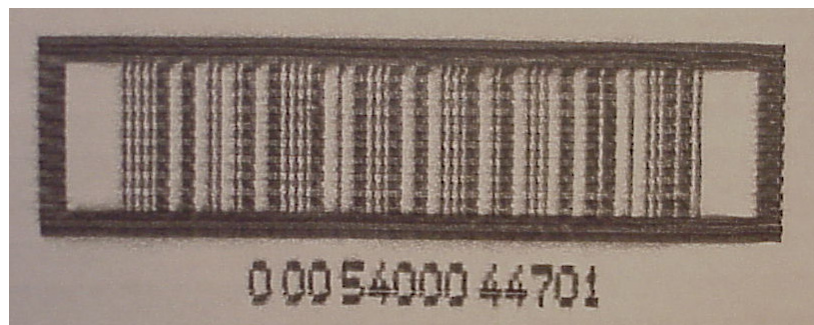

Problem: Occasional checkerboard print pattern.

Possible Cause: Encoder slipping or bouncing on belt.

Action: Tighten encoder on belt; replace encoder o-rings, if required; or replace conveyor belt with a smooth seamless belt.



Problem: Stretched out, light print, checkerboard pattern.

Possible Cause: Incorrect encoder, or incorrect line speed (set too low) if using internal encoder.

Action: Check for correct encoder.

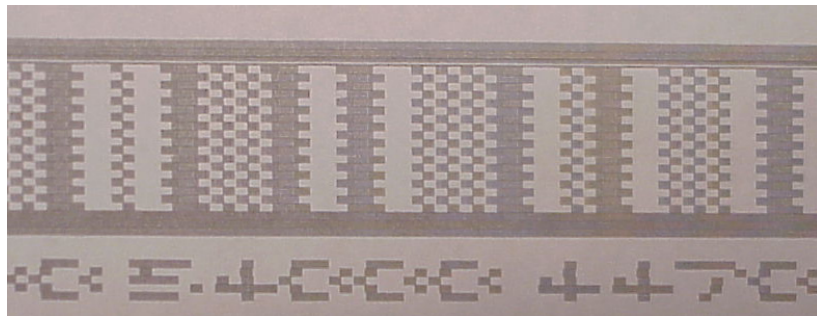

Problem: Short image, dark print, checkerboard pattern.

Possible Cause: Incorrect encoder or wheel size, or incorrect line speed (set too high) if using internal encoder.

Action: Check for correct encoder.

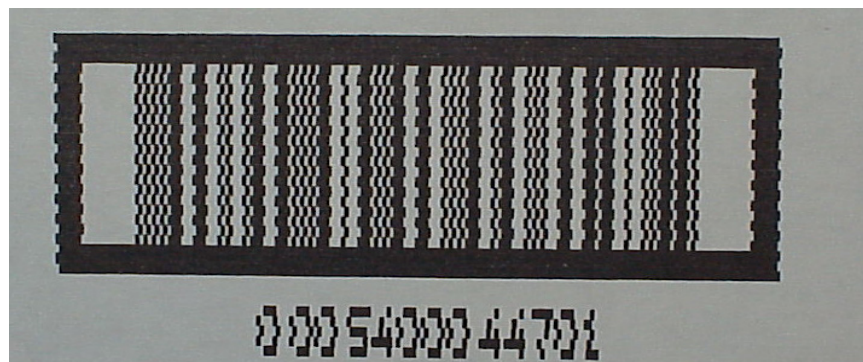

Appendix A: Specifications

Controller

Size

Height: 11" [279.4mm]
 Width: 10.39" [263.9mm]
 Depth: 3.25" [82.6mm]
 Weight: 7.4lbs (3.4kg)

User Interface

Type: Graphical User Interface
 Keyboard: 70-key, QWERTY style, elastomeric keyboard
 7" Display: 800 x 480 color LCD with touch screen, 7" diagonal

Fonts

Arial style: 9, 15, 24, 30, 48, 63, 96, and 126 standard and bold.

Storage

512 MB flash memory

Print Speed

Up to 200 fpm

Maximum Field Length

Up to 256 characters long (81 inches for variable field)

Maximum Product Length

200 inches

Maximum Repeat Print Distance

200 inches

Print Heads Supported

Two (2) ProSeries 768 Heads
 Four (4) ProSeries 384 Heads
 Four (4) ProSeries 384 NP Heads

Encoder

2400 ppr/300 ppi, TTL level, 5-26 VDC

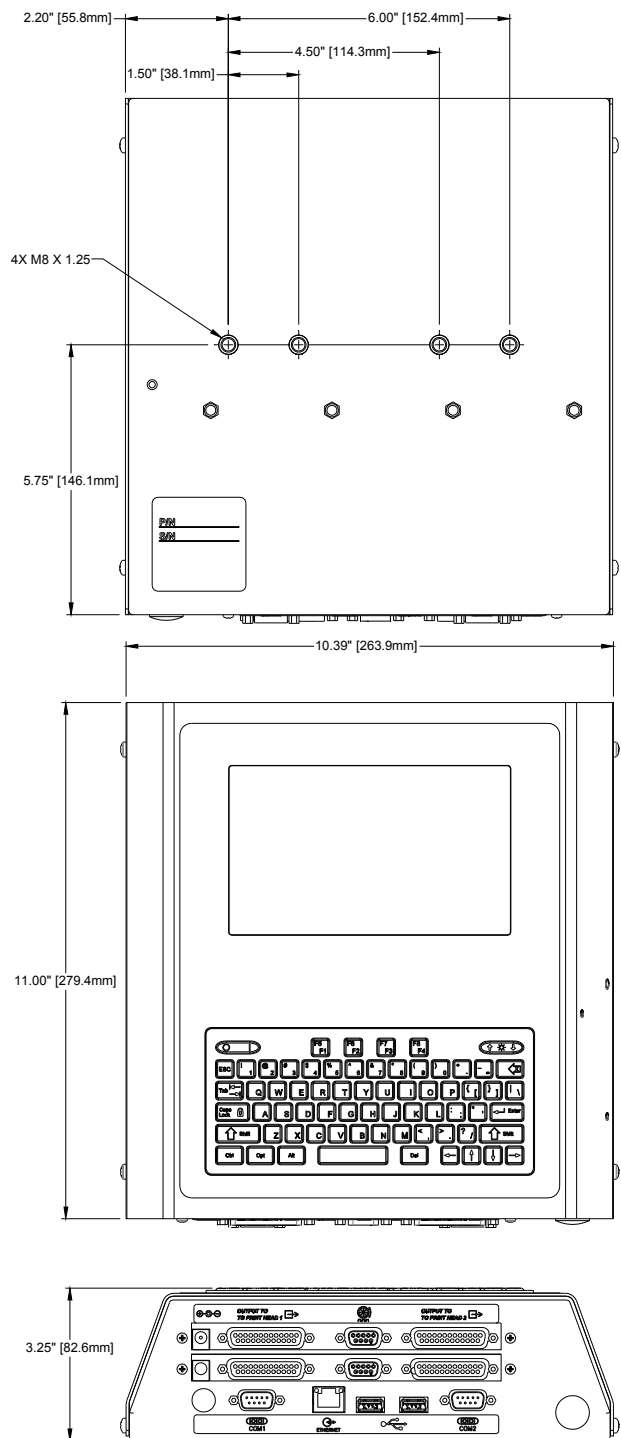

Product Sensor

24 VDC, current sinking, active low

Ports

(2) RS-232 ports, (1) 100Base-T Ethernet port

(2) USB ports

Enclosure

Stainless steel enclosure

Print Performance

Up to 10 lines of print at 200 fpm

Electrical

90-260 VAC, 50/60 Hz, 3.0A max. (power supply input)

24 VDC, 5.0A (controller input)

Environment

Ambient operating temperature: 40°F to 104°F (5°C to 40°C)

Operating humidity: 10 - 90%, non-condensing

Maximum Distance Between Print Head and Controller

25 feet

Bar Codes Supported

I 2 of 5

GTIN-14 (ITF-14)

GTIN-8 (EAN-8), GTIN-13 (EAN-13)

Code 39

GTIN-14 (UCC-128)

Code 128

GTIN-12 (UPC-A), UPC-E

Data Matrix

Print Head Specifications (Porous)

Pro Series 384 Print Head:

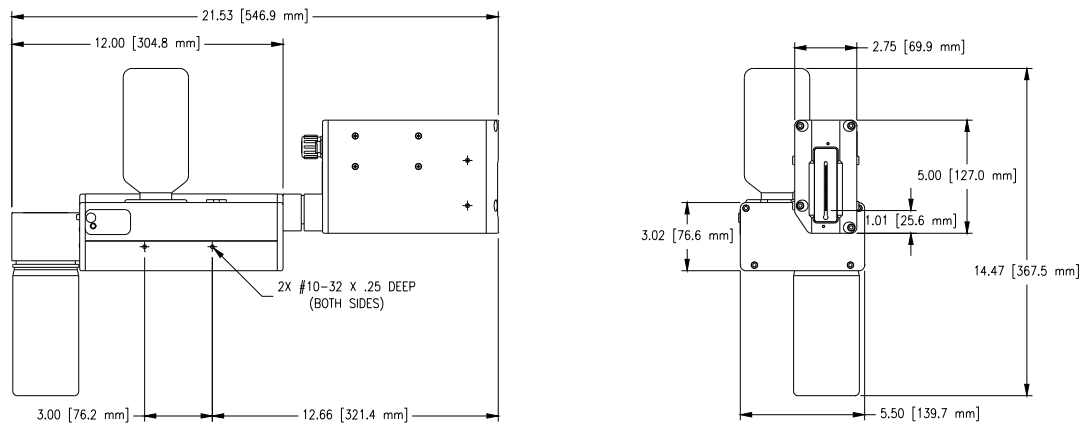

Pro Series 768 Print Head:

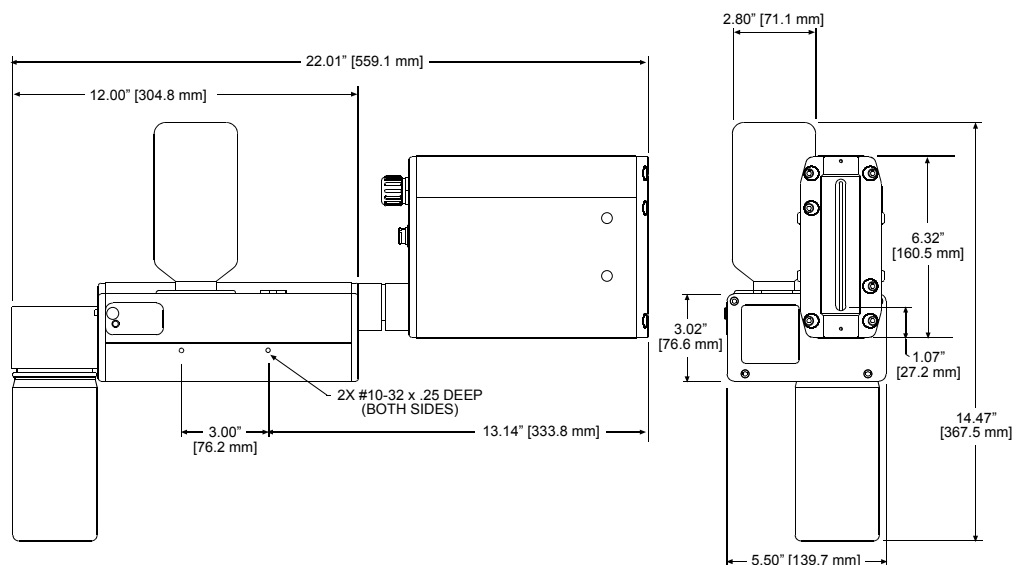

Electrical:

24VDC Input from controller

Ink System

(384 & 768 porous):

Non-pressurized capillary feed technology

Priming: Automatic Priming System

Float switch sensor: Low ink and full waste bottle detection

Ink Specifications:

ScanTrue II® (384 and 768 Print Heads),

Pigmented oil-based for porous surfaces

Technical Data:

	384 Head	768 Head
Image Area:	.38" - 2" (10 - 51mm)	.38" - 4" (10 - 102mm)
Channels:	128	256
Orifices:	384	768
Horizontal Resolution:	150 or 300 dpi	150 or 300 dpi
Lines of Print:	1 - 21	1 - 42

Operating Conditions: Temperature: 50° - 104° F (10° - 40° C)
 Relative Humidity: 20 - 80% (non-condensing)

Storage Conditions: Temperature: 32° - 109°F (0° - 43° C)
 Relative Humidity: 20 - 80% (non-condensing)

Pro Series 384NP Print Head

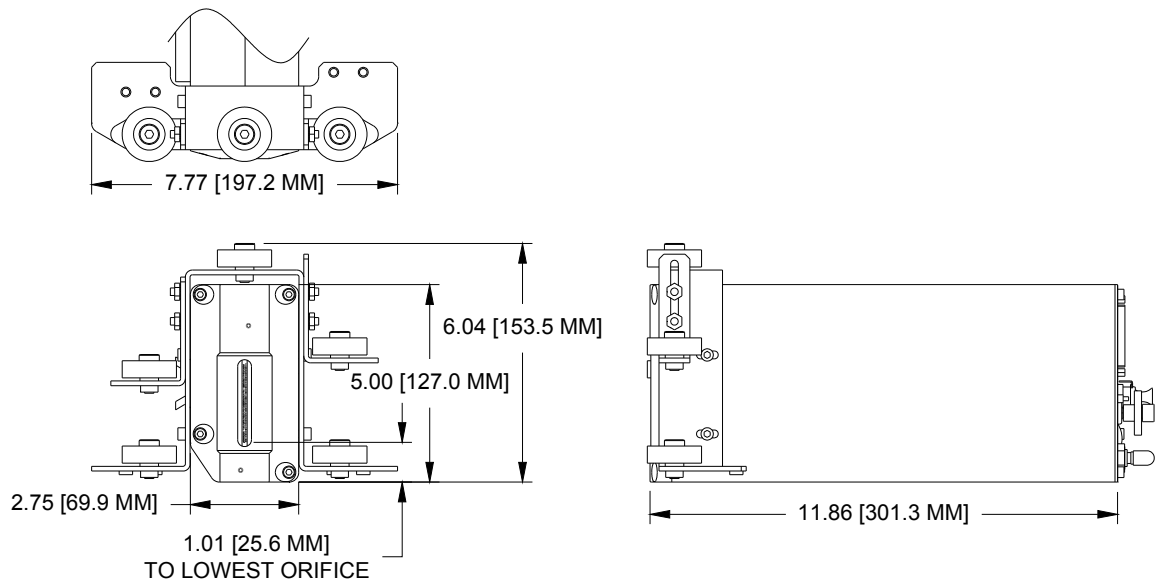

Size - IJ384 Head

L: 11.84 [300.8mm]
 W: 2.75" [69.9mm]
 H: 5.0" [127.0mm]
 Weight: 6 lbs [2.7kg]

Enclosure

Anodized aluminum

Electrical

24 VDC input from controller

Ink Filtration

25 micron in-line system inlet filter

10 micron built-in filter in print engine

Print Speed

Alpha/ Numeric Text up to 200 fpm @ 200 dpi,

125 fpm @ 300 dpi. Barcoding up to 150 fpm.

Print Resolution

384/128 Head: 128 addressable channels, 2" solid print height

768/256 Head: 256 addressable channels, 4" solid print height

Throw Distance

Up to 1/8" (1/16" recommended for consistent print quality)

Ink Type

AllWrite A5000, Dye-based Ink for Non-porous substrates, black

Environment

Ambient operating temperature: 50°F to 104°F (10°C to 40°C)

Operating humidity: 5 - 80% non-condensing

Pro Series IS

Size

Height: 22.12" [561.3mm]

Width: 14.18" [360.2mm]

Depth: 4.47" [113.5mm]

Weight: 15 lbs. [6.8 kg]

Cable and Tubing Clearance: 5" from the bottom of the enclosure

Enclosure

Sealed stainless steel industrial enclosure.

Ink Filtration

25 micron built in supply reservoir

Electrical

Non-European: 103VAC to 122VAC, 60Hz, 1.0 Amp max.

European: 207VAC to 253VAC, 50Hz, 0.5 Amp max.

Normal Operating Pressure Range

0 psi to 30 psi (approximately) pump output when operating

Cable Ports

- Communication to controller
- Power cord
- Optional ink status beacon

Environment

Ambient operating temperature: 50°F to 104°F (10°C to 40°C)

Operating humidity:

- AllWrite A5000 Ink: 5 - 80% non-condensing

Tubing Limitations

Maximum vertical tube length (bottom of Pro Series IS to bottom of highest print head) = 20 ft ink pump limitation.

Maximum height of Pro Series IS or tubing above print head= 3ft vacuum pump limitation.

(See Section 4: Installation, Plumbing the System.)

Number of Heads Allowed

2

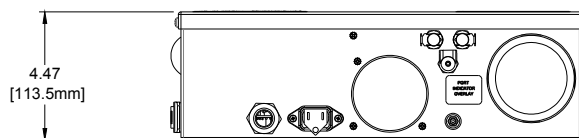
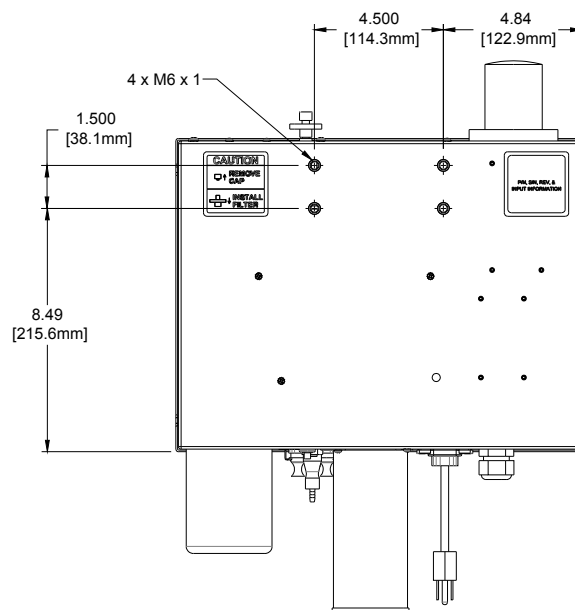
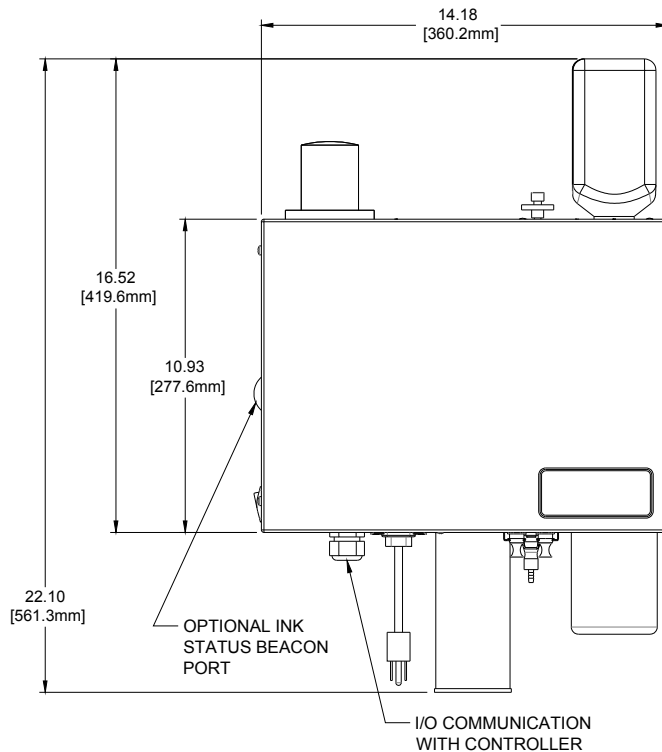

SCS (Smart Cleaning System) Photosensor

The SCS photosensor (5760-871) is similar to the print trigger photosensor but functions as an integral part of the SCS (Smart Cleaning System) by assisting with quality enhancement of the first printed image after a delay between prints. This feature is only used with 384NP Print Heads.

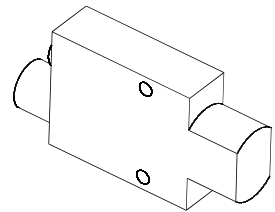

Automatic Air Knife

The air knife system is an optional device used to expedite drying on non-porous applications. Although results vary with application, 10% - 30% of the dry time is typical when compared to without the air knife. Mounting bracketry for the side of a conveyor is included. The air knife is sold as a single side or dual side device. When ordering for dual side application, order one each of both the single and dual side part numbers. An external photocell initiates drying by detecting the leading edge of the product. The automatic air knife control has an adjustable timer from .1 sec to 99 sec.

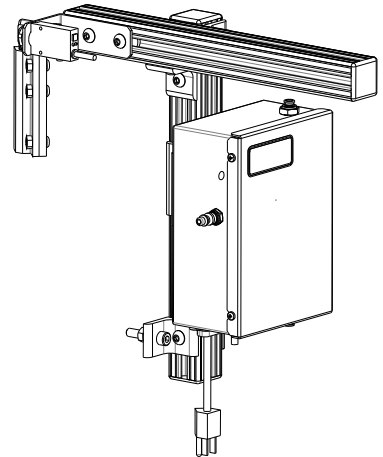

Ink

Ink is supplied via 500 mL or 1 liter plastic containers. Ink types include ScanTrue® II pigmented ink for high edge definition porous substrate and AllWrite A5000 non-porous surfaces or special coated cartons.



NOTE: Never mix ink types because they are not miscible. Irreversible internal damage will occur.

Waste Bottle

The APS includes a Waste Collection Bottle mounted on the rear of the Print Head assembly. This bottle must be changed when full to prevent improper operation of the system. Instructions for waste disposal are on the collection bottle.

Encoder

The Marksman® Duo HR System uses a 2400 ppr open collector output encoder. The wheel is sized to provide the correct timing inputs to allow the print heads to print 100, 200 and 300 dpi.

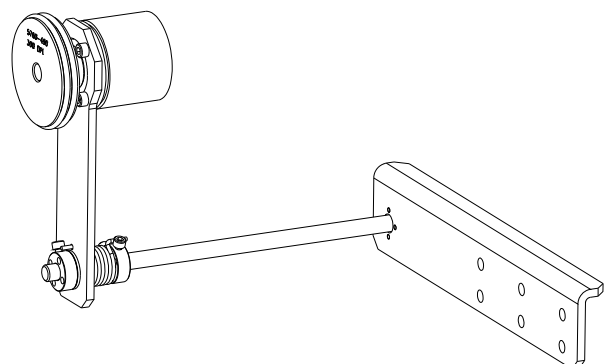

Encoder Pin Out for NP & Pro Series Interface Boards

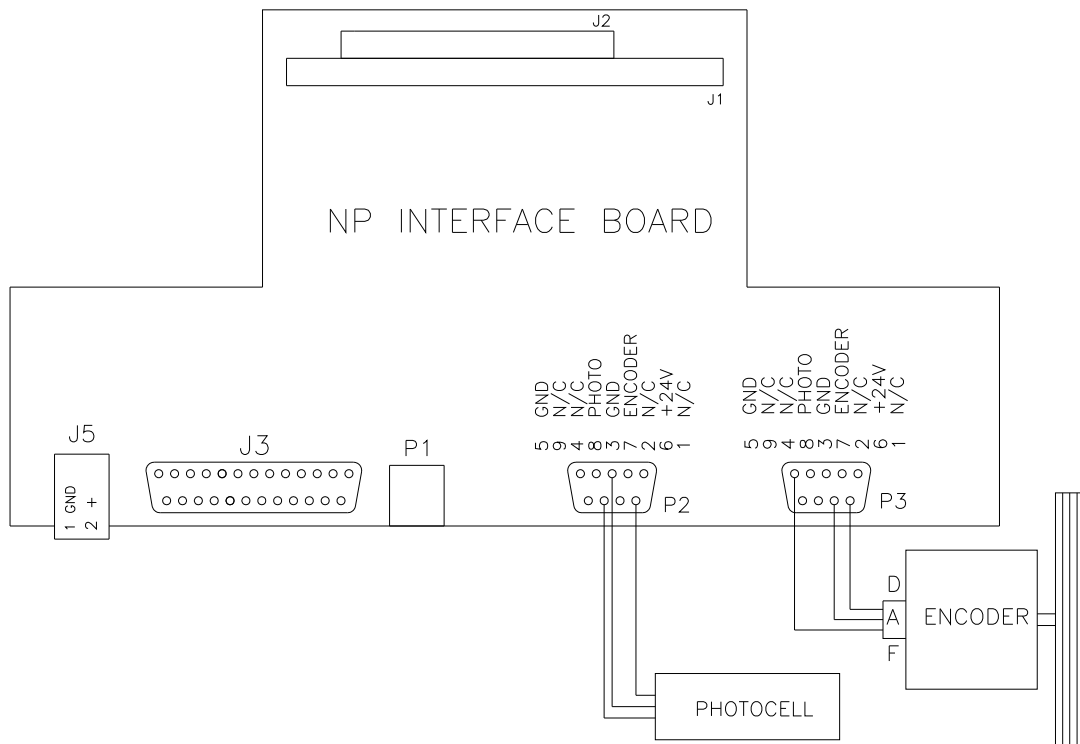
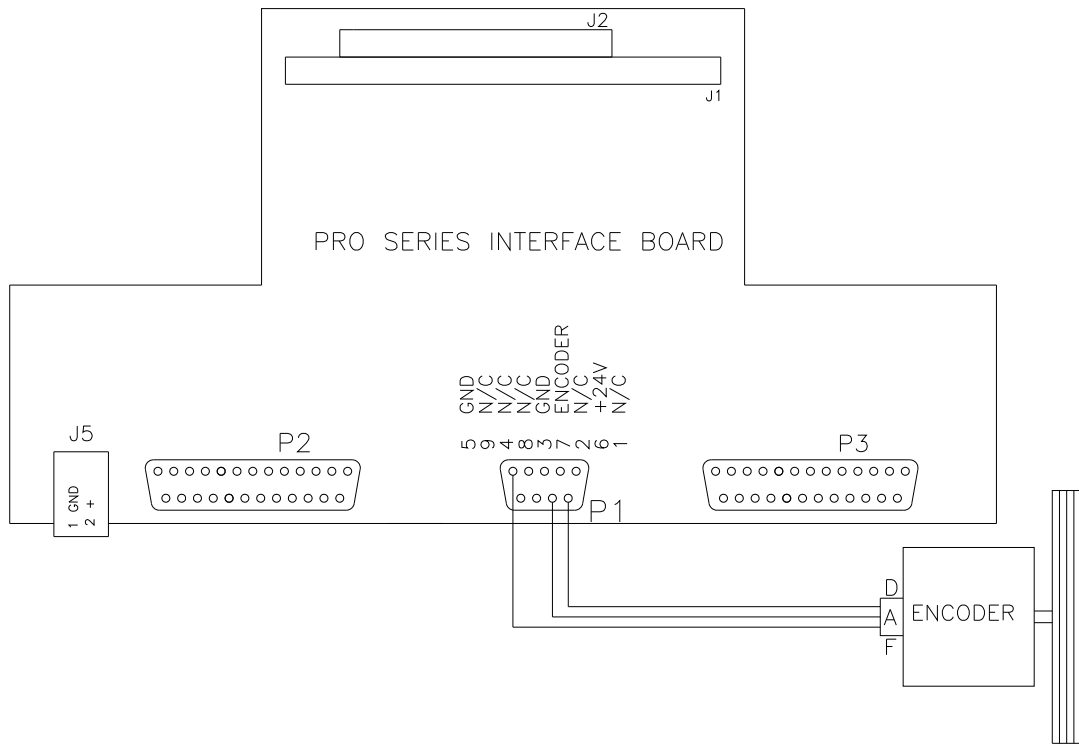

Pro Series IS

System Features

1. *Centralized ink delivery.* Ink is pumped from one location through a single tubing line that is subsequently teed downstream to all print heads in the system. As the print heads demand more ink, the liquid pump delivers ink to the requesting print head. Although the ink line is pressurized, a print head will not receive the ink unless its intake solenoid is opened. Each print head controls its own ink level in its own reservoir.
2. *Ink supply "low" detection.* When the Pro Series IS detects ink low via the float in the ink reservoir, it disables the ink pump, leaving a safe amount of ink. The Pro Series IS then alerts the operator by turning on the attached beacon light, and by sending a signal via I/O to the controller.
3. *Ink supply "out" detection.* If the ink supply bottle is not replaced in a timely fashion, the next time that a print head requests ink, a timer in the print head will start. If the ink supply has not been replaced within five minutes, print will be disabled on all print heads, and a signal will be sent to the Pro Series IS that will cause a slow flashing of the beacon.
4. *Centralized vacuum and ink waste collector.* Like the centralized ink, vacuum is supplied to all the print heads via a single tubing line that is subsequently teed. The Pro Series IS is equipped standard with a heavy-duty vacuum pump to assist in the Automatic Cleaning System (ACS). Additionally, it will assist in the removal of waste ink while bleeding the tubing.
5. *AFS (Automatic Flushing System):* A solvent can is screwed into a receiver. This fluid then passes through a regulator. A pressure sensor detects when the can's liquid level is low. The pcb then signals the beacon to illuminate steady. The solvent exits the Pro Series IS through a third tubing line. Like the ink and vacuum tubing lines, the solvent line is connected to the rear of the print head. A solvent solenoid inside the print head controls the flow of solvent on its way to supplying fresh cleaning fluid for ACS enhancement. The excess solvent and ink used during the ACS cycle is vacuumed off and returned to the Pro Series IS waste collection system.
6. *Ink capacity.* Both the 500 mL and 1 L bottles are accommodated by the Pro Series IS.
7. *Safety.* The on-board microcontroller will prevent an excessive duty cycle on the liquid pump. It also disables the liquid pump when ink is low, and both pumps when any ink anomaly is encountered such as ink out or ink faults.

Startup Operation

After all plumbing and electrical connections have been made, toggling the power switch will initiate the Pro Series IS. The system only responds to input from the I/O connection to the Controller. This I/O connection is essentially a pass through connection to the print head bus. In other words, the print heads control the ink pump and vacuum pump on/off states. If the print heads are not requesting ink for reservoir refill or vacuum from an ACS cycle, then the Pro Series IS will remain idle.

Appendix B: Parts and Supplies

Controller Battery

Type: CR1220, 3V (available at department and electronics stores).



CAUTION: There is the danger of explosion if the battery is incorrectly replaced. Replace only with the same or equivalent type recommended by the manufacturer. Dispose of used batteries according to the manufacturer's instructions.



ATTENTION: Il y a danger d'explosion s'il y a remplacement incorrect de la batterie. Remplacer uniquement avec une batterie du même type ou d'un type équivalent recommandé par le constructeur. Mettre au rebut les batteries usagées conformément aux instructions du fabricant.

Replacing the Battery

1. Go to the **Home Screen**.
2. Cancel any currently printing messages; save the product counts, if applicable.
3. Remove power from the controller by unplugging the power supply from all print head interface boards.
4. Remove and replace the battery on the CPU board.
5. Reapply power to the print head interface boards and wait for the Home Screen to become visible. If the Home Screen does not appear after a few minutes, press the **ON** button on the keyboard.
6. Recalibrate the touch screen.
 - a. If, after the Home Screen is displayed, a dialog box appears that says preventive maintenance is overdue, press the **Enter** key on the keyboard. **DO NOT** touch the **OK** button on the dialog box.
 - b. Press the spacebar on the keyboard to display the Home Screen buttons.
 - c. Press the 'T' key on the keyboard to display the Touch Screen Calibration Screen.
7. Set the time and date.
8. Restore system defaults.
9. Repeat Step 6.
10. Reset the total product counts.
11. Reset the Preventive Maintenance Timer.
12. Reload the message, if any, that was printing before the battery was replaced.

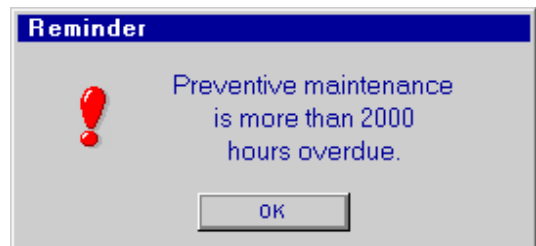

Controller Assembly Kits

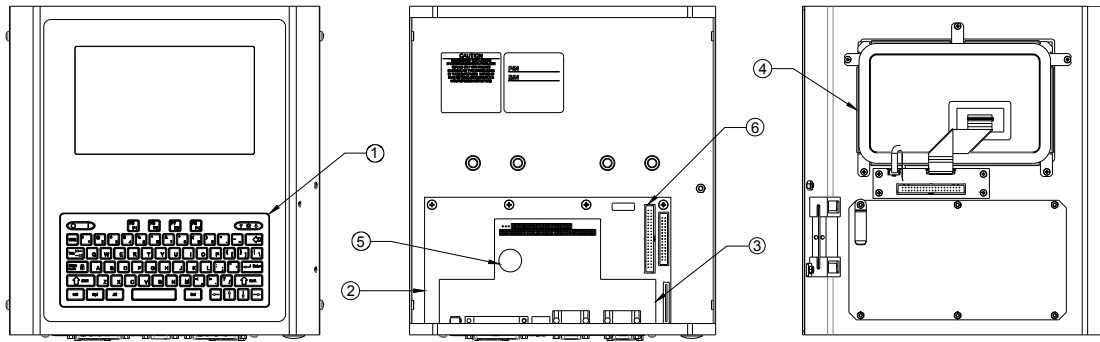

ITEM	PART NO.	DESCRIPTION
1	5765-201	Keypad Replacement Kit
2	5765-214	CPU PCB Replacement Kit
3A	5765-204	Interface PCB Kit, Pro-Series
3B	5765-219	Interface PCB Kit, 384 NP
4	5765-215	Display Replacement Kit, 7", with Touch Screen Controller
5		CPU Battery (Type: CR1220)
6	5760-746	Cable, Display to CPU PCB, 40 Conductor
(not shown)	5760-333	24 VDC Power Supply Kit

Consumables

Part No.	Description	Type	Color	Size
001-0598-01F	ScanTrue® II	Pigmented Oil Based for Porous Media	Black	500mL
001-0921-01	AllWrite A5000	Dye-Based For Non-Porous Media	Black	500mL

Print Head Cleaning

PART NO.	DESCRIPTION	CONTENTS
5760-695	Maintenance Spray for ScanTrue® II	2 Pack
5760-832	Sponge Swabs	100 Sponge Swabs
5760-860	Cleaning Solution for AllWrite A5000	2 Pack
5760-861	Maintenance Spray for AllWrite A5000	2 Pack
X30001-001	Print Head Wiping Cloth	300 pack

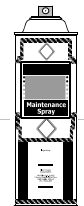

Print System Service Kits

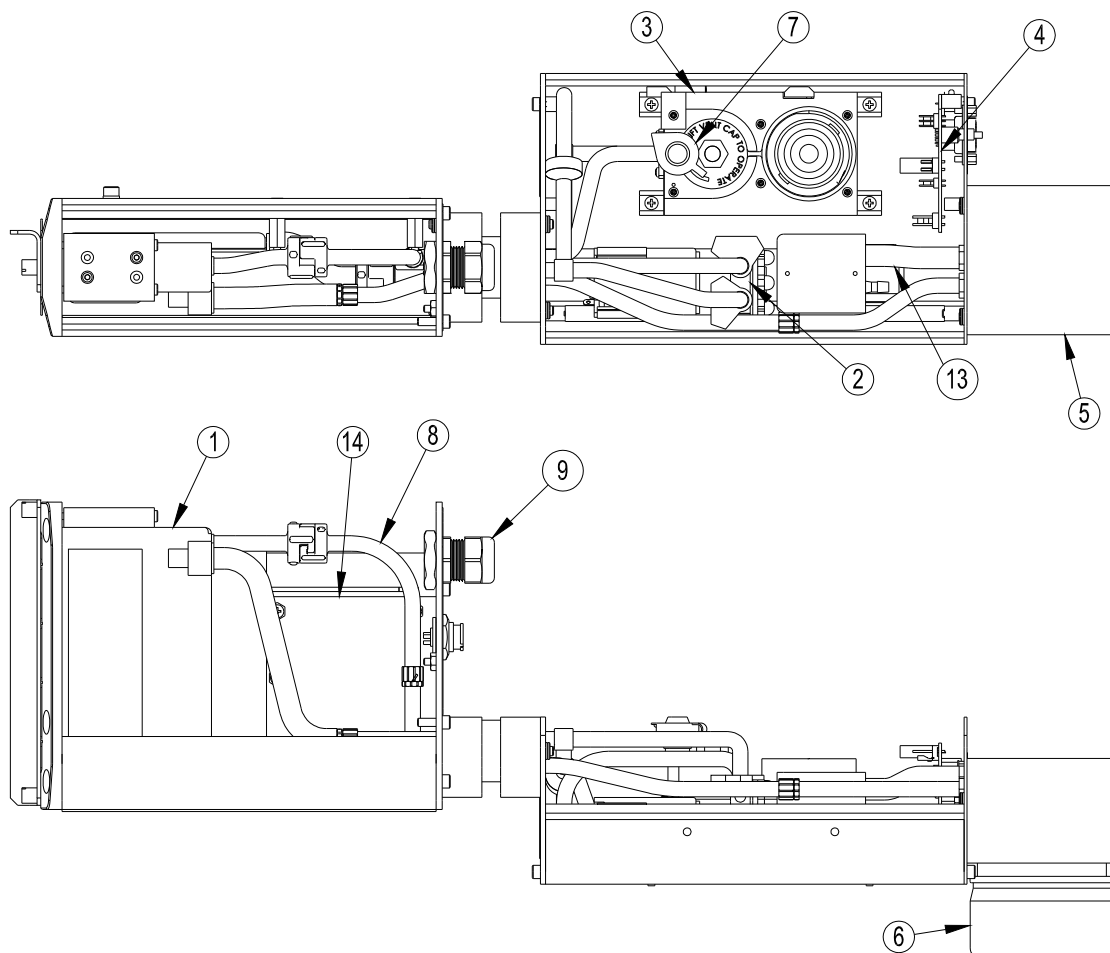

Item No.	Part No.	Description
1	2464632	Print Engine Kit, 384, ScanTrue II, APS, W/Tubing & Nose Piece
1	2464613	Print Engine Kit, 768, ScanTrue II, APS, W/Tubing & Nose Piece
2	2464614	Prime Pump Replacement Kit
3 & 8	2464616	Reservoir & Ink Line Tubing Replacment Kits, ScanTrue II
4	2464617	APS PCB Replacement Kit
5	2464618	Ink Separator Replacement Kit
6	2464620	Ink Waste Bottle Kit, ScanTrue II (4 Pack)
7	X40119-001	Vent, Filter Replacement (1 Per)
9	2464120	Communications Cable
10	2464144	Cable, Driver Board to APS PCB
11	5760527	Cable, Reservoir to APS PCB
12	2464146	Cable, Prime Pump to APS PCB
13	2464147	Cable, Vacuum Pump to APS PCB
14	2464629	HV PCB Replacement Kit, 384 and 768 heads only (Not Shown)

Pro Series 384NP Print Head (Non-Porous):

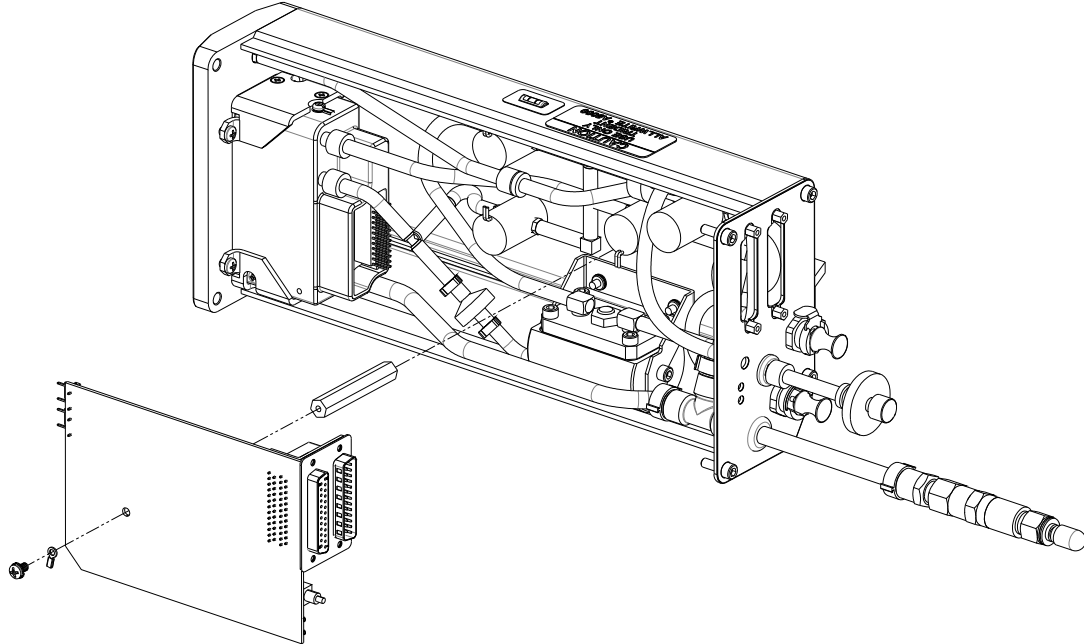

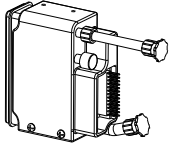
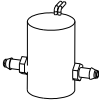
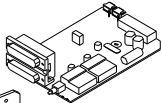
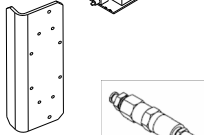
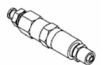
ITEM	PART NO.	DESCRIPTION	CONTENTS	
1	5760-866	384NP Print Engine Replacement, AllWrite A5000	Print engine 5765-516 - 1; Gasket 5760-686 - 1; Screw, M3 x 8, 5101-601 - 4; Screw, #6-32 x 3/8, 5151-126 - 4	
2	5760-347	Solenoid Replacement	Solenoid w/crimp pins 5760-611 - 1; Fitting, 10-32 to 1/8 barb, SS, 1902-260 - 2; Screw, #2-56 x 1/4, 5101-001 - 2	
3	5760-386	Print Head PCB Replacement	PCB 5760-523 - 1	
not shown	5760-807	384NP Orifice Cover Plate	Orifice cover plate assembly 5760-690 - 1	
4	5765-220*	Combo Fitting/Filter	Combo Fitting/Filter 5765-528 - 1	
5	5760-867	Non-porous 384NP Internal Tubing and Fitting Replacement	Viton and Bev-A-Line tubing, 1/8 ID and 3/16 ID; Fitting 1900-758 - 2; Fitting 1902-260 - 10; Fitting 2460-120 - 6; Fitting 2460-141 - 1; Fitting 2460-143 - 1; Fitting 2460-144 - 1; Fitting 2460-145 - 1; Fitting 2460-159 - 1; Fitting 5361-307 - 2; Fitting 5361-321 - 2; Fitting 5361-322 - 2; Fitting 5361-323 - 4; Fitting 5361-359 - 1; Fitting 5361-317 - 1; Safety Clip 5361-360 - 4; Grommet 5765-527 - 1 Fitting 5361-326 - 1; Check valve 2460-165 - 1; Filter 5760-629 - 1; Hose clamp 2460-166 - 2; Combo Fitting/Filter 5765-528 - 1 Orifice .01" 5361-308 - 1	



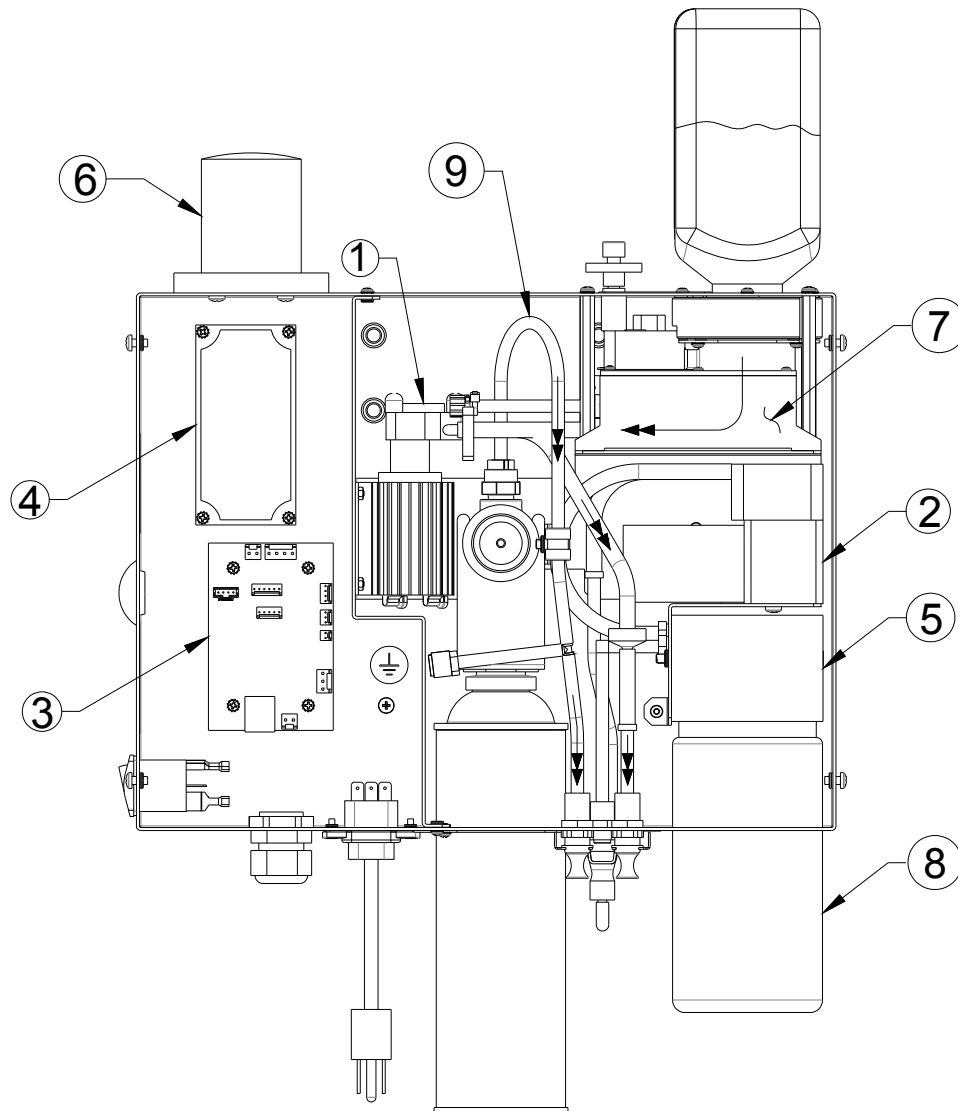

* Combo Filter is cleanable; refer to the *Annual Print head Maintenance Section*

Pro Series IS Assembly Kits

Pro Series IS

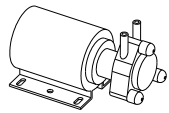
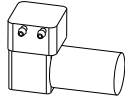
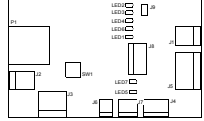
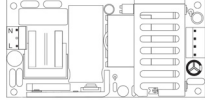
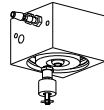

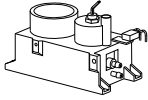
ITEM	PART NO.	DESCRIPTION
1	5760-335	Liquid Pump Replacement
2	5760-336	Vacuum Pump Replacement
3	5760-337	PCB Replacement
4	5760-338	Power Supply Replacement
5	5760-340	Separator Replacement
6	5760-372	Beacon Replacement
7	5760-868	Reservoir Replacement, AllWrite A5000
8	5760-869	Waste Bottle Replacement, AllWrite A5000 (2 Pack)
9	5760-870	Internal Tubing & Fitting Replacement, Flushing
<i>See next page for kit contents and drawings</i>		

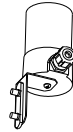
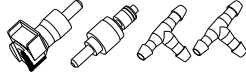
ITEM	PART NO.	DESCRIPTION	CONTENTS	
1	5760-335	Liquid Pump Replacement	Liquid pump 2460-230 - 1; Hose clamp 5760-519 - 2	
2	5760-336	Vacuum Pump Replacement	Vacuum pump 5760-516 - 1	
3	5760-337	PCB Replacement	PCB 5765-520 - 1	
4	5760-338	Power Supply Replacement	Power supply 5760-507 - 1	
5	5760-340	Separator Replacement	Separator 5760-526 - 1; Screw 5151-001 - 2	
6	5760-372	Beacon Replacement	Beacon 5760-511 - 1	
7	5760-868	Reservoir Replacement, A5000	Reservoir X4017-001	
8	5760-869	AllWrite A5000	Waste Bottle 5760-543-2	
9	5760-870	Internal Tubing & Fitting Replacement	Tubing, 1/8 ID, 1301-468; Tubing, 3/16 ID, 1301-871; Tubing, 1/4 ID, 1301875; Tubing, 3/8 ID, 1303-559; Fitting 5361-338 - 2; Safety Clip 5770-334- 1 Fitting 1900-758 - 2; Fitting 2460-141 - 1; Fitting 2460-144 - 1; Fitting 2460-145 - 1; Fitting 5361-307 - 1; Fitting 5361-310 - 1; Fitting 5361-318 - 1; Fitting 5361-317 - 2; Hose Clamp 5765-442-1 Filter 2460-159 - 1; Check valve X40081-001 - 1; Hose clamp 5760-519 - 2, Safety clip 5770-333-1	
not shown	5760-345	Optional Remote Beacon	Beacon 5760-520 - 1; Strain relief 5760-222 - 1; Mounting bracket 5760-234 - 1; Screw, 10-32, 5151-121 - 1; Screw, 5/16-18, 5082-001 - 2; T-nut, double 5760-405 - 1	
not shown	5760-344	External Fitting Kit	Fitting 1900-405 - 1; Fitting 5361-329 - 1; Fitting 2460-120 - 2	
not shown	5760-341	Replacement Bulb Kit, 12 VDC	Bulb 2470-142 - 2	

Encoder Replacement Part Kit

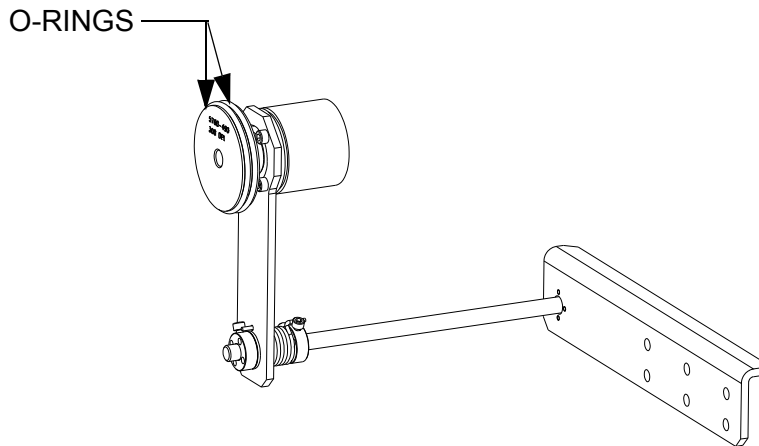

PART NO.	DESCRIPTION	CONTENTS
5765-206	Encoder O-Ring Replacement Kit	O-ring, 2-7/8 ID x 3-1/8 OD x 1/8 W - 3; O-ring, 4-7/8 ID x 1/8 W - 3; O-ring, 2.175 ID x .103 W - 2

Roller Replacement Part Kit

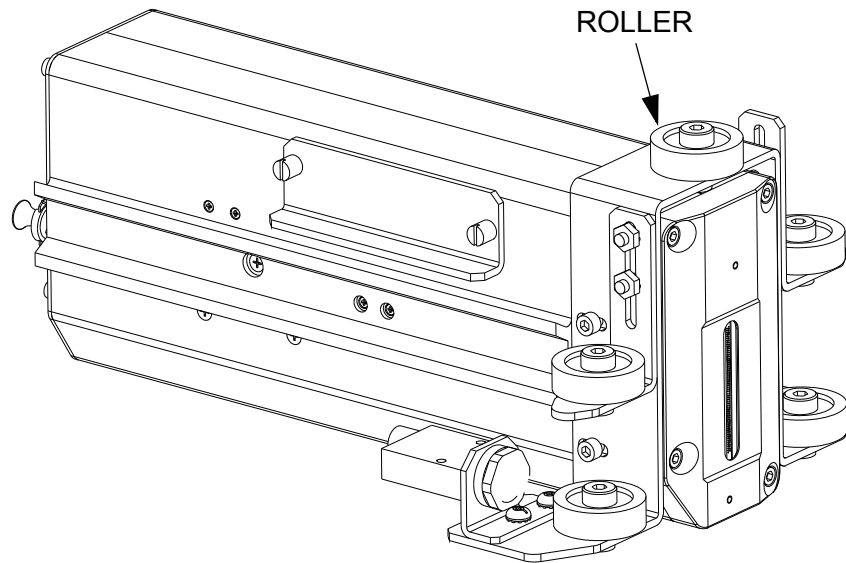

PART NO.	DESCRIPTION	CONTENTS
5760-835	Roller Replacement Kit	Roller 5760-476 - 5
5760-815	Roller Bracket Alignment Kit	Roller Bracket Alignment Tool - 1

Fittings and Tubing

PART NO.	DESCRIPTION	CONTENTS	WHERE USED
1301-468	Tubing, 1/8" ID x 1/4" OD	50 foot roll	External plumbing of Non-Porous Systems.
5770-224	Fitting 1301-699, 1/8 Barb x 1/8 Barb In-Line Shut-off Valve	5 fittings per kit	Effluent bottle
5765-207	Fitting 5361-338, 1/8 Barb x 1/8 Flow Bulk-Head Male Valve	5 fittings per kit	Vacuum port on rear of print head and bottom of Pro Series IS
5765-208	Fitting 5361-329, 1/8 Barb x 1/8 Flow In-Line Male	5 fittings per kit	Connects to print head ink port and Pro Series IS ink port, or any female fitting
5770-226	Fitting 1900-405, 1/8 Barb x 1/8 Flow In-Line Female Valve	5 fittings per kit	Connects to print head vacuum port and Pro Series IS vacuum port, or any male fitting
5765-209	Fitting 2460-120, 1/8 Barbed Tee	5 fittings per kit	Ink and vacuum supply lines
5765-210	Fitting 2460-143, Luer Cap, Male	5 fittings per kit	Cap for vent ports on the print head and Pro Series IS.
5760-373	Filter 2460-159, Luer, 74 Micron	5 filters per kit	Vent port on back of print head and top of Pro Series IS.

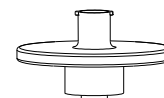
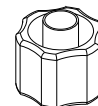
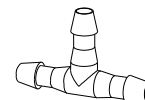
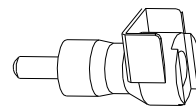
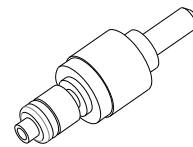
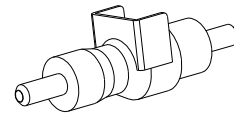
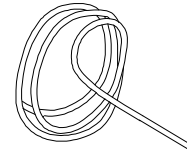

Appendix C: Performance Parameters

The performance of a Controller is limited by the DPI setting and the sum of the maximum field stacks on each side of a message. The maximum field stack for a side is defined as the maximum number of vertically aligned fields. In the following example, Task1:Side1 has a maximum field stack of three fields and Task1:Side2 has a maximum field stack of two fields. Thus, the sum of the maximum field stacks for Task1 is five fields.

$(\text{Task1:Side1}) + (\text{Task1:Side2}) = 3 + 2 = 5 \text{ fields}$

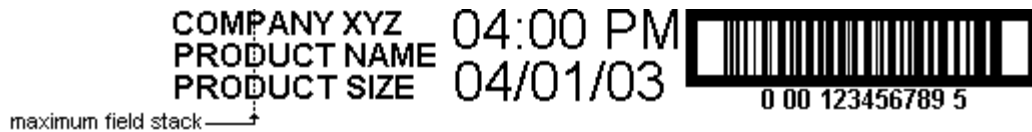

Task1:Side1

If Task1 and Task2 are printing this same message, the sum of the maximum field stacks of Task1 and Task2 is ten Fields. thus, the maximum field stack the controller has to process is ten fields.

$(\text{Task1}) + (\text{Task2}) = 5 + 5 = 10 \text{ Fields}$

The absolute maximum line speed for a task is 200 ft/min. The following table can be used to determine the maximum line speed of a controller given a maximum field stack and dpi.

Maximum Field Stack of Controller	Max. Line Speed @ 100 dpi (ft/min)	Max. Line Speed @ 150 dpi (ft/min)	Max. Line Speed @ 200 dpi (ft/min)
10 or less	200	200	200
11	200	200	181
12	200	200	166
13	200	200	153
14	200	190	142
15	200	177	133
16	200	166	125
17	200	156	117
18	200	148	111
19	200	140	105
20	200	133	100

The Duo Print Head operational through-put (the maximum print speed) is determined by the density and resolution of the printed message. The print density is defined as the amount of printed dots in a given area, with a solid black image having a density of 100%. The higher the density, the higher the ink flow demand is in the print head. A typical alphanumeric message has a print density of about 20%, while a 100% magnification I- 2 of 5 bar code, has a print density of about 40%. A full-scale logo with a heavy background can have a density of up to 70%. The following tables identify the image rate versus print speed for various densities. The data shown is based on a 6" message printing at 200 dpi horizontal resolution.

Line Speed (fpm)	20% - 40% Density # of Images per Sec.	Above 70% Density # of Images per Sec.
50	2	2
100	2	2
150	2	1
200	2	1

Appendix D: Communicate with Controller Via PC

This appendix has instructions for setting the IP address and subnet mask of the PC so it can communicate with the Marksman Duo XT Controller. Included are instructions for Windows 7® and Windows XP®.

Windows 7®

1. Open the **Start** menu; select **Control Panel**, then **Network and Sharing Center**.

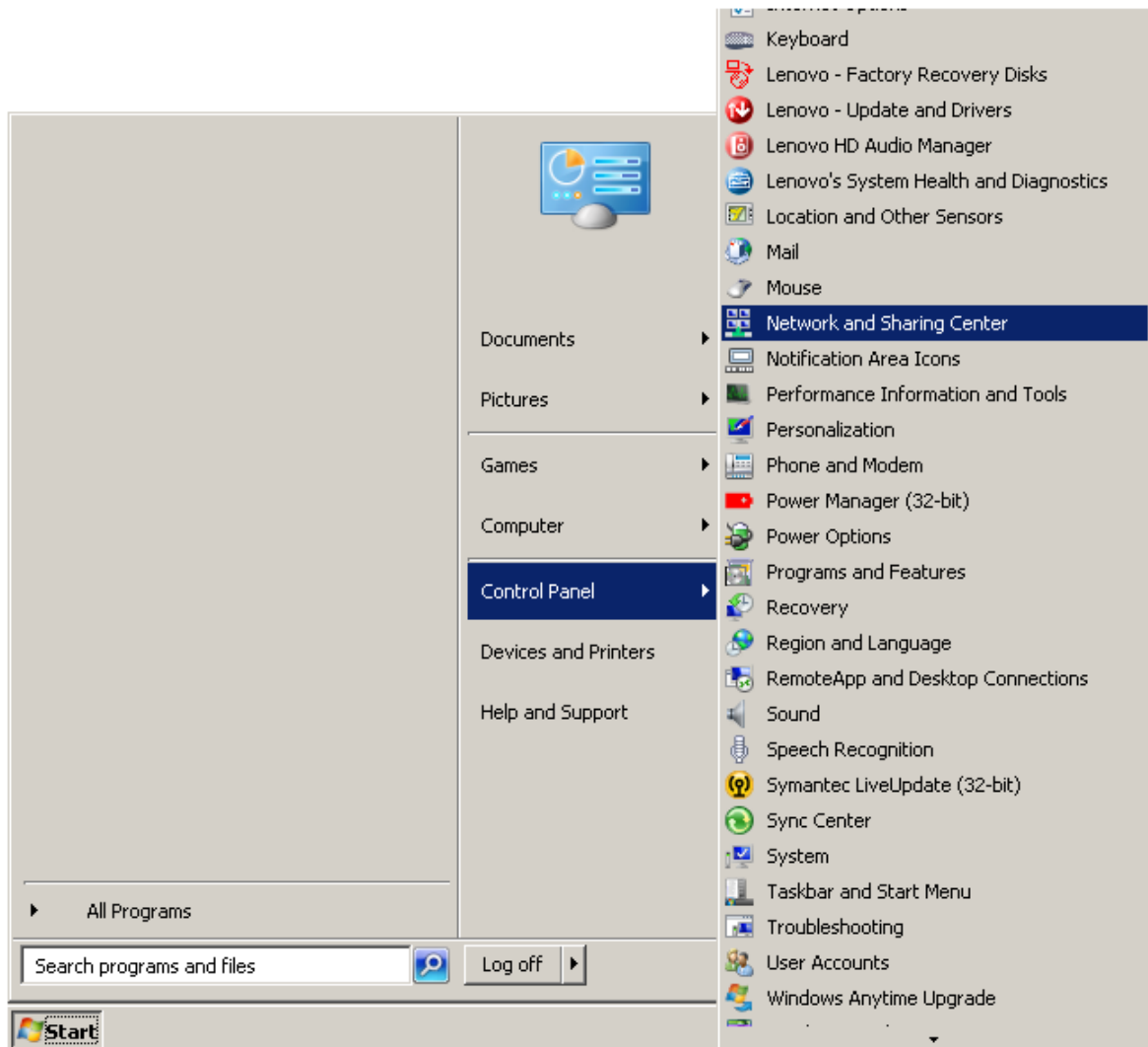

2. In the Network and Sharing Center window click on the **Local Area Connection** link for the desired network.

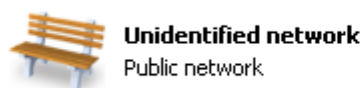

Access type: No Internet access
 Connections:  [Local Area Connection 2](#)

3. On the **Local Area Connection Status** dialog box click the **Properties** button.

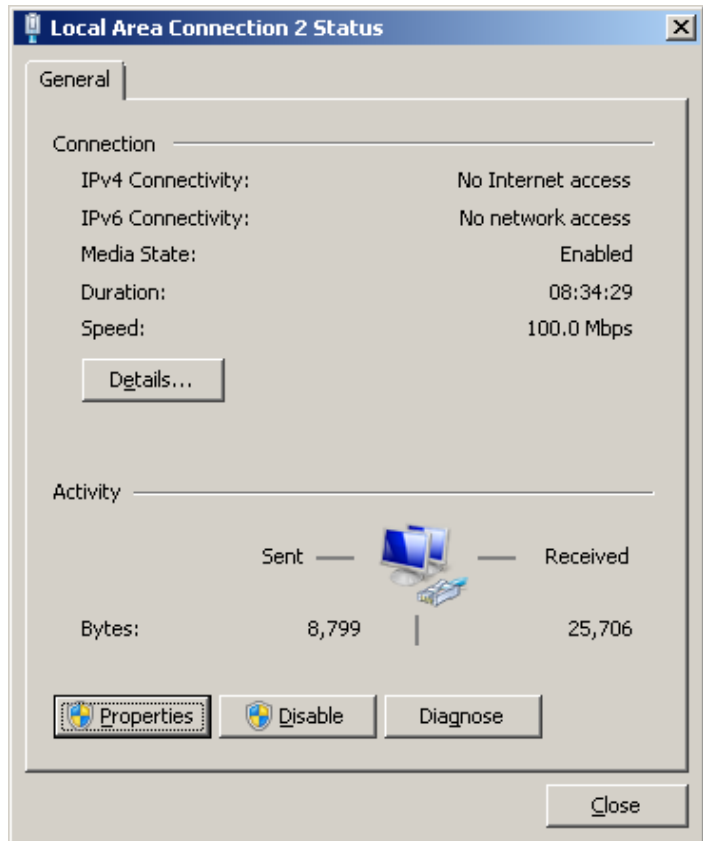

4. On the **Local Area Connection Properties** dialog box select **Internet Protocol Version 4 (TCP/IPv4)**, and then click the **Properties** button.

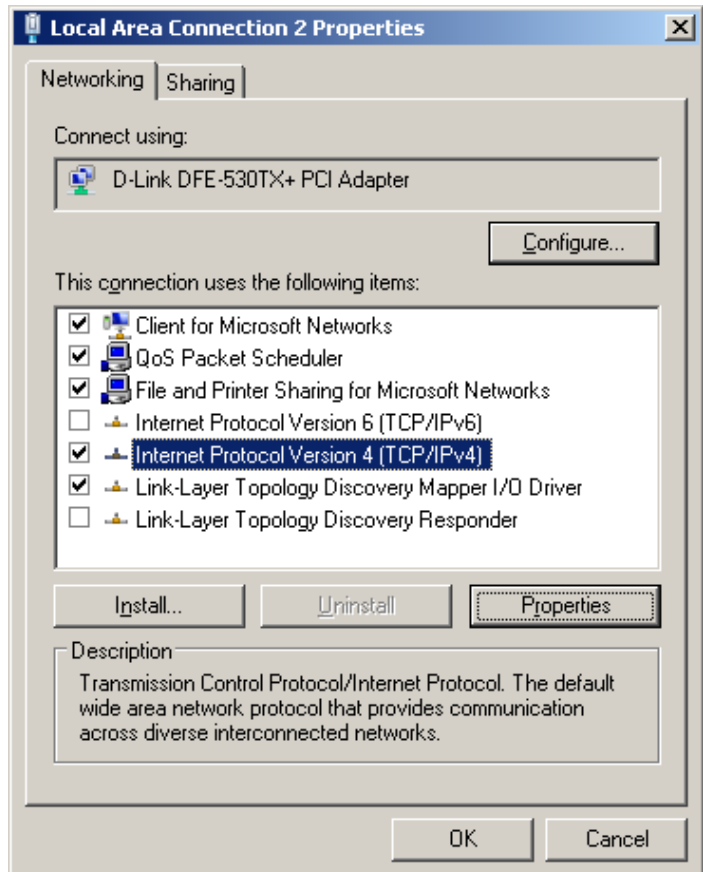

5. On the **Internet Protocol Version 4 Properties** dialog box select the **Use the following IP address** radio button, and then enter an IP address of 10.1.2.4, and a subnet mask of 255.255.255.0 and click the **OK** button.
6. Close all open dialog boxes by clicking their **CLOSE** buttons.

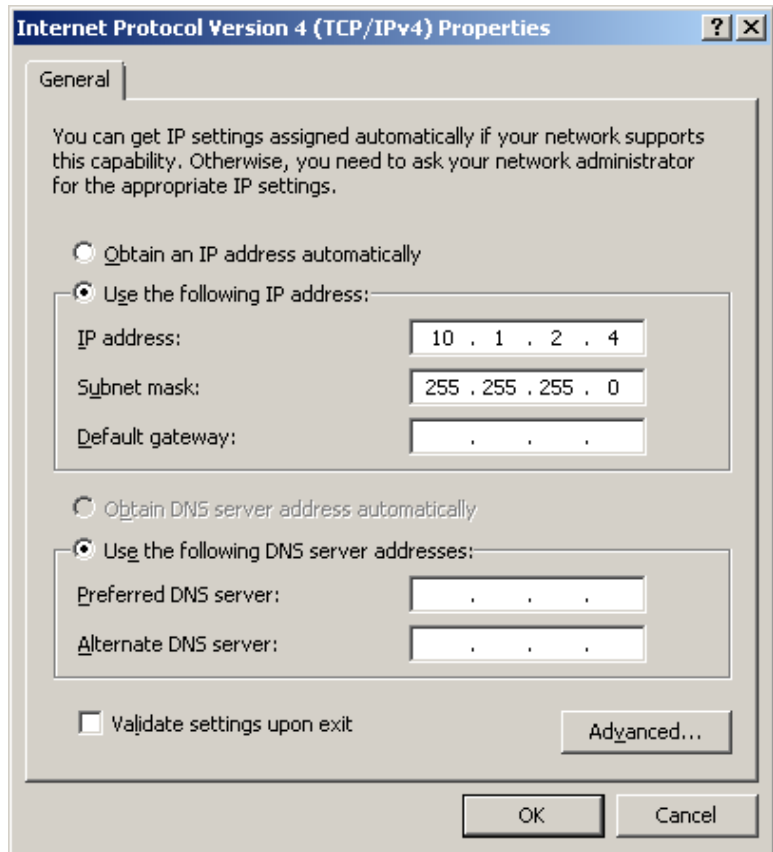

Windows XP®

1. Open the **Start** menu; select **Settings**, then **Network Connections**.

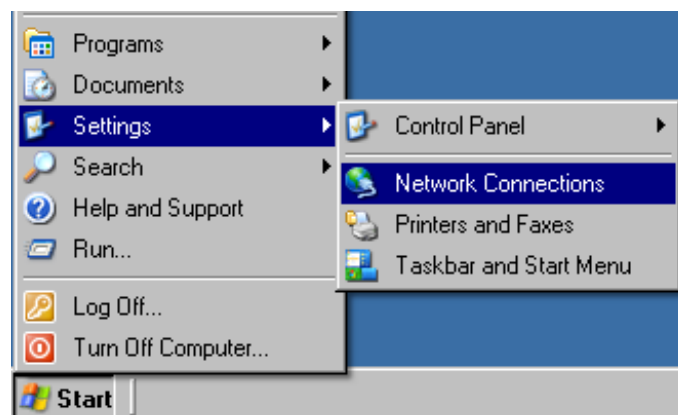

2. Click **Local Area Connection**, then open the **File** menu and select **Properties**.

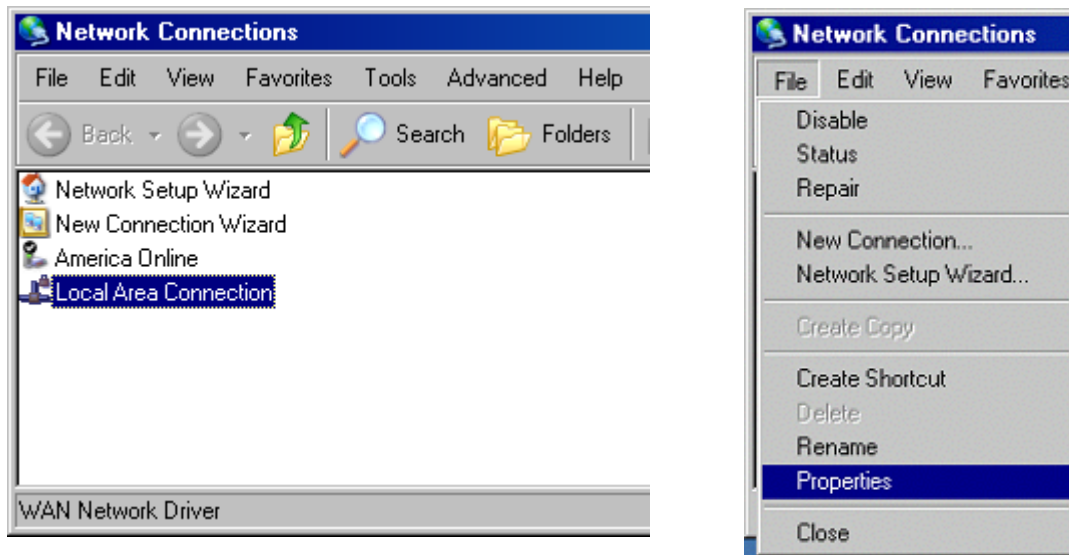

3. Select **Internet Protocol (TCP/IP)** then click the **Properties** button.

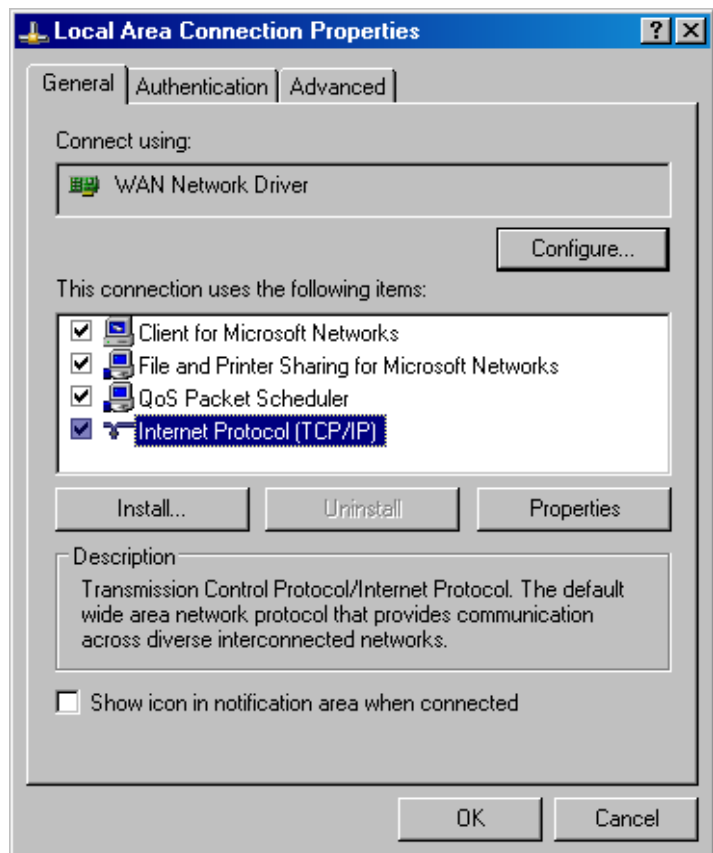

4. Click the **Use the following IP address** radio button. Enter an IP address of **10.1.2.4**, a subnet mask of **255.255.255.0**, and click the **OK** button.
5. Close the **Local Area Connection Properties** dialog box by clicking its **CLOSE** button.

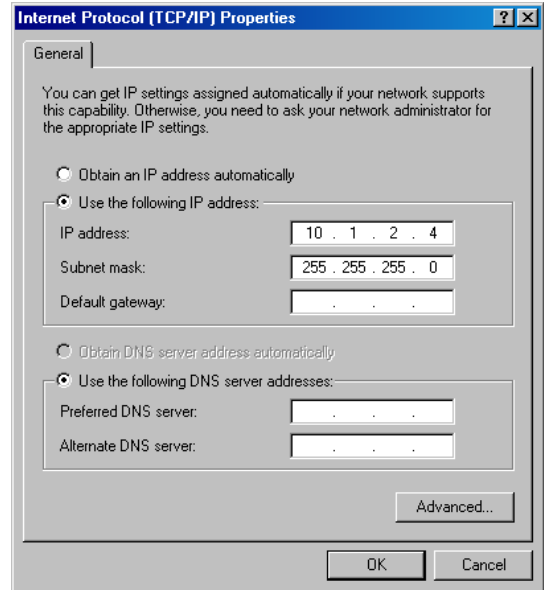

Use these procedures for making archival copies of the system configuration and print message files, and for preserving the system's configuration and print messages during firmware upgrades. File types saved during a backup are .cfg, .prd, .bmp and .alp. These are the system configuration files, message files, logo files and label files, respectively.

These instructions assume the Controller is already connected, via Ethernet, to a PC. If not, please refer to *"Appendix D: Communicate with Controller Via PC"* on page 96.

Obtain IP Address:

1. Obtain the controller's IP address. Most controllers have an IP address of **10.1.2.3**. It may be different if the controller is networked with other systems or other devices. If the IP address is unknown, go to the controller, and from the **Home Screen**:
 - Touch the **Control Panels** button to open the Control Panels Menu.
 - Touch the **Network** button on the Control Panels Menu to open the Network Setup Screen.
 - Touch the **IP Addresses** tab to display the system's IP addresses.
 - Record the IP address (it's the top one).
2. On the PC, start Microsoft Internet Explorer (must be version 3.2 or higher) or another web browser.
3. In the browser's address box type in "http://", followed by the controller's IP address. See the illustration below:
- 4.

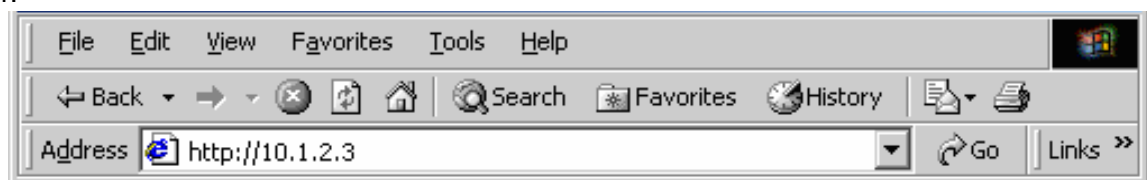

5. Press **Enter**. The web page shown below should appear.

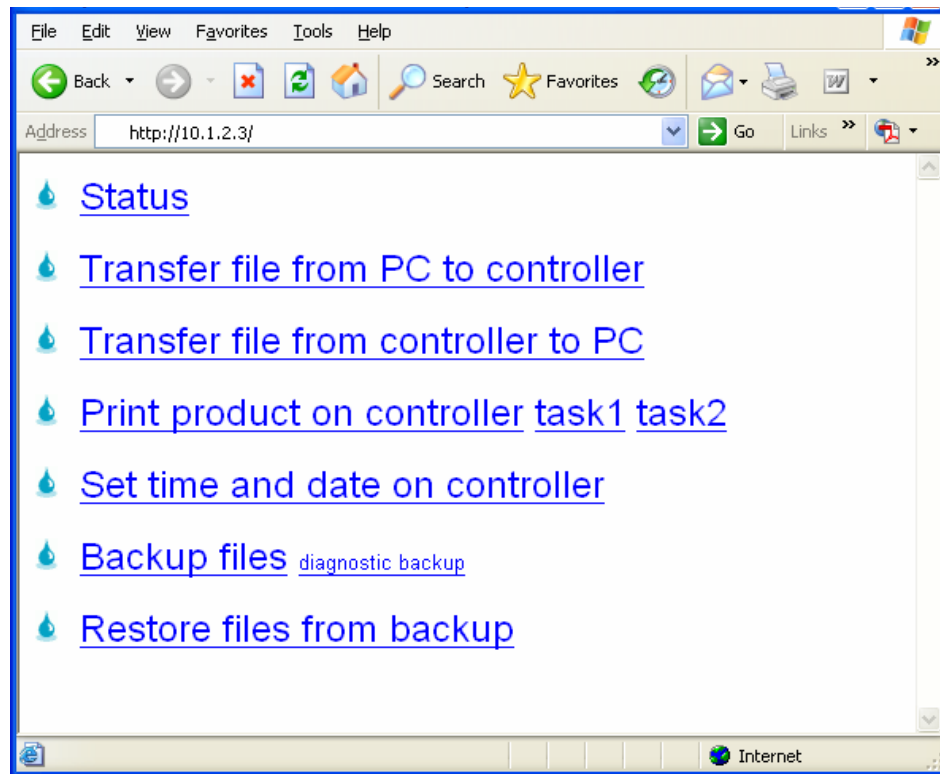

From this screen you can:

- Check Controller Status
- Transfer Files to and from Controller
- Select Messages to Print
- Set Time & Date
- Backup & Restore Files
 - Configurations Files (.cfg)
 - Message Files (.prd)
 - Logo Files (.bmp)
 - Label Files (.alp)

Appendix E: Creating a Logo

Open **Paint** from a PC by selecting **Start, Programs, Accessories**, and then **Paint**.

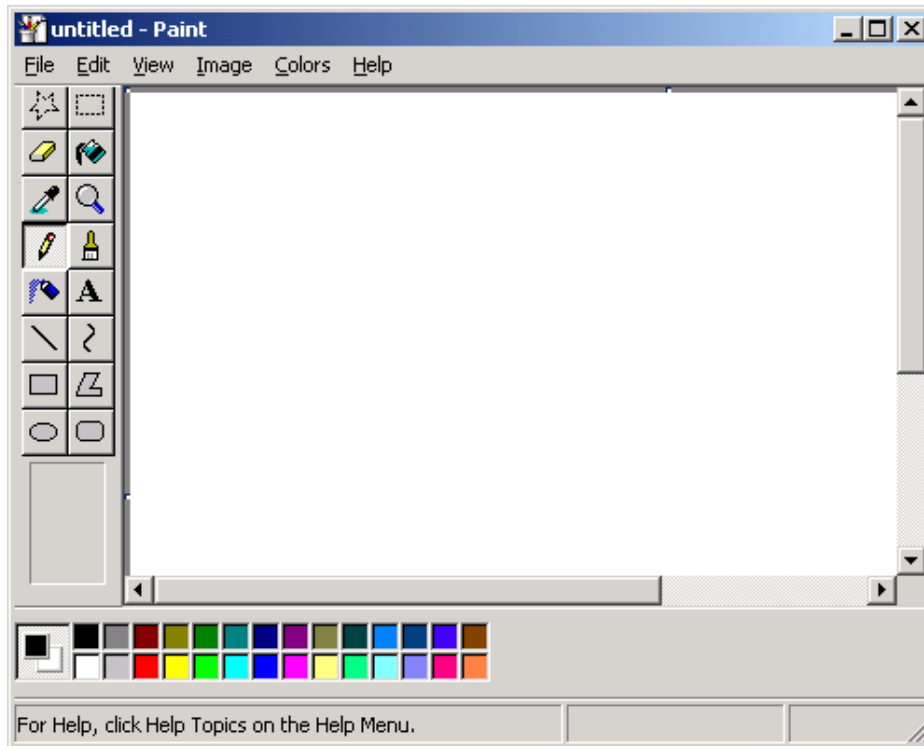

Bring up the **Attributes** dialog box by selecting **Image** and then **Attributes**.

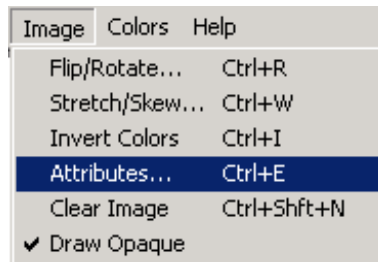

Enter the **Width** and **Height** of the logo in **Pixels**, then select **Black and white**.

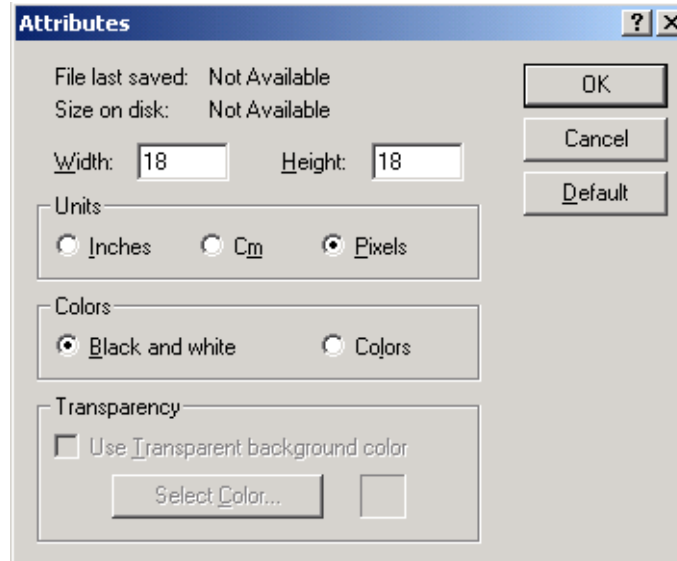

Choose **Yes** at the screen prompt to convert to black and white.

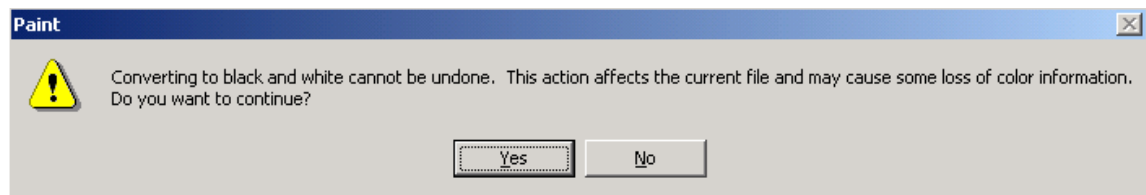

Zoom in by selecting **View, Zoom**, then **Large Size**. This will make defining the pixels easier.

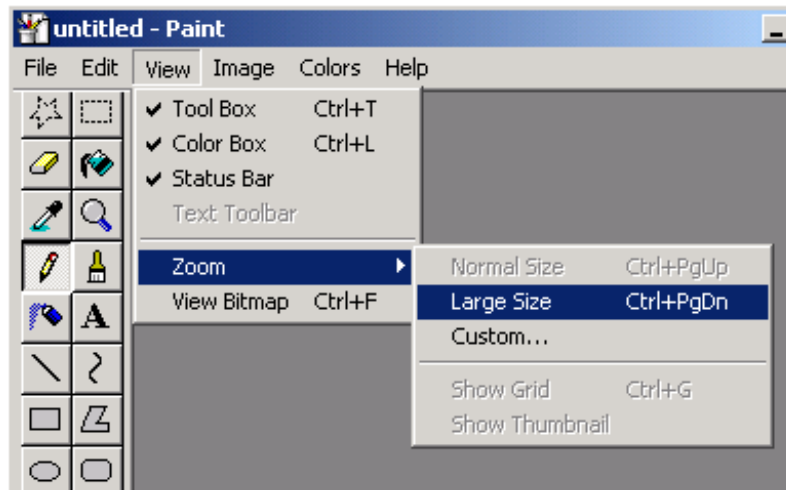

Define the pixels of the logo by using the pencil tool.

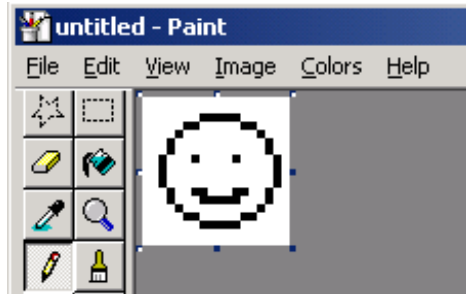

Bring up the **Flip and Rotate** dialog by selecting **Image, Flip/Rotate**.

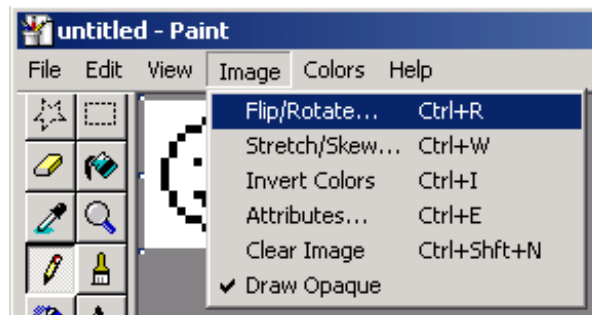

Select **Rotate by angle**, then **270°**.

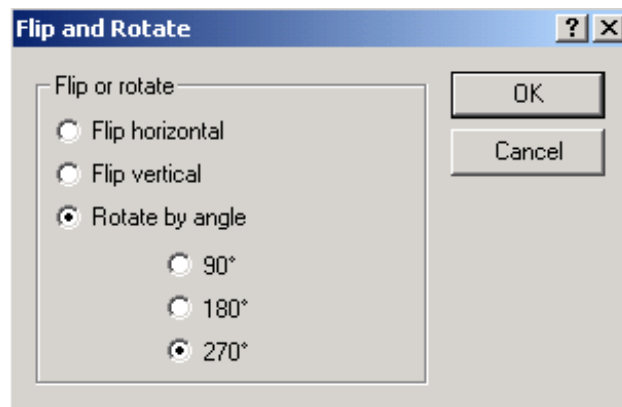

From the **File Menu**, select **Save As...**

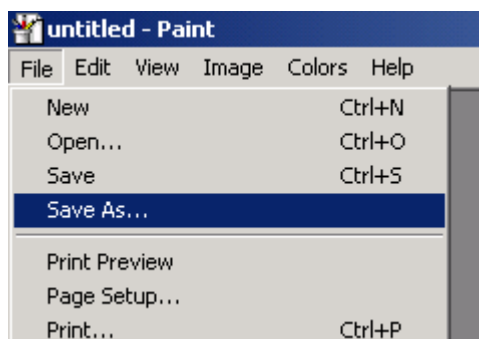

Name the logo and save it as a **Monochrome Bitmap** file in the desired folder.

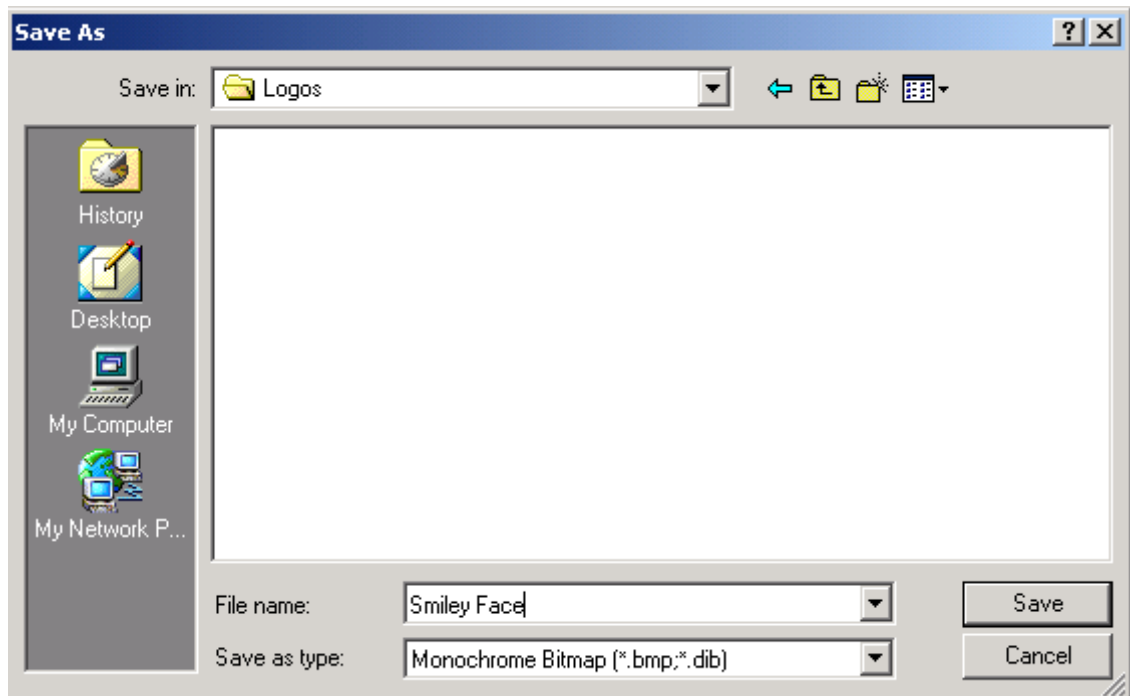

Appendix F: Standard Operating Procedures

FJSOP1 - Removal of FoxJet High Resolution Print Heads

PURPOSE: To detail the procedure for removing a Foxjet High-Resolution inkjet printhead from a production line.

RESPONSIBILITY: Customer or authorized FoxJet Distributor technician.

SAFETY: All personnel performing this procedure must wear proper eye protection and latex gloves.

FREQUENCY: Each time a print head is to be removed from a production line.

PROCEDURE:

1. Initiate the proper controller shutdown procedure, TURN OFF AND UNPLUG THE CONTROLLER from electrical power source to avoid possible electrical problems and/or electric shock.

2. Disconnect all print head cables from the controller.

3. Remove the ink bottle and install the Reservoir Ship Cap.



4. Remove vent cap filter (if applicable) and close the vent cap.

5. For an AMS/APS system, remove Waste Ink Bottle and reinstall the Short Black Protective Shipping Bottle.



6. Install the faceplate cover on the front of the print head (when properly installed it should cover the CP/OP).



7. Insure that all print head covers are properly installed, clean and all screws are in place.

8. Remove all photocell and photocell brackets from the print head, if applicable.
9. Remove screws that hold the print head to the bracketry.
10. Wrap a clean shop cloth around the front of the print head to catch any ink that may leak out and secure the cloth with masking or packing tape.
11. Place a plastic bag over the print head assembly and secure it with tape.

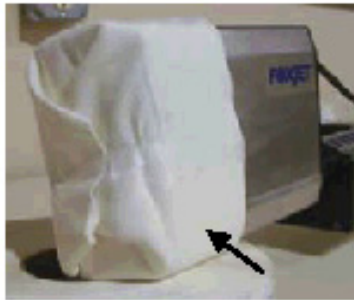

12. If the print head is to be stored for later use, it should be stored in a cool, dry location.
13. If the print head is to be shipped, it should be well padded and packed in its original shipping box.



CAUTION:

Observance and practice of this procedure is critical to insure no damage occurs during shipping.

FoxJet will replace, and charge for, any items found to be missing before it can be returned.

FoxJet may deny warranty coverage if the printer or part has failed as a result of abuse, neglect, improper maintenance, improper shipping, or unapproved modification(s). Please refer to the Master Warranty Statement.

END