



LELA+
LX500P HS
4150

Operator's Manual

4150-010
Revision A

Illinois Tool Works Marking & Coding Division continually improves its products, and reserves the right to change or discontinue specifications and designs shown in this manual without notice and without incurring obligation. Illinois Tool Works has made every effort to verify the information contained in this manual, but reserves the right to correct any error at the time of the manual's next revision.

**© 2013 Illinois Tool Works Inc. All rights reserved.
Printed in the United States of America**

1.0 Introduction



1.1 The LELA+/LX500P HS/4150 Label Applicator

The LELA+/LX500P HS/4150 is capable of dispensing labels at speeds up to 61 cm/s (120 FPM). This system uses a Patent-Pending rewind drive system that eliminates a drive and nip roller assembly. This design allows the system to perform operation from a single Brushless-DC Servo Motor.

1.2 Product Safety

Safety awareness is critical when working with equipment that contains moving parts and extending electric actuators. Please read all warnings and cautions thoroughly before operating this device.

This product meets the requirements of CAN/CSA-22.2 NO.60950-00 * UL 60950 using Illinois Tool Works (Diagraph/FoxJet/Loveshaw) approved items. Units are only tested and qualified with Illinois Tool Works (Diagraph/FoxJet/Loveshaw) approved parts and accessories. Use of other parts or accessories may introduce potential risks that Illinois Tool Works can assume no liability for.

WARNINGS

- **WARNING - Moving parts of this machine can present hazards. Components that cannot be guarded because of loss of functionality are marked with a warning symbol.**
- **When servicing the unit's electronic assemblies, always remove the power cord from the unit to prevent accidental shock.**
- **When running for extended periods of time, use caution when accessing the drive module circuitry. The motor drive power transistors, motor case, and motor heatsink can become hot under constant use.**
- **Wear personal protective equipment, as instructed by your supervisor, when operating or working near this device.**

COMPLIANCE

- **CAUTION: Not for use in a computer room as defined in the Standard for the Protection of Electronic Computer/ Data Processing Equipment, ANSI/NFPA 75.**
- **ATTENTION: Ne peut être utilisé dans une salle d'ordinateurs telle que définie dans la norme. ANSI/NFPA 75 Standard for the Protection of Electronic Computer/ Data Processing Equipment**
- **This unit has been tested and found to comply with the limits for a Class A device, pursuant to part 15 of the FCC Rules.**
- **This unit has been tested to comply with CE Standards.**

- This unit was tested and it was determined that a potential for tipping exists in certain orientations. In compliance with UL safety standards, the stand must be secured to the surface where it is located. Additionally, this type of securing will result in greater product application accuracy.

1.3 Warranty Information

The LELA+/LX500P HS/4150 labeler, including all components unless otherwise specified, carry a limited warranty. For all warranty terms and conditions, contact Illinois Tool Works for a complete copy of the Limited Warranty Statement. Also available on the web at www.diagrap.com.

1.4 Specifications

General Specifications

Category	Parameter
Dimensions (with Yoke)	32 in. (813 mm) L x 19 in. (483 mm) H x 23 in. (584 mm) D
Weight	38 lbs (17.3 kg) (includes yoke, no stand)
Accuracy	±0.0625 in. (±1.58 mm)
Certifications	CE, CSA, FCC approved, Listed (UL 60950)
Supply Roll Capacity LELA+/LX500P HS/4150	14 in. (355.6 mm)
Label Length	1 in. (25.4 mm) Min. to 8.0 in. (203.2 mm) Max.
Label Width	1 in. (25.4 mm) Min. to 5 in. (127 mm) Max.
Dispense Speed	10 FPM (5 cm/s) Min. to 120 FPM (61 cm/s) Max.
Product Rate	1 in. Label 442 PPM Max. 2 in. Label 266 PPM Max. 6 in. Label 124 PPM Max. 8 in. Label 72 PPM Max.
Temperature	41°F - 104°F (5°C - 40°C)
Humidity	10 to 85% RH, Non-Condensing

Electrical Specifications

Category	Nominal	Minimum	Maximum
AC Voltage Supply	100 - 240 VAC,4A 50/60 Hz	90 VAC 47 Hz	264 VAC 63 Hz
Product Detector	Low: 0 to 3 VDC High: 3 to 5 VDC Supplies 24VDC	0 VDC	24 VDC
Product Detector Pulse Width	10 mS	1 mS	Infinite
Warning Tower	0 and 24 VDC 1 Amp sinking	0 VDC 0 mA	24 VDC 1.5 Amps sinking

System Dimensions

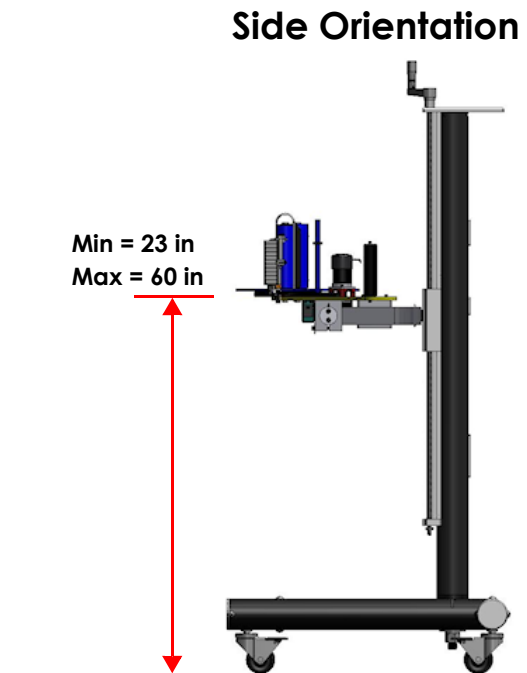
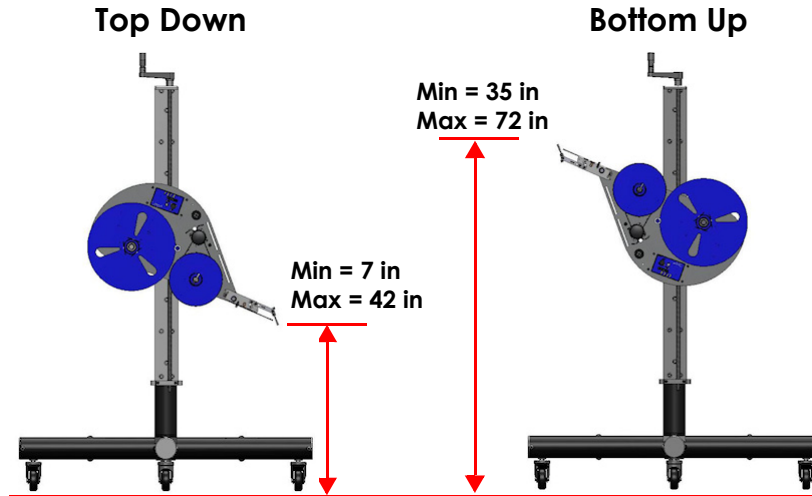
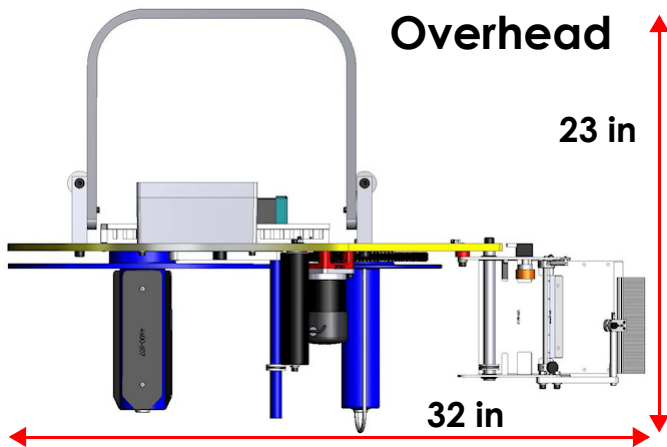
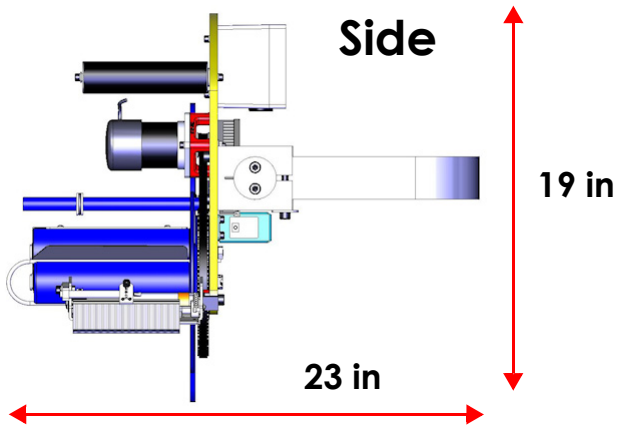
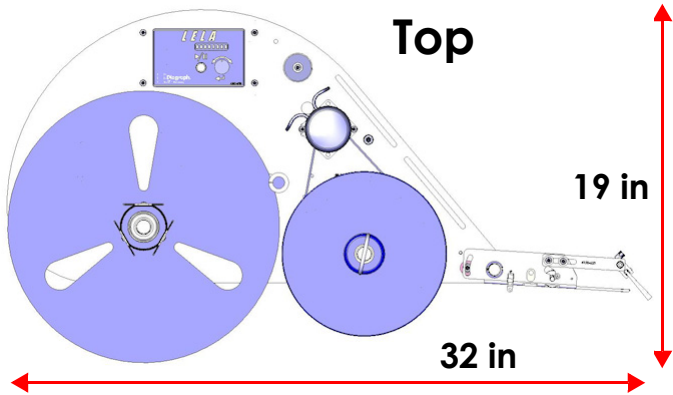

2.0 System Modules



Electric Control Module

- Contains LED Alpha-Numeric Display
- Controls all operation
- Drives Servo motor
- Interfaces to sensors

4150-500

Dancer Arm

- Non-rotating spindle 4600-643
- Performs label/liner braking

4600-617

Unwind Supply Roll

- Indestructible ABS Material
- 14 in. (355 mm) Disk
- 3 in. (76 mm) ID Core

4600-605

Rewind Liner Take-Up

- Indestructible ABS 1-pc Material
- Simple clasp liner keep

4600-606

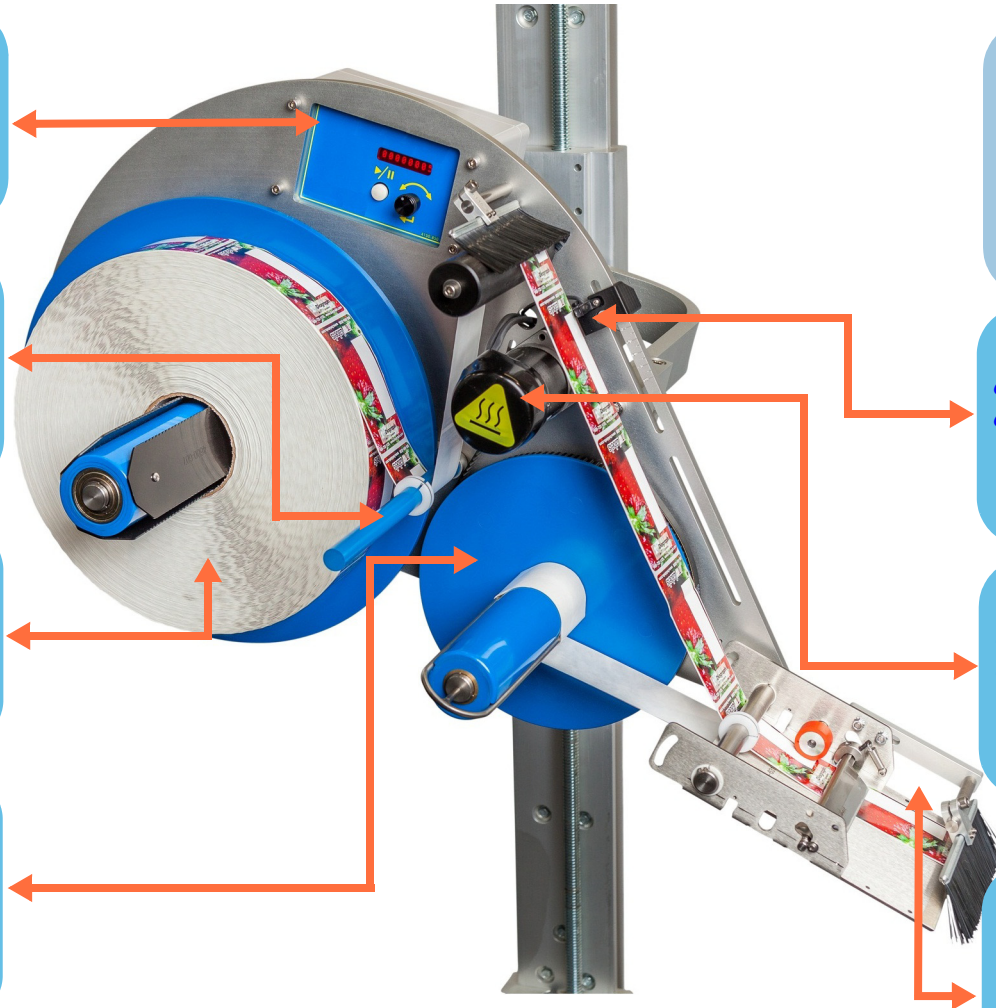

* Warning Tower



- Red, Yellow, and Green LED bulbs
- 24 VDC 5W

6000-828

Gap Sensor Bracket

- Polycarbonate ABS
- used to move gap sensor physically

4150-639

BLDC Motor Drive

- Long-life, Brushless DC Motor
- Hall-Effect Sensors for speed feedback

4600-503

Product Detector

- Diffused light sensor
- 900 mm range
- Light or Dark Operate
- NPN Signal

4600-900

* = Denotes Optional Equipment

3.0 Theory of Operation



The operation of the label dispensing is quite simple. The Product Detector supplies a signal that starts the application sequence. The sequence begins with the countdown of the Delay timer. This value is determined by the user, and it is used to set the position of the label on the product. This is dependent on the speed of the product and the desired location on the product. Once the Delay timer expires, the label feed begins. The label is ramped up to the desired Speed almost instantaneously. This speed is set by the user to match the product's speed on the conveyor. Once the label gap is detected by the labeler's gap sensor, the label is dispensed as far as the Position value dictates. This allows for handling labels of various lengths and shapes. Once the Position is reached, the label liner advancement is halted and the application cycle is considered complete.

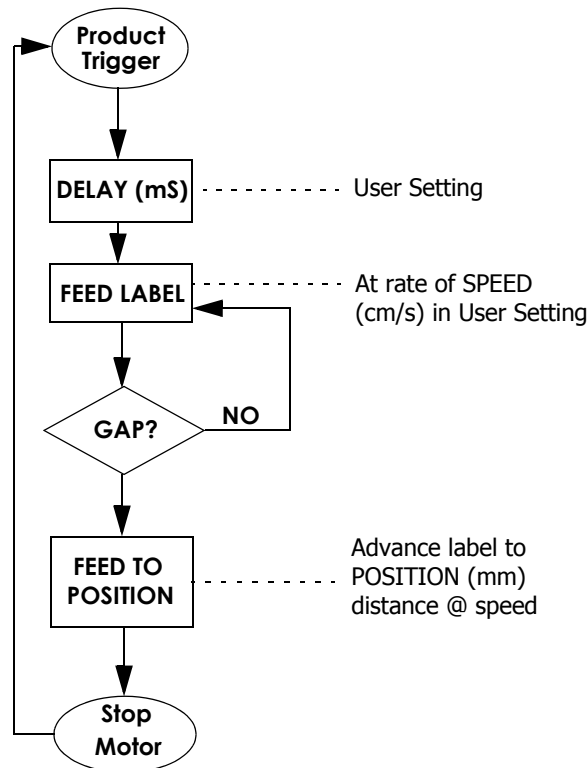

4.0 Setup



STEP 1

Connections

Most of the system cable connections are located inside the Electronic Control Module (ECM). This includes the jumper location for selecting Left-Hand system operation (default is Right). The ECM is located on the rear of the system baseplate. Remove the four (4) Phillips-head screws for attaching the:

- Product Detector
- Optional Warning Tower
- Optional Serial Port Connection



ECM location on rear of the baseplate (shown covered)

ECM with rear panel opened

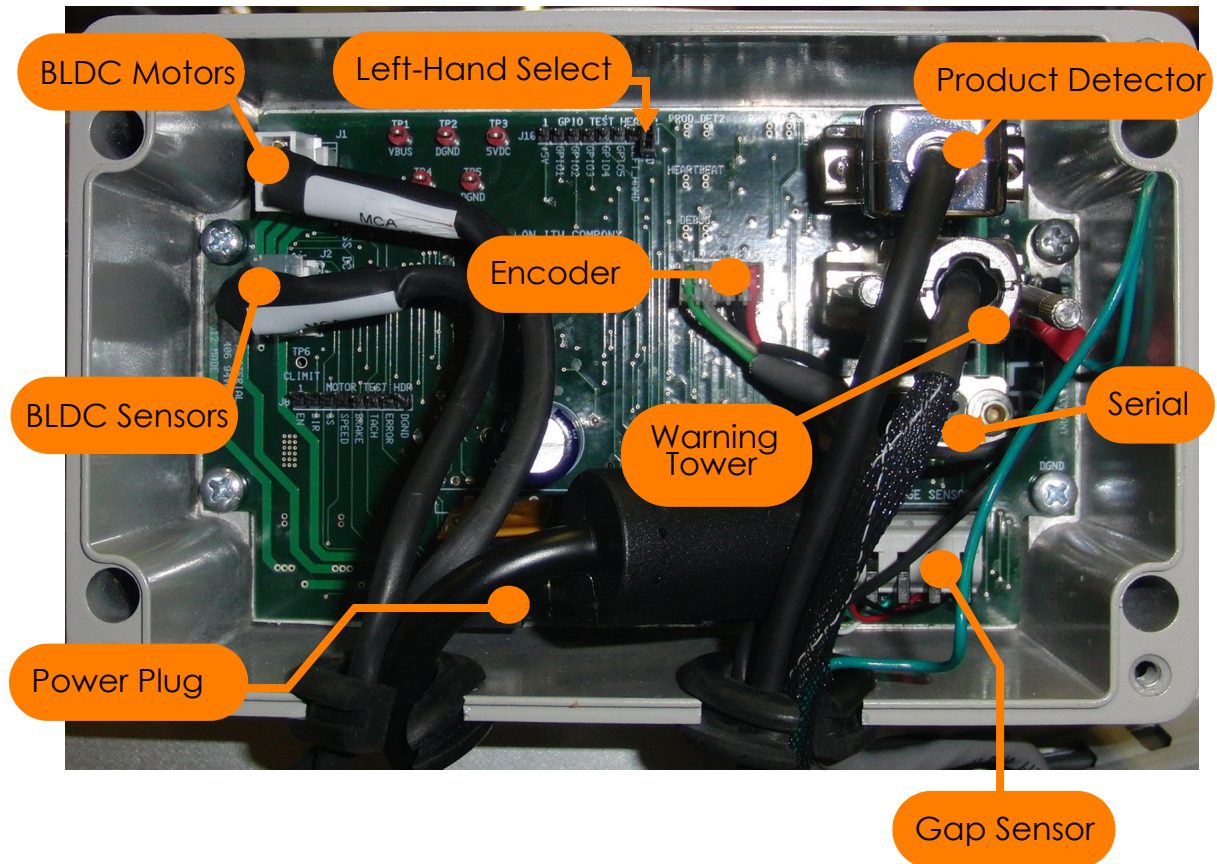

STEP 2

Determine Labeler Orientation

Orientation



Side Orientation

- Side panel of product is to be labeled
- Corner wrapped panels
- Label is to be applied in landscape orientation
- **Not** for tall conveyors where roll change out would be difficult

Top-Down / Bottom-Up Apply

- Top or Bottom panel of product is to be labeled
- More material handling is required for Bottom-Up applications

View

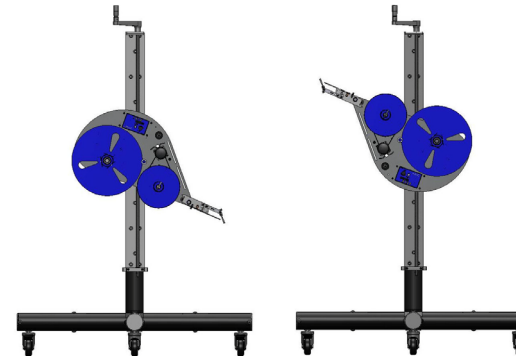
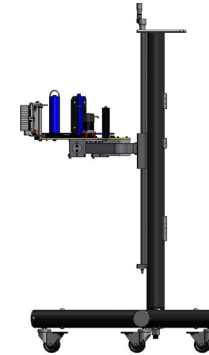

STEP 3

Labeler Alignment with Product

Optimum Labeling Head Positioning

The labeler should be adjusted for position to the product through the yoke, which rotates about two axes. The labeler must be rotated on these axes to obtain a parallel surface when the peel edge meets the product's surface.

Label Supply Roll Positioning

The labeler will not work properly if the label supply angle is beyond 90 degrees, with respect to the ground. This will allow the label roll to slip off of the labeler and can cause liner tracking problems within the labeler.

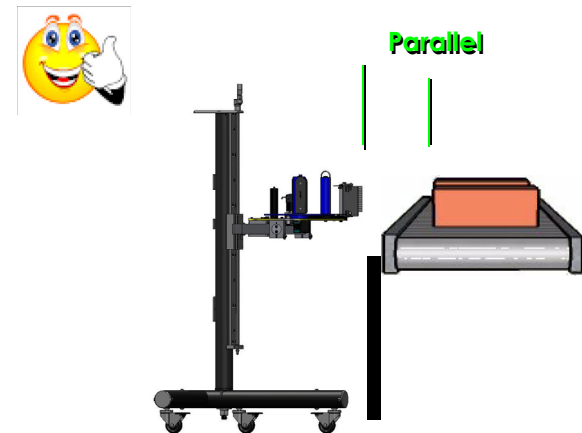
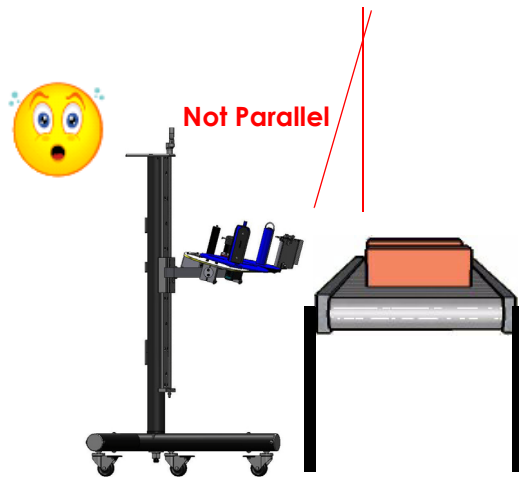
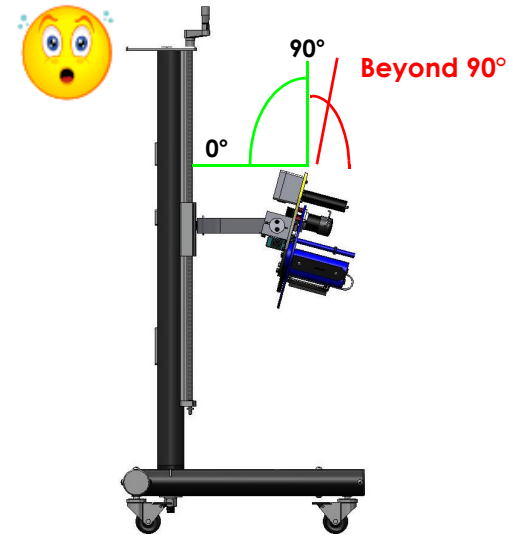

STEP 4 Adjust Settings

Controls

The LELA+/LX500P HS/4150 uses two controls for all of its operational control and value adjustments. The white pushbutton provides three functions:

- When offline, a press of the button transitions the system to online
- When online, a press of the button transitions the system to offline
- When offline, a press and hold of the button feeds one label for test purposes

The black rotary knob allows for menu and value changes. It incorporates a pushbutton for selection. Use the rotary knob to slowly make incremental value changes or rapidly turn to advance the amount by greater values.



Pushbutton control
Press once to run or pause the system. Press and hold to feed a label

Shuttle control
Adjusts values up and down. Press to set.

Navigation

The LELA+/LX500P HS/4150 minimizes control complexity by using a minimum set of parameters to adjust the system operation. There are three basic application adjustments:

- Delay - This is the time to wait in between the product trigger and the start of label application
- Position - This is the distance the label is dispensed beyond the detection of the label's gap. When a label is being dispensed, it is fed forward until the gap is detected. Once the gap is detected, the label will normally need to be fed further to line up the next label on the peel blade edge. This value adjusts this distance.
- Speed - The speed should closely match the speed of the product

There is a built-in label counter that can be viewed while online or in the Information Menu (INFO). This value is reset to zero at power-up and can be reset by pressing the black knob while viewing the count.

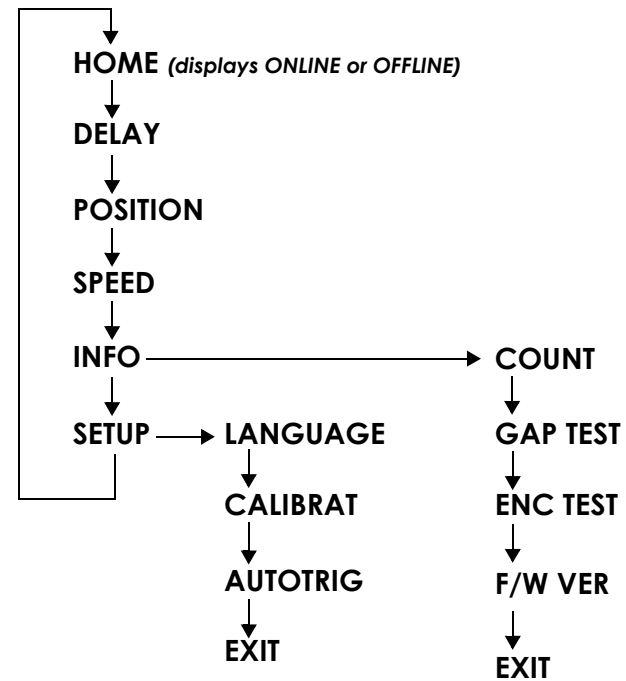

STEP 5**Load the Media****LABEL SUPPLY CHANGEOUT**

Begin by removing the last supply roll core and remaining label liner from the labeler. Insert the new roll over the unwind fins and press roll firmly against the unwind disk [A]. Optionally removes several labels from the liner to create a leader. Route the liner under the dancer arm [B] and between the idler roller [C] and Brush [J]. Pass the liner through the Gap Sensor [E], under the peel blade shaft [D], under the liner speed encoder [F], and hold down plate [G]. Curve liner around peel blade edge and attach to rewind hub [H], using rewind clasp [I] to hold the liner in place. Using the rewind clasp makes removal of the label liner much easier, as it releases the tension on the take-up roll.

With the labeler offline, press and hold the feed button (white user interface button) to register the first label; before the labeler is returned online and the labeler begins running. The label change out can be accomplished in less than 30 seconds by an experienced user.

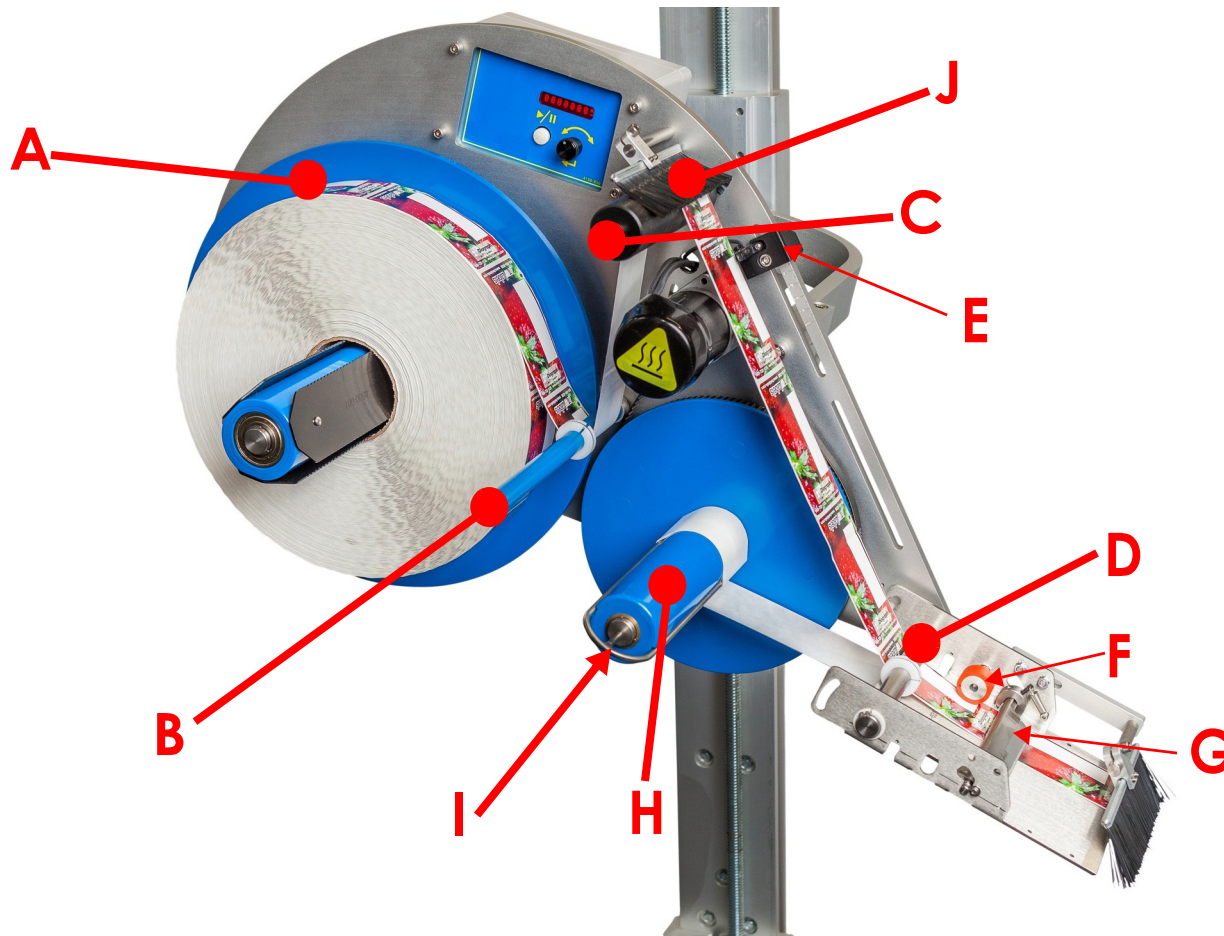

STEP 6

Product Detector

Product Detector for the Application

The standard product detector offered is the Diffuse Light 4600-900 sensor. There are two optional sensor types, one is a break-beam sensor, and the other is a laser with background suppression. The proper product detector can make the difference in label placement and operation.

Product Detector Selector			
Application Detail	Diffuse Light (4600-900)	Break-Beam (4600-901)	Laser (4600-902)
Corrugated brown case, no pre-print	✓	✓	✓
Corrugated brown case, pre-print	x	✓	✓
Tray packs with product gaps in pack	x	✓	✓
Pallets	✓	✓	x
Shrink wrapped products	x	✓	✓
Primary product	✓	✓	✓
Primary product, high speed, high accuracy	x	x	✓

Product Detector Mounting Location

The product detector can be mounted off of the peel blade for applications. This location ensures that any movement of the equipment would not effect the Product Delay. There are application set ups where this location will not work, and there are brackets included for remotely mounting the product detector elsewhere. Listed below are the applications that will require the detector to be relocated:

- Side apply configuration, where the clearance is too close for the product sensor to be mounted in between the system and the conveyor
- High line speeds (greater than 60 FPM) and desired label placement close to the front edge of the product
- The product type requires a break beam sensor, requiring a direct line of sight to a polarized reflector

Product Detector Adjustments

All three of the sensors have the same controls for adjustment. Setting S2 (as shown to the right) controls the sensitivity of the detector. With a sample target product in front of the sensor, adjust this setting. The output LED, L2 in the image, will illuminate with the sensitivity adjustment is correct. The power LED, L1 in the image, will show the signal return strength when the output LED is on. Make sure the sensitivity is set so the green LED is on solid so that slightly less reflective products will still cause a trigger. Once the product is removed from the field of view of the sensor, the green LED will return to indicating power, and will be strongly illuminated.

For break-beam applications using the 4600-902 sensor, the Light/Dark setting S1 should be changed. This inverts the output signal mode to the applicator. Since a break-beam application will normally have an active output for no product detected, the change of S1 will allow the triggering to react to the presence of the product.

Sensor Notes

The break-beam sensor has a polarized retro-reflective lens. This means that it requires a suitable reflector that can provide the correct light phase shift to satisfy the sensor. This prevents reflective products (shrink-wrap, glass, etc.) from falsely triggering the sensor.

The laser sensor incorporates a triangulation method to receive the reflected beam. Using this method, the sensor detects true distance rather than product reflectivity. The setting made on S1 will determine distance to the target product. If products will range in distance, the furthest distance product should be used for adjustment. Ensure that objects beyond the target product range are not detected to avoid false triggers.

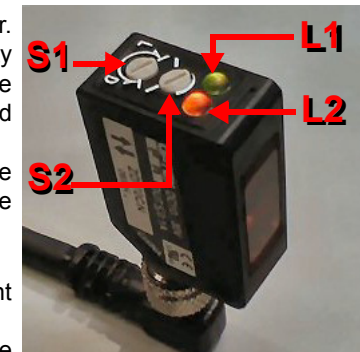

STEP 7

Configure Application Settings

Set the POSITION Value

When the system dispenses a label, it looks for the first label to liner transition (trailing edge of label). Once found, it continues to advance the label for the distance set in the POSITION setting. This arrangement allows for rectangular, circular, and other various label shapes to be used with this sensor. There is one trade-off, however. Since it triggers the gap from the first trailing edge, care should be taken when setting the POSITION value so that the label isn't on the edge of the trailing position. This will cause double feeds or impulse feeds. The following table shows the typical POSITION values, based on the gap sensor position on the ruler on the baseplate. The gap sensor is attached to the baseplate with a mounting bracket to be able to adjust its position for different label sizes.

Table 1: Label Length Table

Label Length	POSITION Value in Menu	Gap Sensor physical position
1in (25.4mm)	0.59in (15mm)	1.18in (30mm)
2in (50.8mm)	0.98in (25mm)	0.39in (10mm)
3in (76.2mm)	1.57in (40mm)	0.79in (20mm)
4in (101.6mm)	3.15in (80mm)	0.79in (20mm)
5in (127mm)	4.25in (108mm)	0.79in (20mm)
6in (152.4mm)	1.77in (45mm)	0.39in (10mm)
8in (203.2mm)	7.09in (180mm)	1.18in (30mm)

Note: The values for Position and Gap Sensor position in the table above should only be used as reference and for different label shapes and different speeds user can change these values as needed.

Note: For speeds higher than 40 cm per second set the position value higher than 15mm.

Position Example

Q: Given a round label that measures 2.5 inches wide by 2.5 inches long, what should the Position value initially be set to?

A: Since the label trips the gap sensor off of the trailing edge, there is roughly 1.3 inch of travel required after the gap to advance the next label to the edge of the peel blade. This means that a Position value of 33 (1.3 in. * 25.4mm/in.) is required.

If the label was a rectangle, we would not have to advance such as large gap distance.

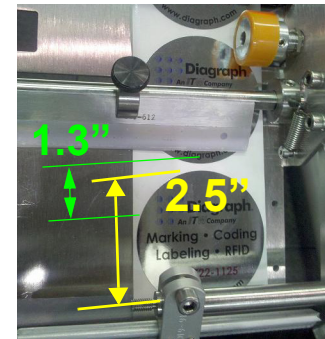

Set the SPEED Value

The speed is set in the metric units of cm/s. The table below shows the close equivalent of cm/s * 2 = FPM.

Table 2: Label Speed Table

Speed (cm/s)	Speed (FPM)
5	9.84
10	19.68
15	29.52
20	39.37
25	49.21
30	59.05
35	68.89
40	78.74
45	88.58
50	98.42
55	108.27
61	120.08

Speed Example

Q: What is the Speed setting required for a 75 FPM conveyor?

A: Using the divide by 2 estimation above, a value of 37 cm/s can be tried. The precise value would be 38.1 cm/s, so 37 would be a close estimation.

STEP 8

Configure Application Settings (Cont.)

Set the DELAY Value

This is measured in milliseconds (ms). The system will be the most accurate for label placement with the delay value as small as possible. This means that the product detector should be placed parallel to the desired label location on the product. This is usually not right on the peel blade edge, unless the desired label placement is right on the product's leading edge, but rather a location downstream of the peel blade.

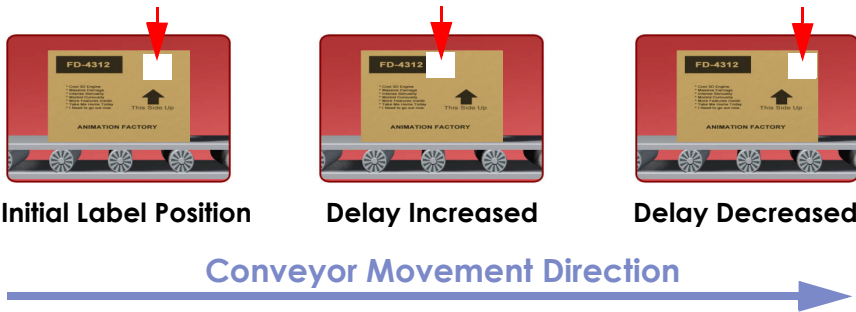

Calibrate the GAP Sensor

Place a clear section of liner in the gap sensor (see picture on right). It is important that the liner is under some tension, to represent the position experienced when running.

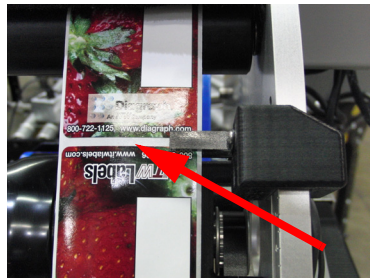

Enter the Setup menu, and select CALIBRAT(E). Follow the instructions on the display, which require the user to press the black knob to set the value. This value will be displayed on the screen. Normal values are between 20 and 40. This represents how much light is getting through the liner.

A value of 60 indicates there is an error, or the liner is too opaque. Recycled paper or kraft paper can be too opaque for the standard sensor, and cannot be used. A value less than 10 indicates either a clear liner (which is okay to use), or a problem if the liner is standard paper.

Set the Machine Hand Configuration

This should be set at the time of manufacture. The system can either be a Left or Right hand system. This is determined by the orientation of the label image and the position of the system on the conveyance line. If the jumper is placed across pins 1 and 2, the system will perform as a left handed system. No jumper indicates a right hand system.

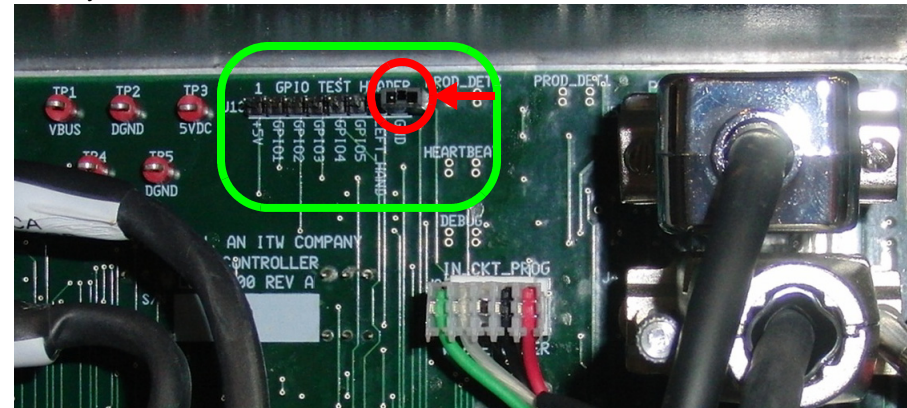

Label Unwind Direction and Machine Orientation

For reference, the label unwind chart is listed below. Types 3 and 4 must be matched to the hand of the labeling system. Type 3 should be used on a left-handed system, while a Type 4 should be used on a right-hand system.

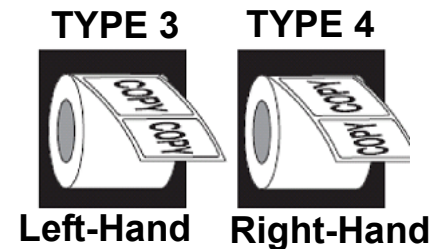

STEP 9

Runtime Adjustments

Observed	Reason	How to Correct
FEEDING ISSUES		
LABEL FEEDING OUT TOO FAR	<ul style="list-style-type: none"> Position value incorrectly set 	<ul style="list-style-type: none"> Use Label Length Table on page 14
LABEL NOT FEEDING OUT FAR ENOUGH	<ul style="list-style-type: none"> Position value incorrectly set 	<ul style="list-style-type: none"> Use Label Length Table on page 14
LABELS FEED OUT WITHOUT PAUSING AT LABEL GAP CONTINUOUSLY	<ul style="list-style-type: none"> Label Gap Sensor not calibrated Gap Sensor not connected, dirty, damaged, or faulty 	<ul style="list-style-type: none"> Calibrate Label Gap Sensor according to instructions <u>Calibrate the GAP Sensor on page 15</u> Check connections and verify gap sensor is clear of dust and contamination. Clean with compressed air or optical cleaning solution. Test sensor readings in Diagnostics as described in <u>Diagnostics on page 18</u>
LABEL DOUBLE FEEDS ONCE IN A WHILE	<ul style="list-style-type: none"> Label Gap Sensor needs re-calibration Gap Sensor dirty, damaged, or faulty Label stop position on edge of label gap 	<ul style="list-style-type: none"> Calibrate Label Gap Sensor according to instructions <u>Calibrate the GAP Sensor on page 15</u> Clean with compressed air or optical cleaning solution. Test sensor readings in Diagnostics as described in <u>Diagnostics on page 18</u> Increase (or decrease) Position value to avoid label stop on edge of next label.

5.0 Optional Thermal Jet Printing



The LELA+/LX500P HS/4150 is able to integrate with a thermal jet printing head, where the labeler is controlling the print trigger. The Labeler will send the start of print trigger when the label speed has reached the feed speed set by the user. The TJ print position is determined by the product detector offset in the print head itself. Likewise, the print speed is determined by the setting adjustment in the TJ head. Modifying these values or the message can be done through the TJ printer's serial port connected to a PC, Handheld, or Controller. Once the information has been transferred, it is not necessary to stay connected to the print head. For frequently changing speeds, print positions, or messages, it is advantageous to use the Handheld device.

5.1 TJ Printer Setup

In order for the labeler to trigger the print head and signal it when to print, the printer's DB9M port with the Y-Cable (P/N: 4100-961). The DB9M end of the cable connects to the LELA+/LX500P HS/4150's Warning Tower (J4), while the other DB9F reconnects to the optional warning tower. The TJ needs to be configured to use the external photosensor trigger, which is done through the TJ software:

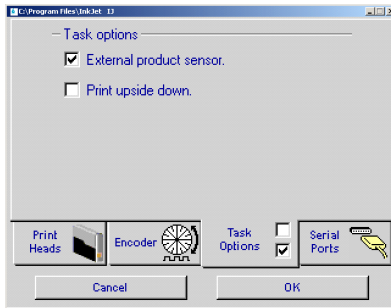

External Product Sensor

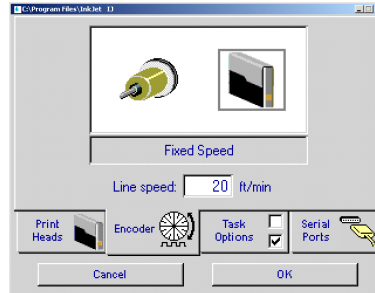

Print Speed

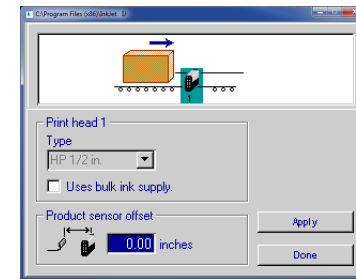

Product Sensor Offset

The Print Speed and Delay are set using the same software. Keep in mind that the feed speed of the LELA+/LX500P HS/4150 is set in cm/s, which is close to half the value will be in FPM. For example, if the labeler is set to 30 cm/s, the TJ printer should be set to 60 FPM. Information on creating a message and other print head setup will be found in the product manual for the TJ system.

5.2 Mounting Adjustments

The print head mounts to the labeler's baseplate through the lower slot. Position the TJ printer to be at the leading edge of the label. The print position across the label is determined by the physical adjustment of the mounting bracket.

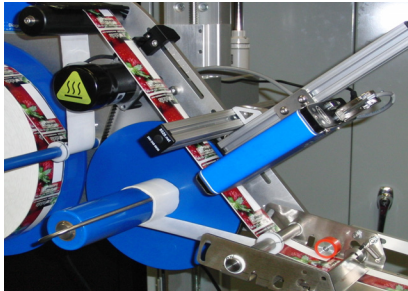

6.0 Troubleshooting



Error Messages

These messages are displayed in a scrolling manner across the red LED screen.

“ERROR...LABELS OUT”

Meaning	Label supply is empty
Detected	The web encoder does not detect movement of the liner when the motor is commanded to move
Solution	Replace label roll

“ERROR...MOTOR CIRCUIT OR MOTOR SENSOR”

Meaning	BLDC Motor Driver Reports an Error
Detected	<ul style="list-style-type: none"> • Motor stalled • Hall Effect sensor cable not connected or damaged • Undervoltage lockout • Invalid commutation sensor code • Shutdown, or overcurrent shutdown
Solution	<ul style="list-style-type: none"> • Liner didn't separate from empty roll core, causing a stall • Check Hall Effect sensor cable (Connecting to J2 on the ECM) • Power supply failure • Incorrect cabling • Stall condition. Cycle power to clear

Diagnostics

These are built-in tests to troubleshoot the sensors

Liner Speed Encoder Test

Test Purpose	Ensures that liner encoder is accurately reading both channels of the sensor, and the proper number of pulses are sensed for a full rotation
Test Step 1	A. Start with the system offline B. Mark a small line on the liner encoder wheel to denote top position
Test Step 2	A. Enter the INFO menu B. Select ENC TEST
Test Step 3	A. Carefully rotate the liner wheel one rotation B. Do not allow the wheel to jiggle backwards during the rotation C. Observe the count on the display
Results	<ol style="list-style-type: none"> 1. If the count reads around 400, the encoder is working correctly 2. If the count reads around 200, the encoder is missing counts from one channel. Check cabling and encoder. 3. If there is no count, or very few counts, check the cable and/or replace the cable and encoder 4. Make sure encoder wheel setscrew is firmly holding to encoder shaft

Gap Sensor Test

Test Purpose	Verify the gap sensor is seeing the difference between liner and label+liner
Test Step 1	A. Enter the INFO menu B. Select GAP TEST
Test Step 2	With no material in the sensor, the value displayed should be less than 10. If the value is 60, cable the cabling and/or replace the sensor
Test Step 3	With just liner in the sensor, the value should be around 15 ~ 50 for white liner. Recalibrate sensor if otherwise

7.0 Electrical Interfacing



J5 - Product Detector(s)	
PIN	Pin Description
Pin 3	Ground
Pin 4	Product Detector Input 2 (NPN)
Pin 6	+ 24 VDC Supply
Pin 8	Product Detect Input 1 (NPN)
Pins 1,2,5,7,9	N/C

J4 - Warning Tower	
PIN	Pin Description
Pin 1	Ground
Pin 4	Red (Ground Switched)
Pin 5	Yellow (Ground Switched)
Pin 6	+ 24 VDC Supply
Pin 7	Green (Ground Switched)
Pin 8	Auxiliary Output
Pin 2,3,9	N/C

J3 - Serial Communications	
PIN	Pin Description
Pin 2	Transmit RS232
Pin 3	Receive RS232
Pin 5	Ground
Pin 9	+ 5VDC
Pins 1,4,6,7,8	N/C

LELA ECM Board (Cover Removed)

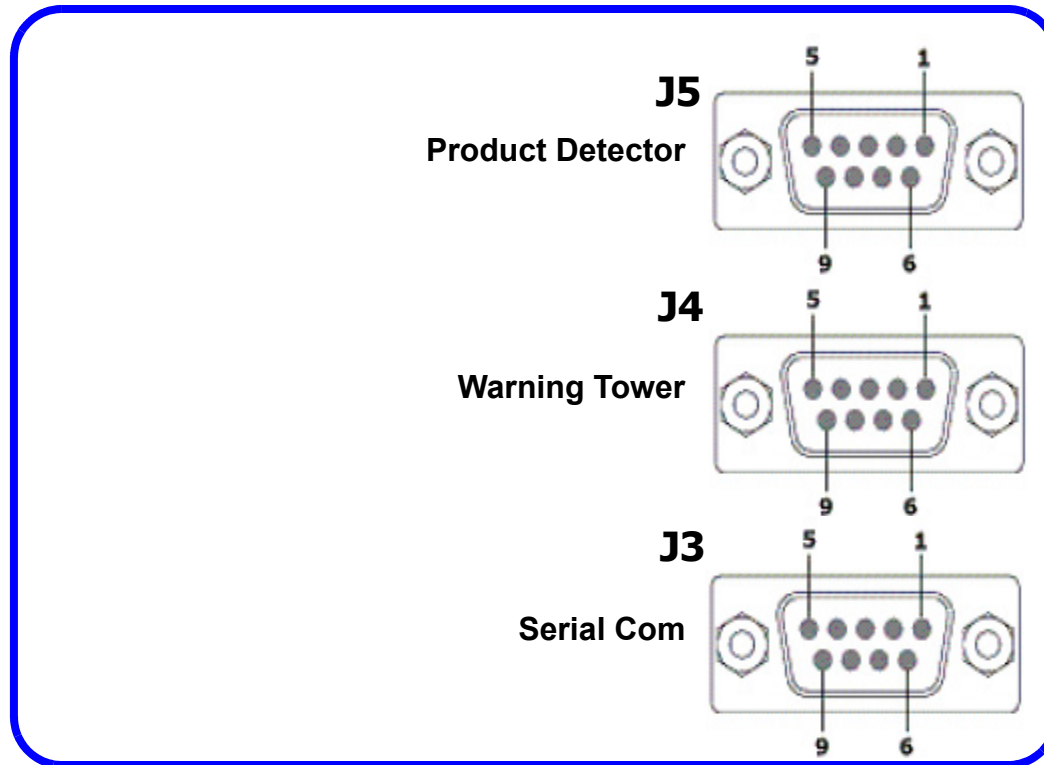

8.0 Maintenance Schedule



Area	Daily	Monthly	Two Years	Description
Clean Label Gap Sensor		√		Use a soft lint-free cloth to wipe all dust and contaminants free. Be careful not to damage the plastic lens with alcohol-based solvents.
Clean Peel Blade /Hold-Down Plate		√		Use isopropyl alcohol and soft lint-free cloth to wipe all dust and contaminants free.
Clean Product Detector Sensor(s)		√		Use a soft lint-free cloth to wipe all dust and contaminants free. Be careful not to damage the plastic lens with alcohol-based solvents.
Clean Baseplate Spindle and Roller		√		Use isopropyl alcohol and soft lint-free cloth to wipe all dust and contaminants free.
Inspect Rewind Belt		√		Check for frayed edges and exposed reinforcement fibers.
Replace Rewind Belt			√	Remove Rewind disk by taking off E-clip. Keep belt loose by loosening the motor mount screws. Replace belt and reinstall the Rewind disk.
Replace Unwind Dancer Spring			√	Unwind spring can be accessed through the slots of the Unwind disk.

9.0 Interconnection Diagram

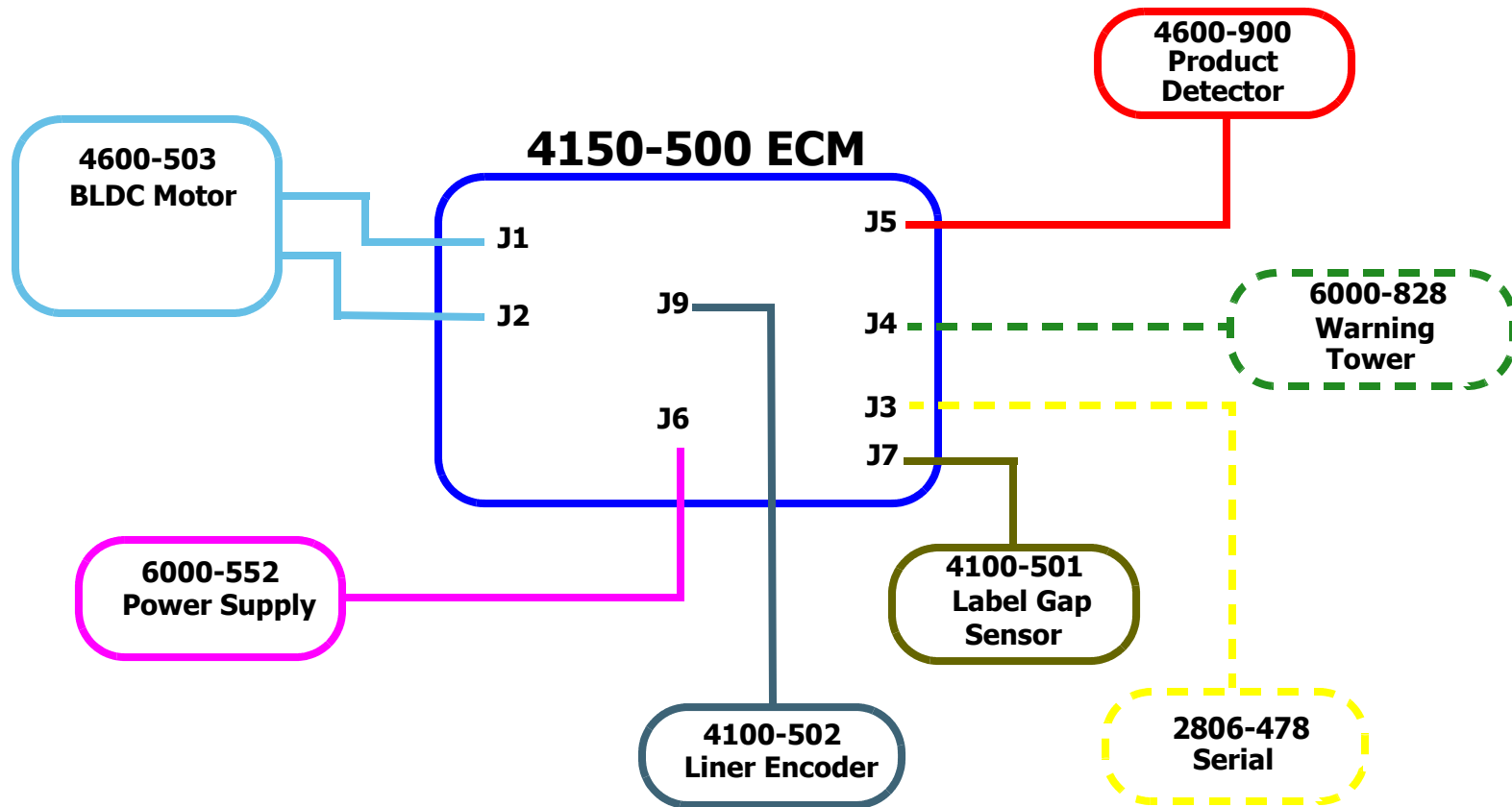

Interconnection Diagram

10.0 Spare Parts List - System



Spare Parts List

Part Number	Recm'd. Spare Part	Description
DOCUMENTATION		
4150-010		LELA+/LX500P HS/4150 User Manual
LELA+ /LX500P HS/4150		
6000-522		Power Supply (Auto-Ranging, 24 VDC Output)
4600-511		AC Power Cord
4600-643		Unwind Dancer Arm Spindle
4150-500		ECM Circuit Board Assembly
4150-300	√	Main MCU PCB Assembly
4600-503		Rewind BLDC Motor
4100-501	√	Label Gap Sensor
4100-502		Liner Speed Encoder
4100-634	√	Liner Speed Encoder Wheel
4600-647		Rewind Clasp
4150-950	√	MAINTENANCE KIT: Wear Items Set Includes: (2) Timing Belts, (2) Spindles, (2/ea.) Springs, (3) Unwind Fins, (4) Web guides, (1) Nylon Brush Replacement
4600-900		Product Detector - Diffused Light
OPTIONS		
6000-828		LED Warning Tower Assembly
4600-622		Stand Cleats (to secure stand to floor, yet allow removal access) Three required per stand



4150-950N Rev A
Reference Sheet
WEAR ITEMS KIT, LELA+

PART NO.	DESCRIPTION	QTY.	IMAGE
6146-611	BRUSH, NYLON, 5"W X 1.92"L	1	
4600-607	RETAINER, LABEL CORE	3	
6105-066	SPRING COLLAR	4	
5331-220	SPRING, EXTENSION (DANCER ARM)	2	 2.25"L
6146-647	SPRING, EXTENSION (HOLD DOWN)	2	 1.00"L
6145-811X4.25	TAPE, PEEL BLADE, CUT TO 4.25"	2	
6145-811X5.75	TAPE, PEEL BLADE, CUT TO 5.75"	2	
4150-604	TIMING BELT, XL, 150 GRVS X .375"W	2	
4600-643	URETHANE SPINDLE	2	

11.0 WideWeb Parts List - System



WideWeb Parts List

Part Number	QTY	Description
4100-603X8	1	8.0" long idler roller
4100-631X7	1	7"wide peel blade
4100-632X8.88	1	8.875" long peel blade shaft
4100-637X5.13	1	5.13" long 3/8 round female shaft
4700-643X8.13	2	8.13" long 3/8 round female standoff
6146-612X7	1	7" Wide LELA+ holddown asm

12.0 System Drawings - Top Level



System Drawings

ITEM	PART NO.	DESCRIPTION	MFR / VENDOR	4150-100R/QTY.	4150-100L/QTY.
54	4600-648	TIMING PULLEY, 15 TEETH		1	1
53	4150-604	TIMING BELT, XL, 150 GRVS X .375" W		1	1
52	6105-423	TIE MOUNT, #4 SCREW		1	1
51	6105-066	SPRING COLLAR		1	1
50	4600-608	SPINDLE, UNWIND-REWIND	---	2	2
49	4150-602	SPACER, MOTOR		1	1
48	6145-665	SPACER, DLERIN, UNWIND/REWIND	---	1	1
47	4150-639	SENSOR MOUNT	---	1	1
46	5081-735	SCR, M8 X 1.25 X 50, SHCS, SS		2	2
45	5081-730	SCR, M8 X 1.25 X 25, SHCS, SS		7	7
44	5241-726	SCR, M8 X 1.25 X 25, BUT HD, SS		1	1
43	5081-731	SCR, M8 X 1.25 X 12, SHCS, SS		2	2
42	5081-729	SCR, M6 X 1 X 25, SHCS, SS		1	1
41	5081-728	SCR, M5 X 0.8 X 18, SHCS, SS		6	6
40	5081-727	SCR, M5 X 0.8 X 12, SHCS, SS		9	9
39	5081-737	SCR, M5 X 0.8 X 50, SHCS, SS		1	1
38	5081-736	SCR, M5 X 0.8 X 40, SHCS, SS		1	1
37	5030-711	SCR, M4 X 0.7 X 6, SOCSET, CUP PT, SS		2	2
36	5101-601	SCR, M3 X 0.5 X 8, FL HD PH, SS		1	1
35	5072-503	SCR, 3/8-24 X 1", HEX HD CAP, SS		2	2
34	5260-602	SCR, #4 X 3/8L, HI-LO, PAN HD PH, SS		1	1
33	4150-605	REWIND DRIVE ASSEMBLY		1	1
32	4600-647	REWIND CLASP	---	1	1
31	5321-219	RETAINING RING, C-CLIP, 3/4"		2	2
30	5321-217	RETAINING RING, 3/8, SS		1	1
29	4600-607	RETAINER, LABEL CORE	---	3	3
28	4600-900	PRODUCT DETECTOR		1	1
27	6000-522	POWER SUPPLY, 24V, 9.2A, MEANWELL		1	1
26	4600-619	POWER SUPPLY BRACKET		2	2
25	4100-630R	PEEL BLADE ASSEMBLY, RIGHT HAND		1	-
24	4100-630L	PEEL BLADE ASSEMBLY, LEFT HAND		-	1
23	4150-850	OVERLAY, LELA+		1	1
22	5305-110	NUT, M6 X 1, SS		1	1
21	5309-315	NUT, LOCK, M5 X 0.8, EXT TOOTH, ZN		1	1
20	4600-503	MOTOR KIT, BLDC		1	1
19	4100-603	IDLER ROLLER		1	1
18	4600-616	HOUSING ASSY, PIVOT		1	1
17	4100-501	GAP SENSOR ASSEMBLY		1	1
16	5750-039	FASTENER, #6 X 1/2 HI-LO, PAD HD		6	6
15	5331-220	EXTENSION SPRING		1	1
14	4150-500 ³	ECM, LELA+		1	1
13	6145-626	EAR, YOKE ATTACHMENT PUCK	---	2	2
12	6145-602	EAR, YOKE	---	2	2
11	6000-634 ⁵	CAP, VINYL, ROUND		1	1
10	4600-511	CABLE, LIGHT-DUTY POWER		1	1
9	4100-503 ³	CABLE, GROUNDING Y		1	-
9	4100-503 ³	CABLE, GROUNDING Y		-	1
8	4600-510	CABLE RACEWAY		1	1
7	6146-611	BRUSH, NYLON, 5"W x 1.92"L		1	1
6	6146-610	BRACKET, BRUSH ATTACHMENT		1	1
5	4150-600	BASE PLATE		1	1
4	4600-617	ARM ASSY, DANCER		1	1
3	6150-600	ANCHOR, EXTENSION SPRING, 8-32		2	2
2	4700-643	3/8 ROUND FEMALE STANDOFF 6" LONG		1	1
1	4100-637	3/8 ROUND FEMALE SHAFT, 3" LONG		1	1

REVISIONS					
REV	ECN	DESCRIPTION	DATE	APPROVED	
A	LPD00616	RELEASE DRAWING	5/2/12	RWB	
B	LPD00684	CHANGED GAP SENSOR BRACKET	11/14/2012	RWB	

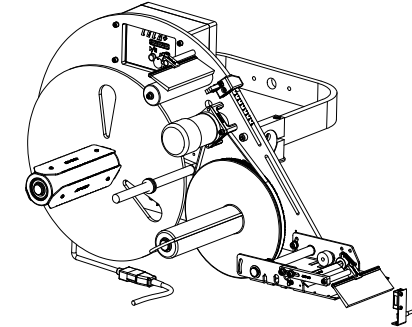

- NOTES:
- 1. APPLY LOCTITE 242 TO SCREW PRIOR TO ASSEMBLY.
 - 2. TIGHTEN SCREWS TO TORQUE VALUES SPECIFIED ON THE DRAWING.
 - 3. COMPONENTS INCLUDED IN THE ELECTRICAL KIT 4150-504.
 - 4. CLEAN SURFACE WITH ISOPROPNOL BEFORE APPLYING OVERLAY.
 - 5. COMPONENTS INCLUDED IN THE MOTOR KIT, BLDC, 4600-503.
 - 6. PLACE TIMING PULLEY FLUSH WITH THE END OF THE MOTOR SHAFT.

ITEM	PART NO.	DESCRIPTION	MFR / VENDOR	4150-100R/QTY.	4150-100L/QTY.
63	4100-610	YOKE ARMS		1	1
62	5310-318	WASHER, SPLIT LOCK, #10, SS		2	2
61	5310-801	WASHER, FLT, RD FIBER, 3/4"ID-1"OD		2	2
60	5310-810	WASHER, FLAT, NYLON, 3/8ID-3/4OD		1	1
59	5310-041	WASHER, FLAT, 5/16, SS		1	1
58	5310-030	WASHER, FLAT, #10, SS		4	4
57	5310-049	WASHER, FENDER, 5/16 X 1-1/4 X 1/8		2	2
56	4600-643	URETHANE SPINDLE		1	1
55	4600-605	UNWIND ASSY		1	1

CONFIDENTIAL THIS DOCUMENT CONTAINS CONFIDENTIAL INFORMATION OF ITW CODING AND MARKING AND IS NOT TO BE COPIED, USED OR DISCLOSED TO OTHERS WITHOUT THE EXPRESS WRITTEN CONSENT OF ITW CODING AND MARKING.	UNLESS OTHERWISE SPECIFIED: ALL DIMENSIONS ARE SHOWN IN INCHES. ALL DIMENSIONS APPLY AFTER FINISH. REMOVE BURRS	FILE NAME 4150-000	
	TOLERANCES: LINEAR 2 PLACE (.XX) ±.015 3 PLACE (.XXX) ±.005 HOLE DIAMETERS ±.005 ANGULAR MACHINE SURFACE ±1°	DWN KROEPEL 4/26/12	
		APP RBIXEN 4/26/12	
		APP XX XX	
		INSP PROC	TITLE: LEADING EDGE LABEL APPLICATOR +
NEXT ASSEMBLY	MODEL	MATL SPEC	CAGE CODE
			SCALE: 1:8
			SHEET 1 OF 7
			SIZE B
			DWG NO 4150-000
			REV B

12.1 System Drawings - Exploded 1

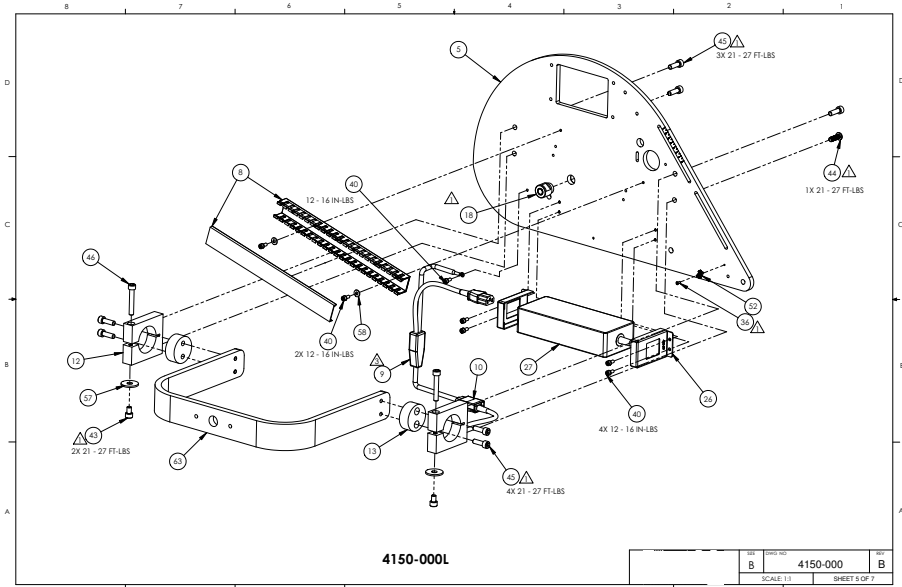
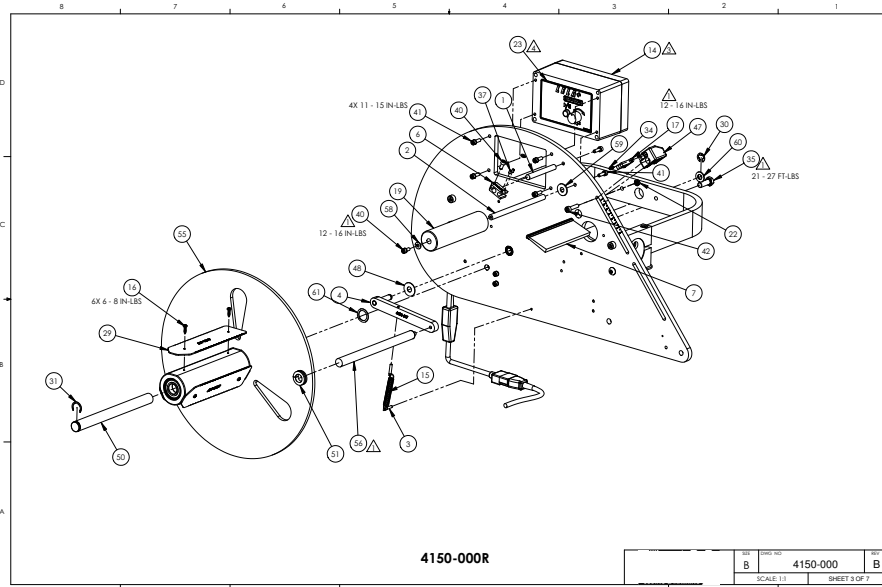
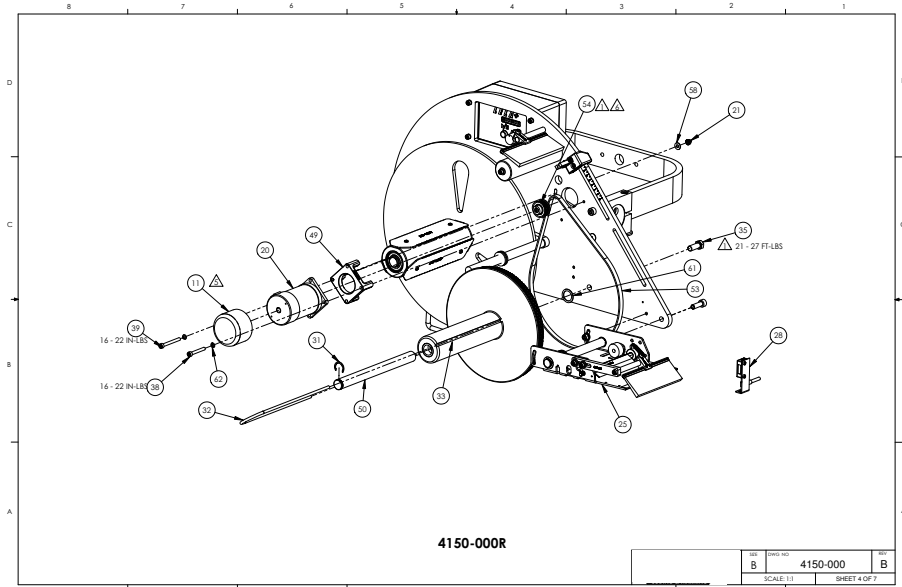
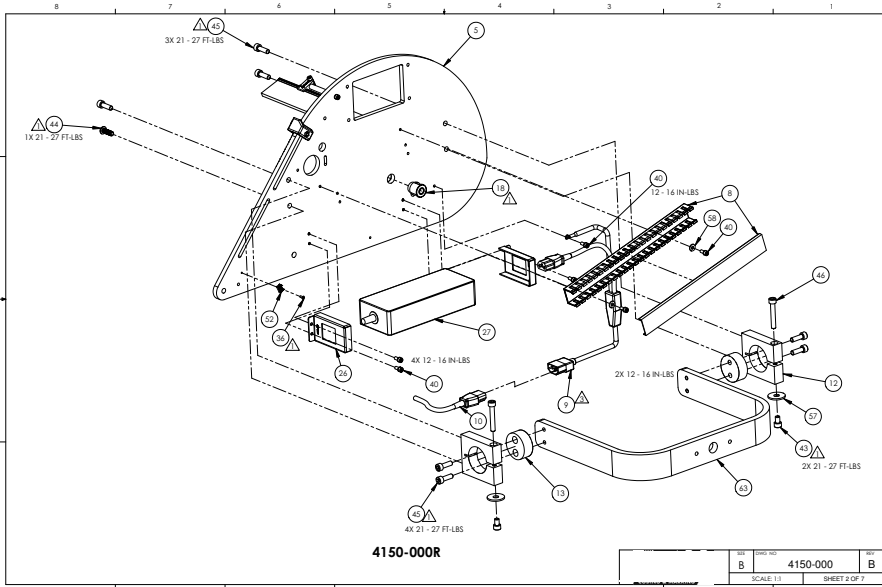

System Drawings

12.2 System Drawings - Exploded 2

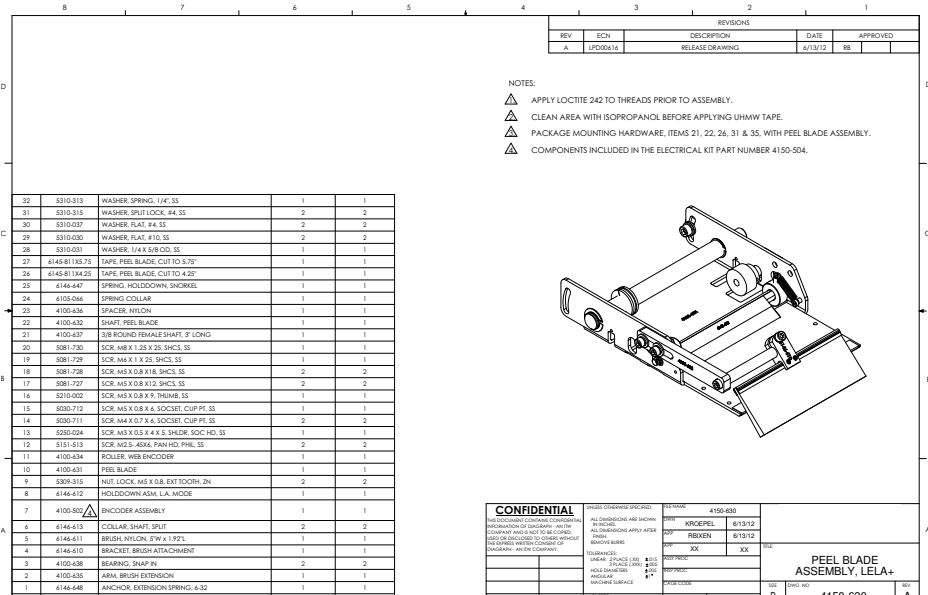
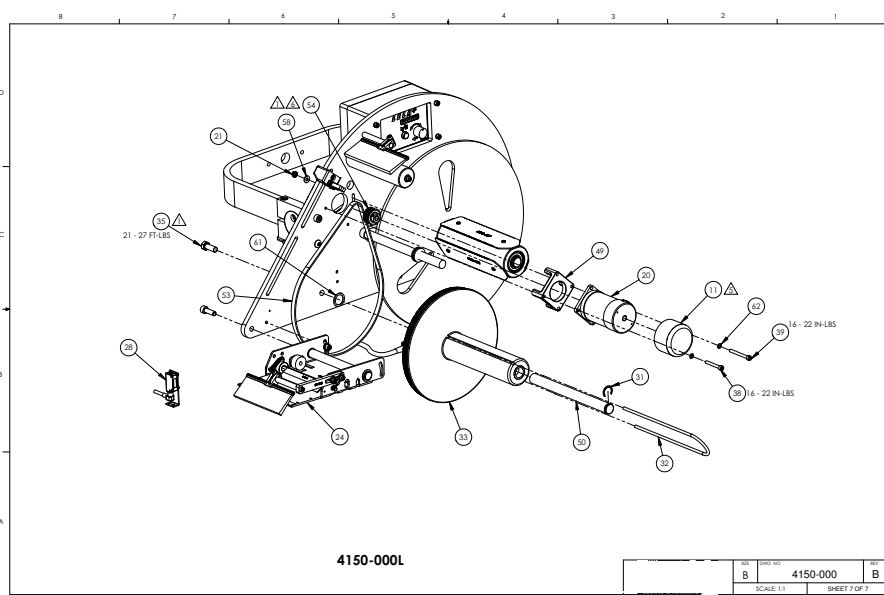
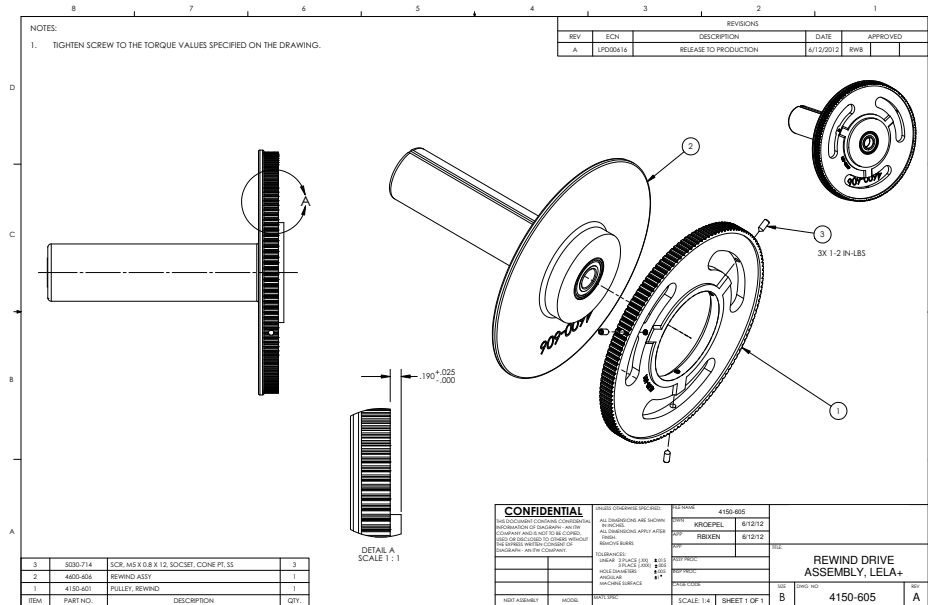
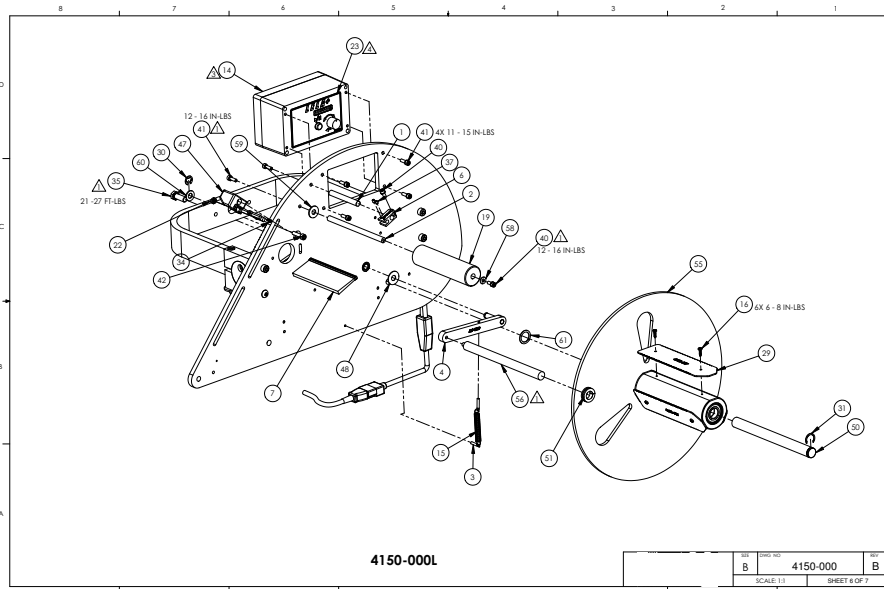

System Drawings

12.3 System Drawings - Peel Blade Exploded/Wear Items Kit

System Drawings

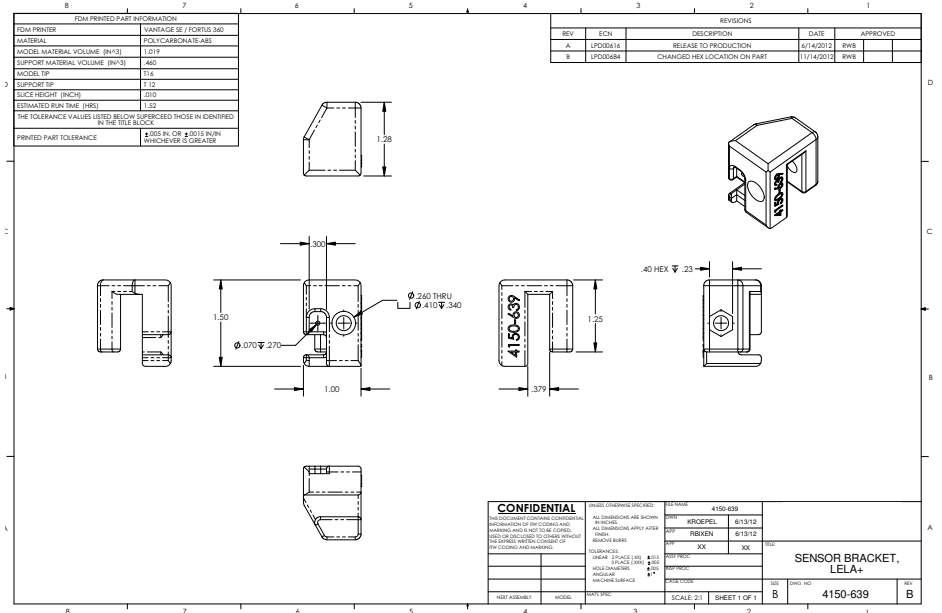
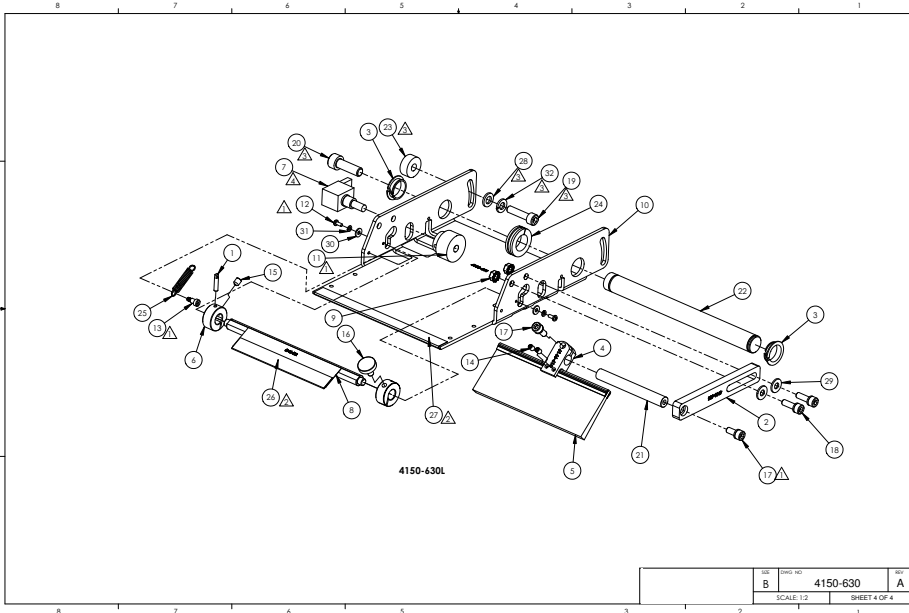
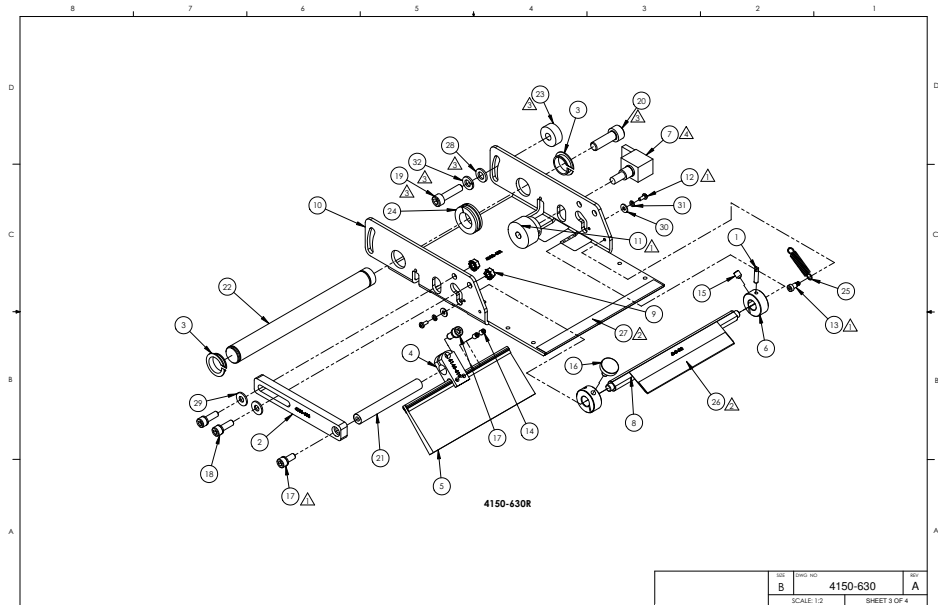
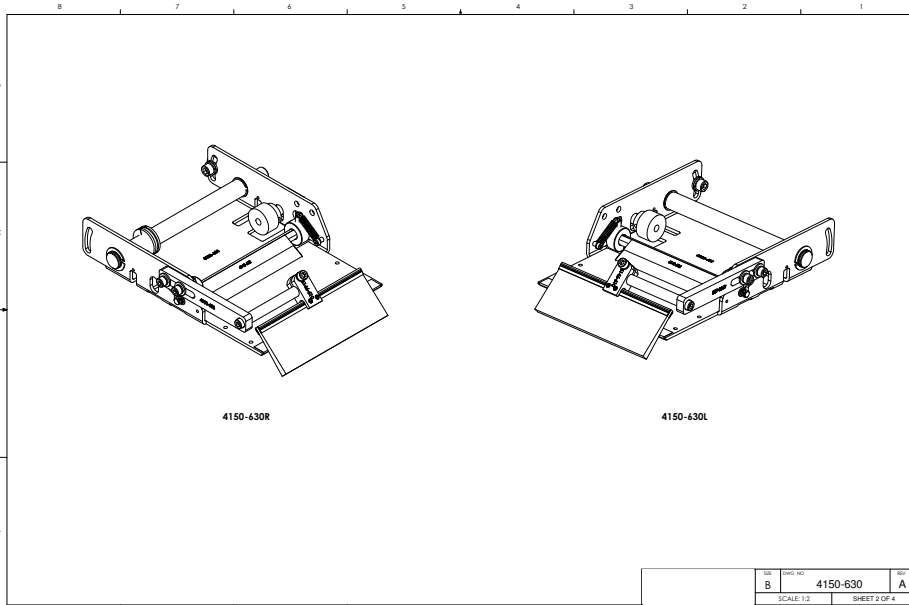

13.0 Declaration of Conformity



Declaration of Conformity

DECLARATION OF CONFORMITY

Illinois Tool Works hereby declares that the equipment specified below has been tested and found compliant to the following directives and standards-

Directives:

- EMC 89/336/ECC
- Low Voltage 73/23/EEC

Equipment Type:

Label Applicator

Model Number:

LELA+/LX500P HS/4150

Bruce Castro
 Director, Service Parts & Inks
 Diagraph, an ITW Company
 1 Missouri Research Park Dr.
 St. Charles, MO 63304
 USA

Standards:

- Conducted Emissions (EN55 011)
- Harmonics (EN 61000-3-2)
- Flicker (EN 61000-3-3)
- Radiated Emissions (EN55 011)
- Electrostatic Discharge (ESD) (EN 61000-4-2)
- Radiated Immunity (EN 61000-4-3)
- Fast Transient Burst (EN 61000-4-4)
- Surges (EN 61000-4-5)
- Conducted Immunity (EN 61000-4-6)
- Power Frequency Magnetic Field (EN 61000-4-8)
- Voltage Dips and Interrupts (EN 61000-4-11)
- Information Technology (EN60950-1:2001)

