

Marksman^{PRO}



High Resolution Printing
for the Real World

User Manual

2465-143
Revision H

for Software Version 3.1



Marksman Pro

Section 1: Introduction	1
Section 2: Safety	3
Section 3: System Components	5
Controller	7
Integrated Print Head	8
Marksman© Hub	8
Bracketry	9
Photosensor	10
Encoder	10
Ink	10
Waste Bottle	10
Section 4: Installation	11
Materials Required for Installation	11
System Installation Overview	12
Installing Bracketry	12
Mounting the Print System	13
Setting Up the Print Head	14
Mounting the Photosensor	14
Ship Caps	15
The Encoder	16
Electrical Cable Connections	17
Views	18
Priming the Print Heads	19
Manual Prime	19
APS Cycle	19
Controller and APS	19
Print Head Control of APS	20
Auxiliary Photocell Input	21
Section 5: Getting Started	23
Section 6: BoxWriter© Pro	25
Configuration	25
Production Line Configuration	25
Print Head Configuration	28
System Barcode Parameters	30
System Date/Time Codes	30
System Shift Codes	30
General Settings	31
Startup:	31
Security	32
Configure Users	32
Group Options	32
Login	34
Logout	34

Marksman Pro

Help	34
Translate	34
Operation	35
Operate Start Task	35
Operate Stop Task	35
Operate Database Start	35
Operate Idle Task	35
Operate Resume Task.....	36
Operate Edit.....	36
Test Pattern.....	36
Operate Change User Elements	37
Operate Change Counts.....	37
Operate Exit.....	37
View	38
View Print Report.....	38
View Scan Report.....	39
View Diagnostic Dialog	40
Preview	40
Refresh.....	40
Zoom.....	40
Section 7: BoxWriter© Pro Editor	41
Define	41
Boxes	41
Box Usage	42
Editor Defaults.....	42
Element Defaults	43
Backup Path.....	43
Custom Date/Time Formats	44
Date/Time Codes	47
Bitmap Editor	48
Label Editor	48
Shift Codes	48
Sub-Elements.....	49
Application Identifiers.....	51
Global Barcode Parameters	52
Tools	54
Files	54
New.....	54
Creating a Task.....	55
Open	56
Copy	57
Import	59
Export	60
Delete.....	60
Save As.....	61
Properties	61
Exit	62

Marksman Pro

Elements	63
Element Bar	63
Text.....	64
Bitmap	65
Count	66
Date / Time Element.....	67
Expiration	68
User.....	69
Shift	69
Barcode.....	70
Database	72
Serial.....	75
ToolBar	76
New.....	76
Open	76
Save	76
Save All	76
Cut	76
Copy	77
Paste.....	77
Undo	77
Redo.....	77
Zoom In	77
Zoom Out.....	77
Zoom Normal	77
Zoom Custom	77
Fit View to Screen.....	77
About	78
Font bar.....	78
Name.....	78
Size	78
Width	78
Rotation Bar.....	79
Alignment Bar	83
Perspective	86
Section 8: Maintenance	89
APS - Automatic Priming System	89
Shutdown Procedures	90
Section 9: Troubleshooting	93
Troubleshooting Notes	93
Troubleshooting Tests	94
Print Test	94
Photosensor Sensitivity Test.....	94
Print Quality Troubleshooting	95

Marksman Pro

Appendix A: Specifications	99
Controller Specifications	99
Print Head Specifications	100
Appendix B: Theory of Operation	103
The Marksman© Pro	103
Print Heads	103
Photosensor	103
Encoder	103
Wiring Diagram - Marksman Pro Rev A through K	104
Wiring Diagram - Marksman Pro Rev L & Higher	105
Appendix C: Parts and Supplies	107
Consumables	107
Controller Assembly Service Kits	107
Print System Service Kits	108
Appendix D: Testing the Electrical Outlet	109
Electrical Line Transients	109
Appendix E: Setting the IP Address	111
Setting the IP Address on the PC	111
Windows XP®.....	111
Windows 2000®.....	113
Windows 98®.....	115
Appendix F: Database Start	117
Description	117
Database Start Task Routine Flowchart	117
Database Lookup Definition - Global Setting	118
Database Start Task	119
Serial Port Modification	119
Printer Report Modification	120
Appendix G: Hand Scanner	121
Scan and Shoot Setup	121
Create a task	121
Scanner	122
Mask task name from a serial string:.....	123
Testing the Start Task.....	123
Appendix H: Fonts	125
Font List	125
Font Samples	126
Appendix I: Standard Operating Procedures	131
FJSOP1 - Removal of FoxJet High Resolution Printheads	131
FJSOP2 - Daily Maintenance for AMS/APS Printheads	133
FJSOP3 - Daily Maintenance for non-AMS/APS Printheads	135
FJSOP4 - Installation of FoxJet High Resolution AMS/APS Printheads	137

Section 1: Introduction

The Marksman© Pro is an advanced high-resolution ink jet controller that runs on a Microsoft Windows XP® platform. It includes a built-in keypad with a TFT display with touch-screen control. The Marksman© Pro can control up to 6 ProSeries high-resolution print heads for printing industry compliant barcodes, graphics or alphanumeric text on porous materials and cases.

This manual covers the operation of the Marksman© Pro Ink Jet Printing System, Marksman© Pro Controller, ProSeries Print Heads and Marksman© Hub.

Section 2: Safety

Following is a list of safety symbols and their meanings, which will be found throughout this manual. Pay attention to these symbols where they appear in the manual.



Wear safety goggles when performing the procedure described!



Caution or Warning! Denotes possible personal injury and/or damage to the equipment.



Caution or Warning! Denotes possible personal injury and/or equipment damage due to electrical hazard.



NOTE: (Will be followed by a brief comment or explanation.)

Only trained personnel should operate and service the equipment.



NOTE: It is extremely important to:

- Clean up all ink spills with the appropriate conditioners immediately and dispose of all waste according to local and state regulations.
- Wear safety glasses and protective clothing, including gloves, when handling all inks and conditioners.
- Store inks and conditioners under the recommended conditions found on the MSDS (Material Safety Data Sheet).



PRODUCT COMPLIANCE DISCLAIMER NOTE:

This product meets the requirements of CAN/CSA-22.2 NO.60950-00 * UL 60950 using FoxJet an ITW Company approved items. Units are only tested and qualified with FoxJet an ITW Company approved inks, parts and accessories. Use of other inks, parts or accessories may introduce potential risks that FoxJet an ITW Company can assume no liability for.

Section 3: System Components

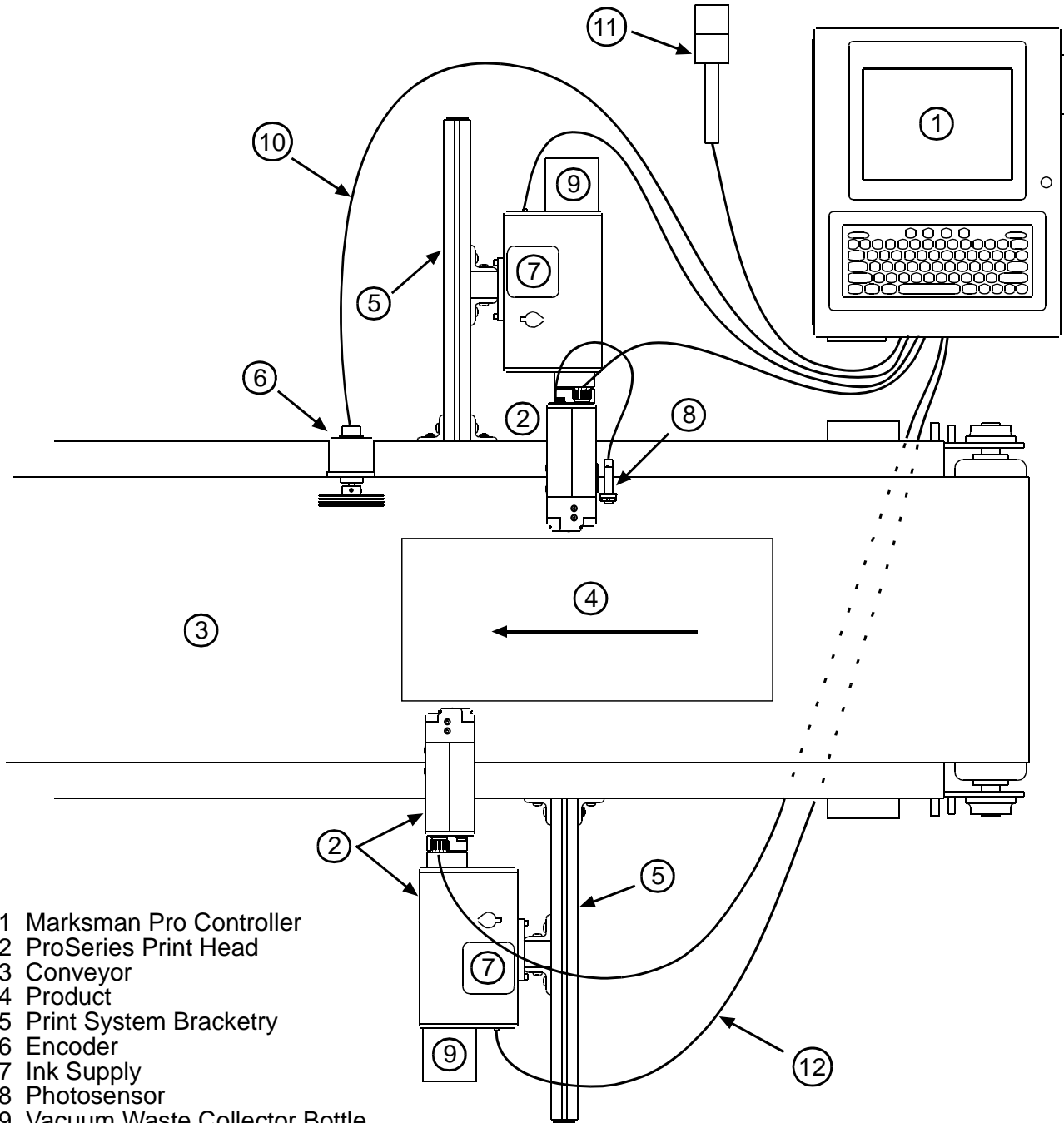

- 1 Marksman Pro Controller
- 2 ProSeries Print Head
- 3 Conveyor
- 4 Product
- 5 Print System Bracketry
- 6 Encoder
- 7 Ink Supply
- 8 Photosensor
- 9 Vacuum Waste Collector Bottle
- 10 Encoder Cable
- 11 Alarm Beacon (Strobe)
- 12 Cordset, APS Controller

The Marksman® Pro Ink Jet System is available with the following components, options and service kits:

Part Number Description

Integrated Print Head

2464008	ProSeries 192, Integrated w/APS, V300
2464023	ProSeries 192, Integrated w/APS, ScanTrue II®
2464009	ProSeries 352, Integrated w/APS, V300
2464034	ProSeries 384, Integrated w/APS, ScanTrue II®
2464236	ProSeries 384, Modular
2464025	ProSeries 768, Integrated w/APS, ScanTrue II®
2464232	ProSeries 768, Modular, Vertical Orientation, ScanTrue II®
2466025D	ProSeries NP192 Print System Assembly, Domestic
2466025E	ProSeries NP192 Print System Assembly, European
2466026D	ProSeries NP192 Modular Print System Assembly, Domestic
2466026E	ProSeries NP192 Modular Print System Assembly, European
2464228	ProSeries AlphaCoder, AlphaMark
2464238	ProSeries AlphaCoder, ScanTrue II®

Controller Assembly

2465000D1	Controller Assembly, ProSeries, Marksman® 1 Head, Domestic
2465000E1	Controller Assembly, ProSeries, Marksman® 1 Head, European
2465001D-IPC	Controller Assembly, ProSeries, Marksman Industrial PC, Domestic
2465211	PHC Upgrade Kit

Print Head/Controller Bracketry

2464550	Print Head Conveyor Mount Bracket
2464552	Retracting Bracket for 96/192 Print Head
2464553	Print Head Pivot Bracket
2464561	X-Y Axis Linear Adjustment, Tool-Less Bracket
2464562	Conveyor Mount/Roller Bracket for 768 Print Head
2464563	Print Head Floor Mount Bracket Kit
2464564	Conveyor Mount/Roller Bracket for 384/352 Print Head
2464565	Conveyor Mounting Bracket with Integrated Guide Rails for 384/768 Print Head
2465201	T-Base Controller Mounting Bracket Kit
2465219	Controller Conveyor Mounting Bracket Kit

Encoder, Photosensor, Alarm Beacon

2465224	Photosensor, ProSeries
2465223	Alarm Beacon (Strobe)

Cabling

2464182-010	Cable, Straight Thru, DB9, 10 Ft.
2464182-025	Cable, Straight Thru, DB9, 25Ft.
2464182-050	Cable, Straight Thru, DB9, 50 Ft.
2465155-010	Cable Kit, Print Head, DB25, 10 Ft.
2465155-025	Cable Kit, Print Head, DB25, 25 Ft.
2464312	Cable, APS Photocell Networking ("Y" Cable for sharing Auxiliary Photocell)

Controller

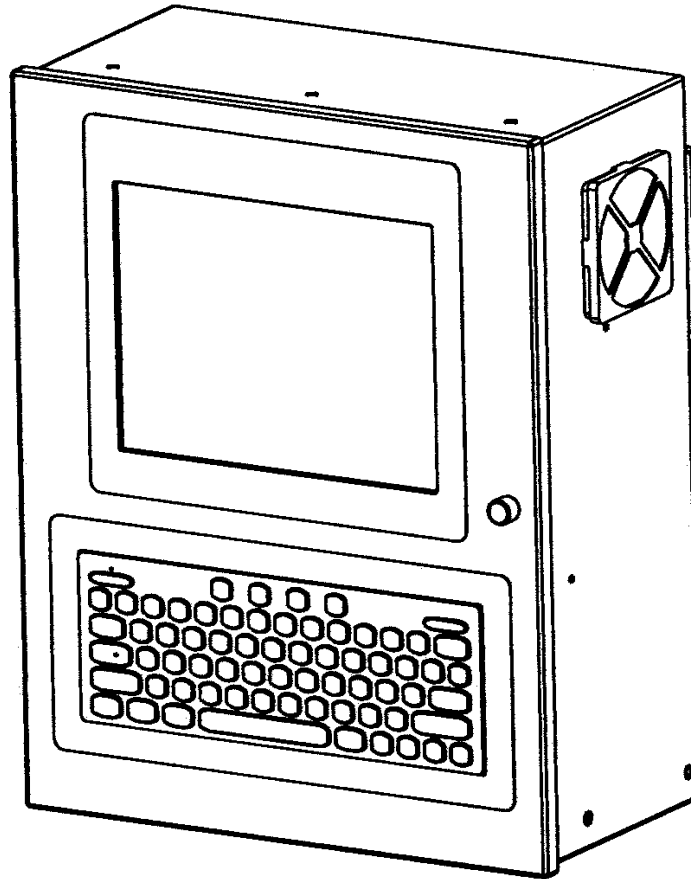

Integrated Print Head

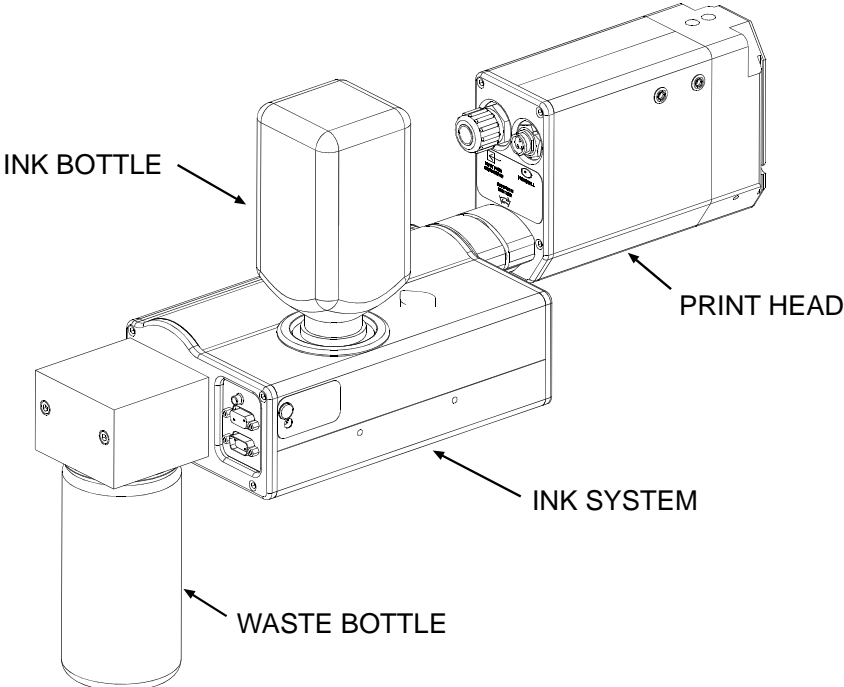

Marksman© Hub

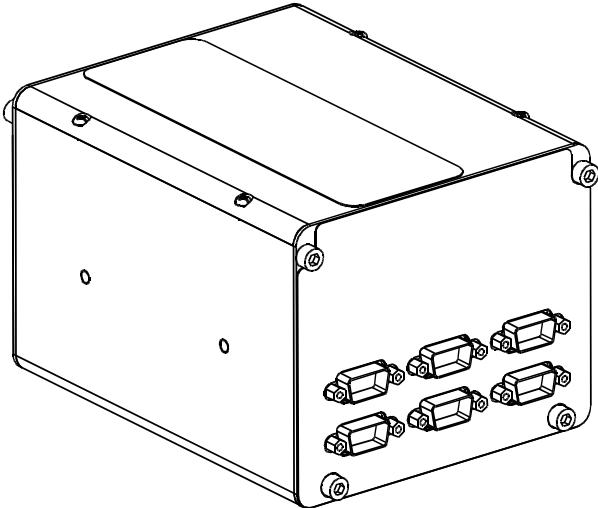

Bracketry

Bracketry is the structure that supports the controller, print system and other accessories. This manual details instructions for mounting all system components to a conveyor. Other mounting options for the controller and print system include the floor mount and the retracting bracket. Assembly instructions are included with parts kits.

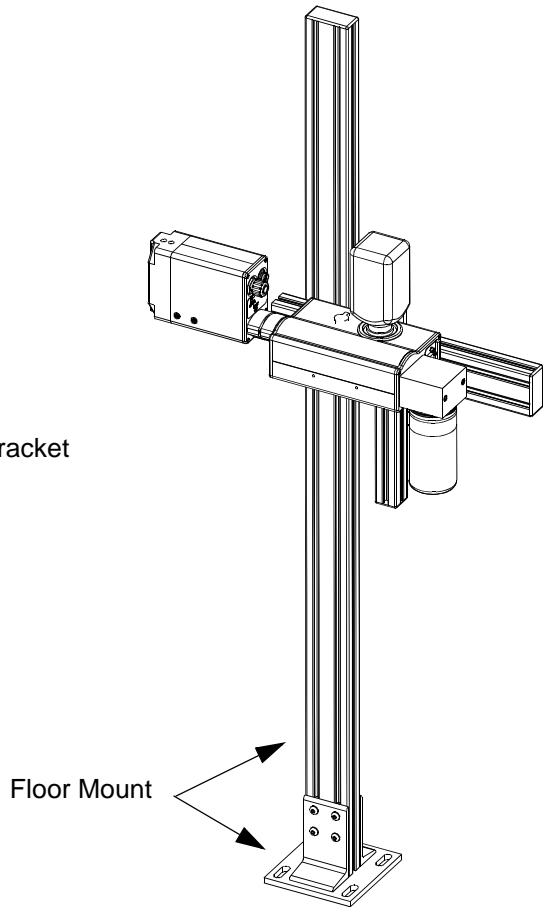
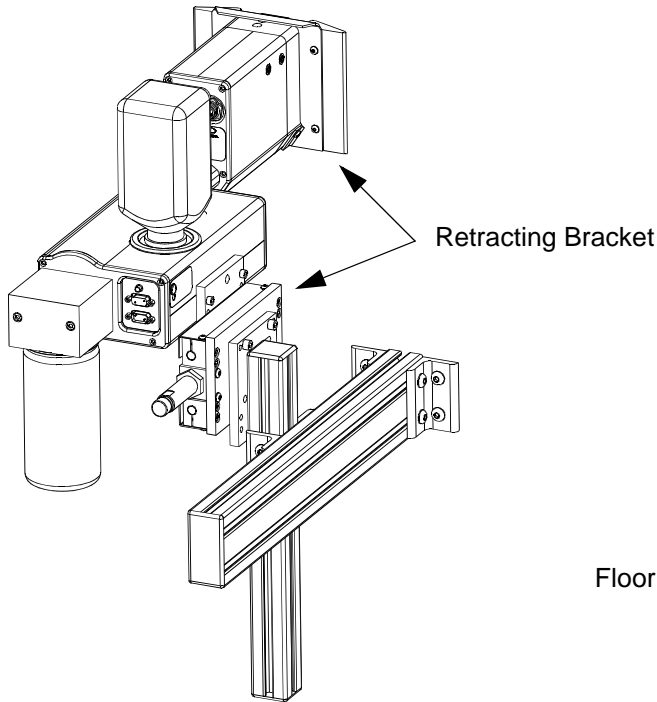
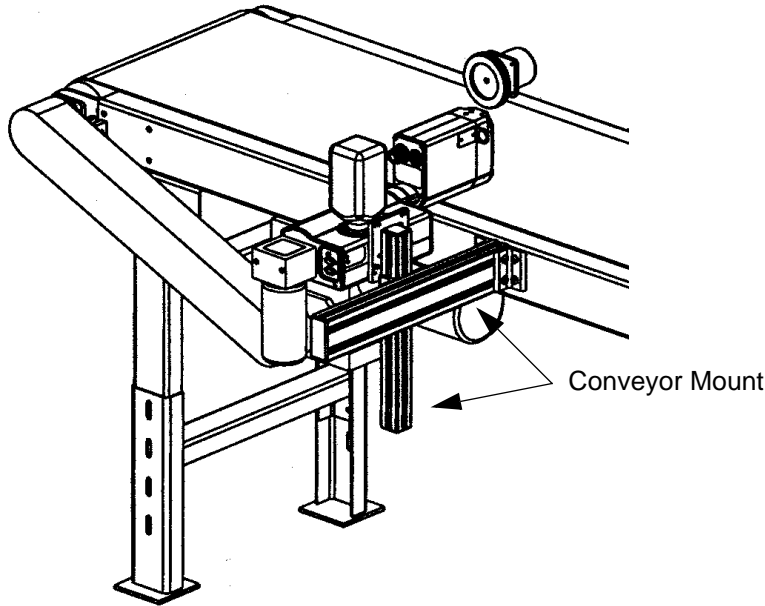

Photosensor

The photosensor is both a light source and a sensor. It emits light and detects the arrival of a product when the product reflects the light source back to the sensor. The sensor then sends a signal to the controller to start the printing cycle.

Encoder

The encoder assembly provides conveyor line speed information to the controller. It also allows automatic disabling of printing when the line stops.

The Marksman® Pro System uses a 5000 ppr open collector output encoder. The wheel is sized to provide the correct timing inputs to allow the print heads to print from 150 to 300 dpi.

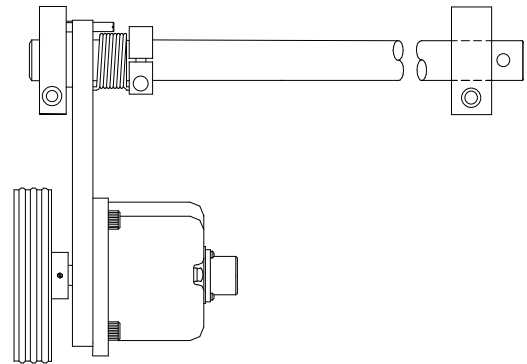

ENCODER ASSEMBLY

Ink

Ink is supplied via 500 mL plastic containers. Ink types include glycol-oil based VersaPrint™ V300 for general purpose printing and ScanTrue® II pigmented ink for high edge definition printing. Both inks are formulated for use on porous substrates.



NOTE: Check the label on the Print Head for correct ink type.



NOTE: VersaPrint™ V300 and ScanTrue® II inks are not miscible. Do NOT mix the inks.

Waste Bottle

The APS includes a Waste Collection Bottle mounted on the rear of the Print Head assembly. This bottle must be changed when full to prevent improper operation of the system. Instructions for waste disposal are on the collection bottle.

Section 4: Installation

The figure below illustrates a typical conveyor-mounted installation. (Cables are not shown.)

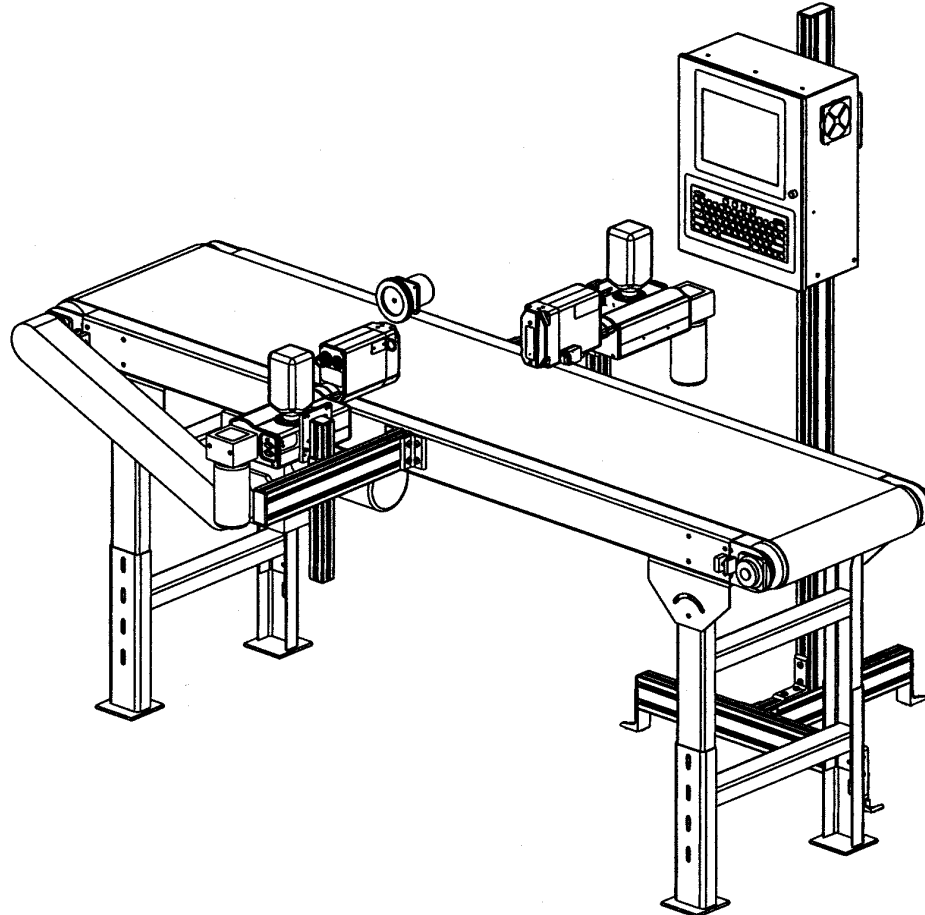

Materials Required for Installation

You will need the following items:

- Lint-free wipes
- Safety goggles
- Level
- Tape measure

Use appropriate safety equipment and procedures. Leave print heads in their shipping cartons until all bracketry is in place and tightened down.

System Installation Overview



NOTE: The following steps give an overview of the procedure to properly install the Marksman© Pro print system. Refer to the appropriate section for details.

1. Carefully plan the mounting location of the equipment. Keep in mind bracketry hardware location and printer equipment size.
2. Remove equipment from packaging.
3. Assemble all bracketry to the floor, conveyor, or other bracketry per bracketry installation section.
4. Mount the print system to its appropriate bracketry. Do not connect to power outlet.
5. Assemble the optional retracting bracket to each print head, if applicable.
6. Mount the print head(s) to their appropriate bracketry and in the approximate location relative to the carton.
7. Mount the photosensor, optional bracketry, and optional encoder per procedure.



CAUTION: Remove the print head Ship Cap prior to operating the Print Heads.

Installing Bracketry

This section shows controller bracketry mounted to a conveyor. This is the most common mounting method, and the most stable, as all bracketry is bolted directly to the conveyor. Detailed assembly instructions are included with the parts kit.

Other mounting options, including parts kit numbers, are listed in *Section 3, System Components*.

Corner brackets are attached to aluminum bars as shown.

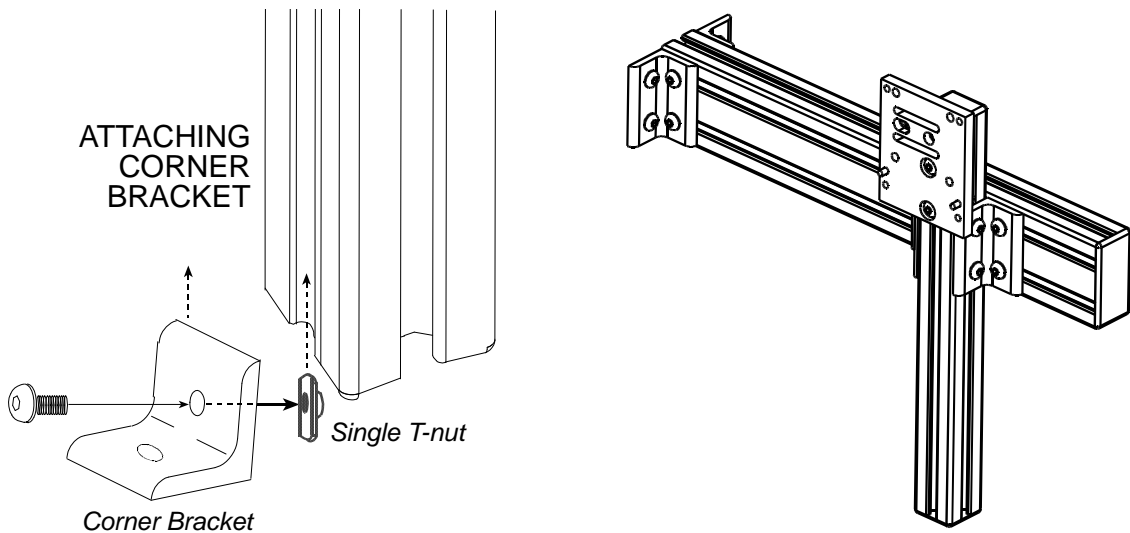

Mounting the Print System

Unpack the print head just before mounting to the bracketry.

Attach the print head to the bracketry with a print head mounting bracket.

The print head must be mounted in close proximity to the product. To maintain consistent print, the head should be mounted no more than 1/8" from the substrate. An optional retracting bracket is available to mount the head and control the distance from the head to the substrate. The retracting bracket allows the head to bump the product and retract as required to maintain a consistent throw distance. (See *Section 3, System Components* for bracketry options.)



NOTE: Install optional retracting bracket kit on the print head prior to mounting the print head to the conveyor bracket.

It may be necessary to vertically adjust each bracket's horizontal bar later to fine-tune message placement. This is especially true when using multiple print heads, as message lines will need to be synchronized with each other.



NOTE: When adjusting the horizontal bar or print head mounting bracket, always support the print head with your hand to keep it from falling forward onto the conveyor.



NOTE: The ProSeries print heads work on gravity and capillary ink feed, internal in the print head. The head must be mounted in a level position from front to back to prevent leakage.

Setting Up the Print Head

The Pro/Classic Series print heads are mounted using the 10-32 tapped holes on the right or left side of the Ink System bottom case. The print head angle can be set between 0° and 90°. Common settings are shown below.

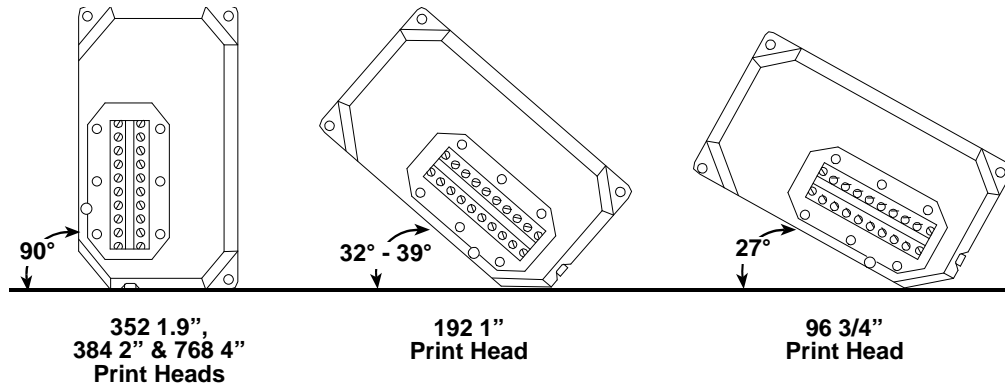

To adjust the head to its correct angle:

1. Loosen the two set screws (1/8" hex head) on the print head side of the head mount.
2. Rotate the head to the desired angle.
3. Secure the set screws.

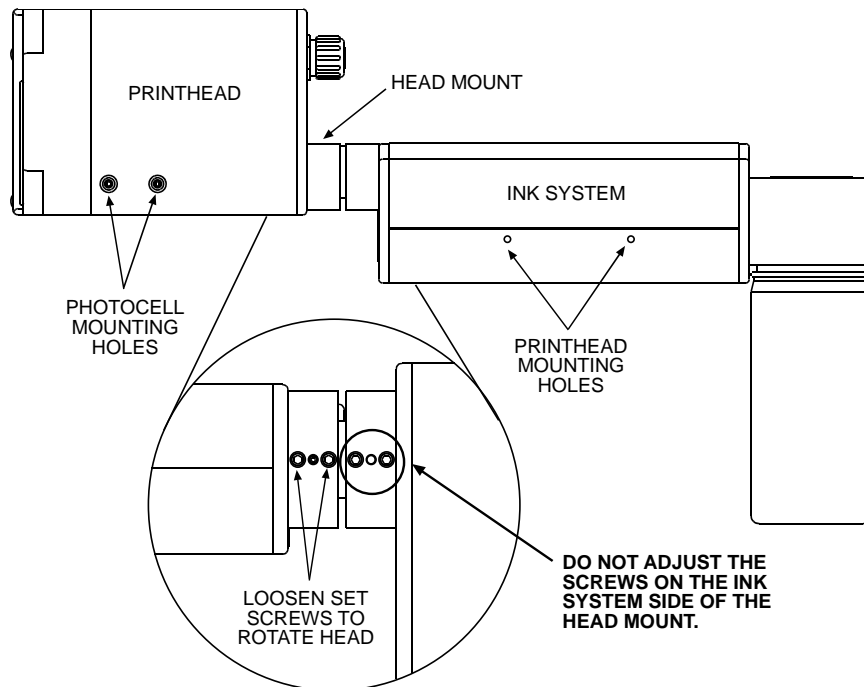

Mounting the Photosensor

The product detect Photocell can be mounted on either side of the print head, depending on the direction of print. Remove the plugs or set screws (3/32" hex head) in the photocell mounting holes, then attach the Photocell Mounting Bracket with the 10-32 x 1/2" screws provided with the bracket.

Ship Caps



CAUTION: Do not operate APS Print Heads with the Print Head Ship Cap installed! Operating a closed system can cause a siphoning effect which can drain the ink supply.

96, 192 and 352 Print Heads:

Remove the Print Head Ship Cap by squeezing the front of the side extensions together until the back releases. (See illustration at right.)

When replacing the Print Head Ship Cap, take care to align the rubber tips on the back of the cover with the rub buttons on the face of the print head.

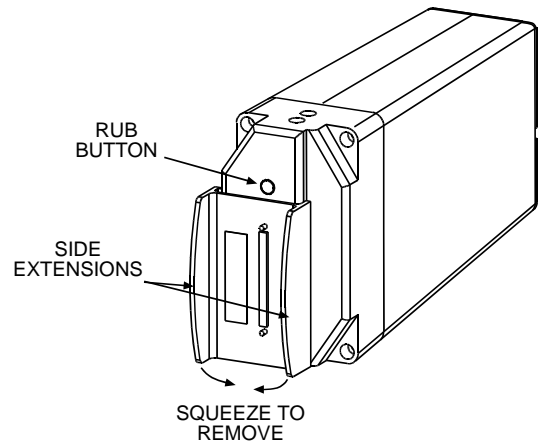

384/768 Print Heads

Loosen the two thumbscrews and remove the Ship Cap. (See illustration at right.)

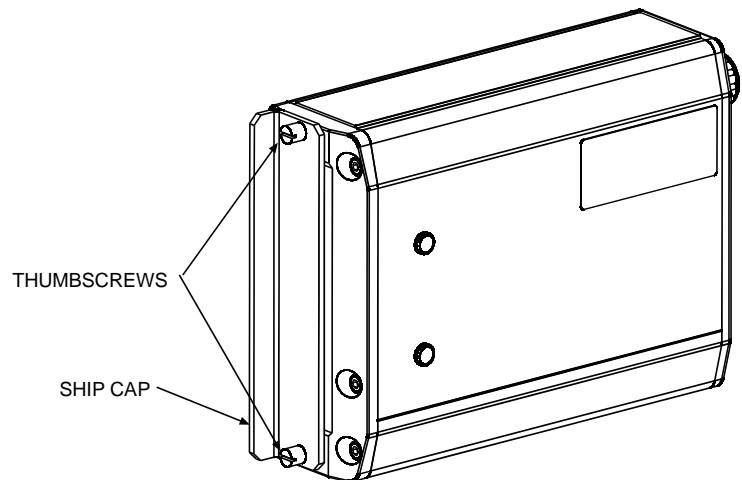

NOTE: If you place the Print Head Ship Cap on a hot print head and do not fasten it securely, the print head will weep ink until the head has cooled down.



NOTE: Ink may accumulate behind the ship cap during shipping.

Open the Reservoir Vent Cap and Install the Filter. Remove the Reservoir Ship Cap and Install the Ink Bottle. Save caps in a zip-lock bag for future use.



CAUTION: Do not over-tighten the ink bottle when screwing into the Reservoir. Over-tightening will damage the Reservoir.

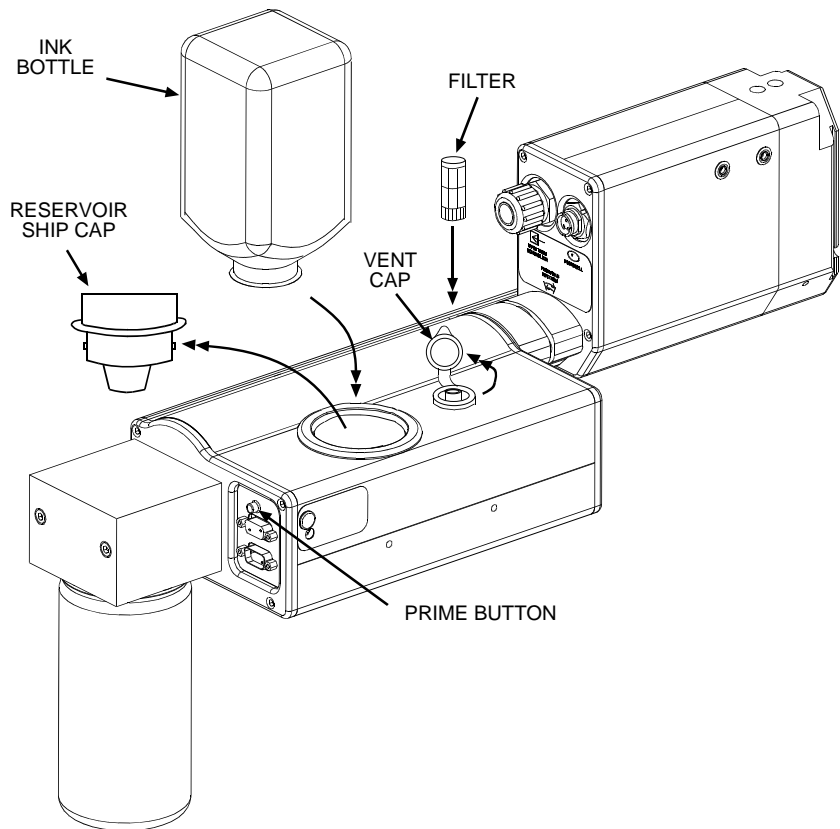

The Encoder

The encoder uses a wheel that rolls against the conveyor line to track the speed. It sends a signal to the controller, which makes adjustments for reported changes in the line speed.

It is not necessary to install the encoder immediately adjacent to the print heads. It is more important to place it where it will accurately measure the speed of the conveyor. Install it in contact with the conveyor, or with a wheel or roller moving the same speed as the conveyor.

The encoder's mounting bracket is spring-loaded. Adjust the spring collar to ensure that the encoder maintains stable contact with the conveyor.

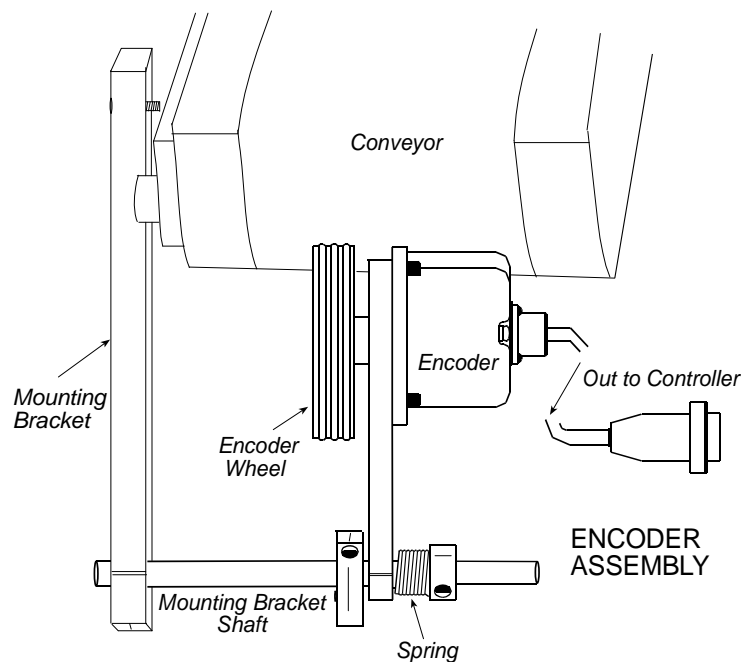

CAUTION: Do not jam the encoder wheel against the surface of the conveyor. A radial force of over 40 lbs. will reduce the life of the bearings.

Electrical Cable Connections

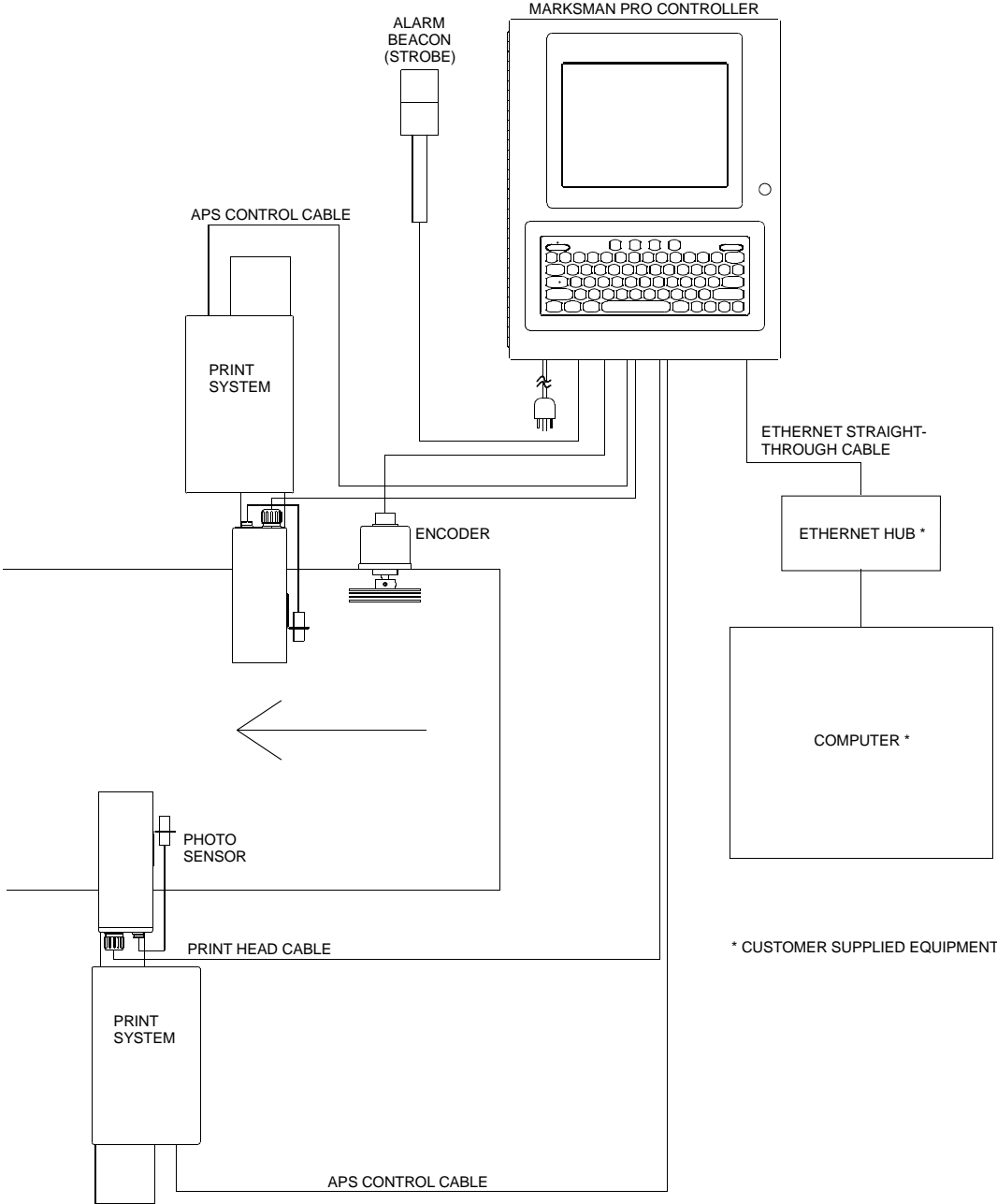

Views

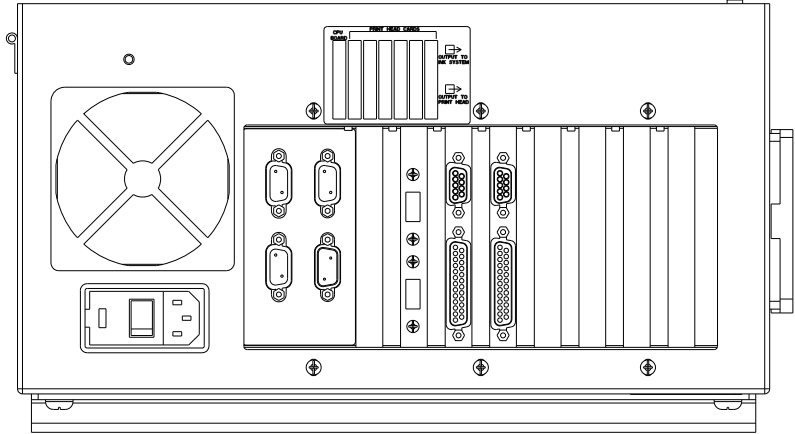

BOTTOM VIEW OF CONTROLLER

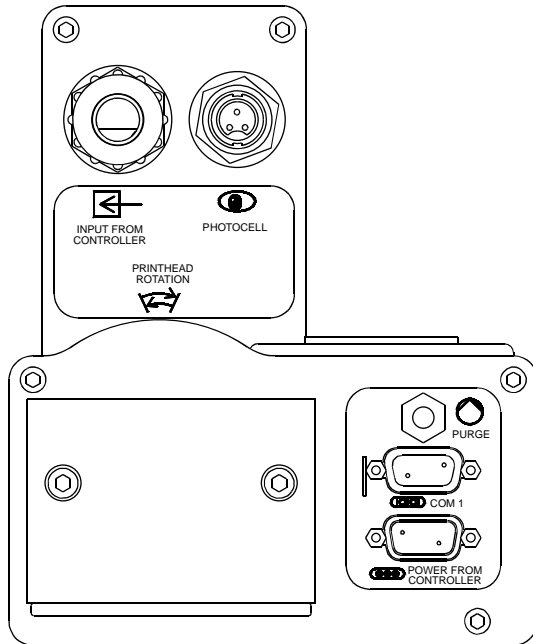

BACK VIEW OF PRINT SYSTEM

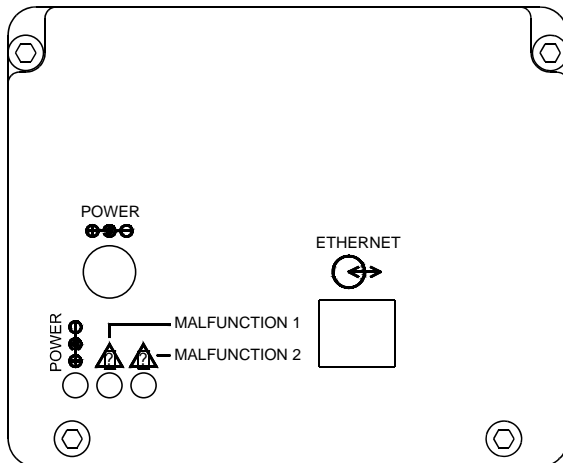

FRONT VIEW OF MARKSMAN HUB

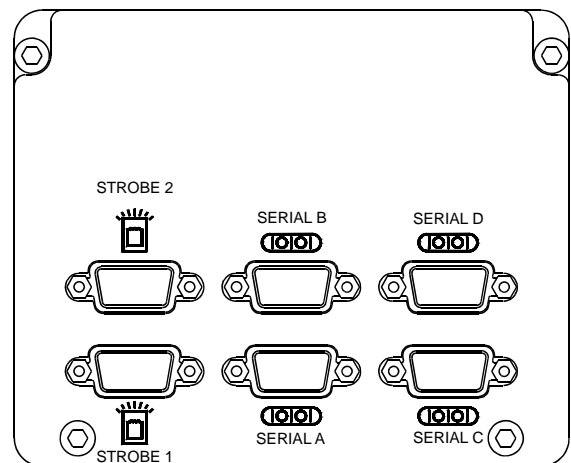

BACK VIEW OF MARKSMAN HUB

Priming the Print Heads



NOTE: The system will not prime either manually or automatically if there is a low ink indication. Low ink indication is caused by either low ink in the reservoir or full ink in the waste collection bottle.

Manual Prime



NOTE: Place a wipe in front of the maintenance plate to catch excessive ink.

A manual prime can be accomplished by depressing the push-button switch on the rear of the ink system housing. Pressing and holding the button for longer than one second will start the pump for a manual prime. It will continue to run as long as the button is depressed, or up to five seconds. If additional priming is required, release and press the button again.

Pressing for less than 0.5 seconds will initiate a maintenance cycle. If the system has started a maintenance cycle and the button is pressed, the manual prime will not operate. (The Priming Sequence and the Vacuum Cycle are less than 10 seconds long.)

APS Cycle

The APS (Automatic Priming System) cycle is a means for re-priming channels in the head if some are missing. The APS system does this by using a priming pump to force ink out of the channels and a vacuum pump and collection bottle to collect the ink waste. The APS cycle can be manually started by momentarily pressing the prime button.



NOTE: The system may not print during an APS cycle or manual prime.

Controller and APS

The APS (Automatic Priming System) cycle is controlled by BoxWriter when the APS cable is attached from each print head back to the controller. When the APS cable is attached to the print head, APS cycles will be performed as scheduled by BoxWriter. If a scheduled APS cycle is due, the software will wait until the system is not printing before performing the APS cycle. When the system starts an APS cycle, it locks out printing and must wait until the APS cycle is complete before it is able to print again. This may mean that some boxes will be missed. If this is a concern, it is recommended that the APS be controlled by the Print Head with the use of an auxiliary photocell.

Print Head Control of APS

Print Head control of the APS (Automatic Priming System) cycle is accomplished by a programmed timing interval set by the user at the print head (each head, if more than one is used). It can be set to run as often as necessary, from once every 2 hours to once every 18 hours for the UJII heads; or from once every hour to once every 12 hours for the graphic heads. The default setting is once every 4 hours (Switch Setting 2 for a UJII head or Switch Setting C for a graphics head). The interval can be adjusted by means of a rotary switch (Programmable Timer) mounted on the APS Controller PCB. (See the illustration below.) See the following Table for the hour interval for each setting of programmable timer.

0= No APS	UJII Heads									Graphics Heads						
Switch Setting	0	1	2	3	4	5	6	7	8	9	A	B	C	D	E	F
Interval (Hours)	0	2	4	6	8	10	12	14	16	18	1	2	4	6	8	12

Timing Interval Settings

The priming sequence will perform three separate consecutive primes of approximately four milliseconds each. The required time for the priming sequence is less than five seconds, with an additional 20 seconds for the vacuum cycle. As with previous Trident print-heads, printing cannot occur during the priming sequence.

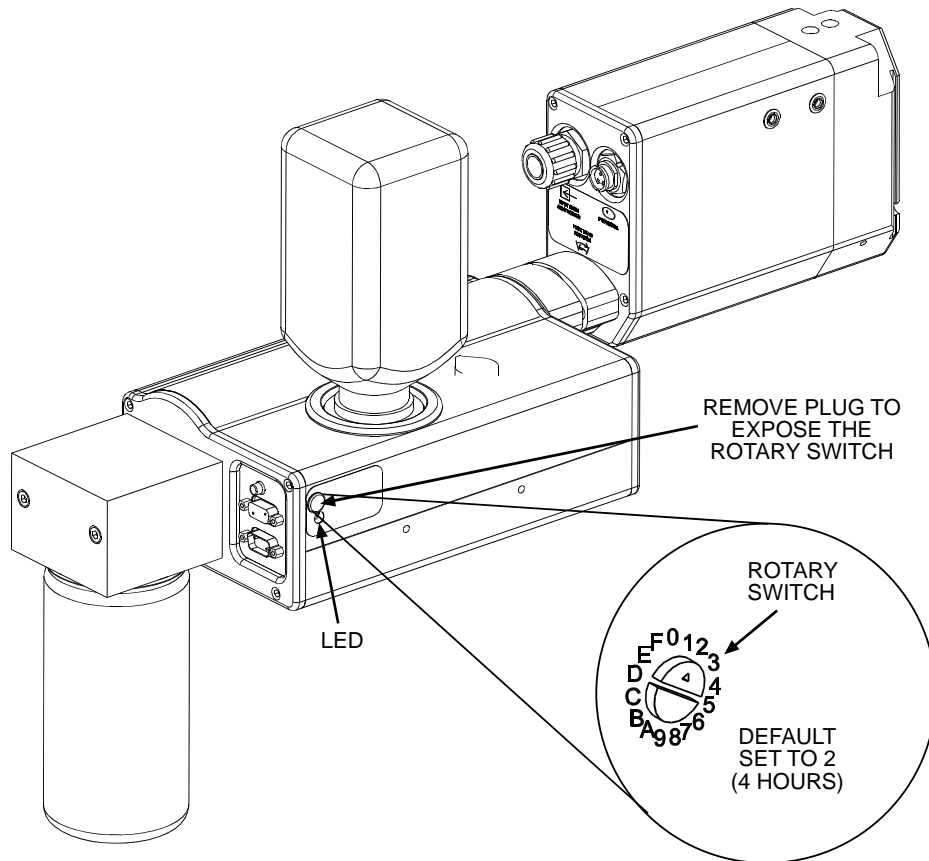

APS View for Pro/Classic Series Printheads

Auxiliary Photocell Input



NOTE: The APS Control Cable and Auxiliary Photocell cannot be used together.

An Auxiliary Photocell input is available to insure a print cycle is not missed during the automatic priming sequence. Connecting the Auxiliary Photocell will retard a prime sequence until there is enough time to complete the sequence without missing a print cycle. The default delay setting is three (3) seconds after the product passes the photocell. Multiple heads can share the Auxiliary Photocell by using the Photocell "Y" Cable. To change the default setting, perform the following steps:

1. Insure that the rotary switch is not in the "0" position.
2. Place a box in front of the photocell.
3. While the photocell is on, set the rotary switch to 0.
4. When the LED stays illuminated continuously, set the rotary switch to a new number (1 through F) representing the number of seconds (1 through 15) you want to delay. **Note:** "0" is not an available user setting.
5. Press and hold the Prime button until the LED starts flashing.
6. Release the Prime button.
7. Remove the box from in front of the photocell.
8. Set the rotary switch back to the desired hour setting.

Section 5: Getting Started

The Marksman® Pro printer is a standalone unit capable of operating from one to six Marksman® Pro print heads. The main dialog for the print control application is shown below:

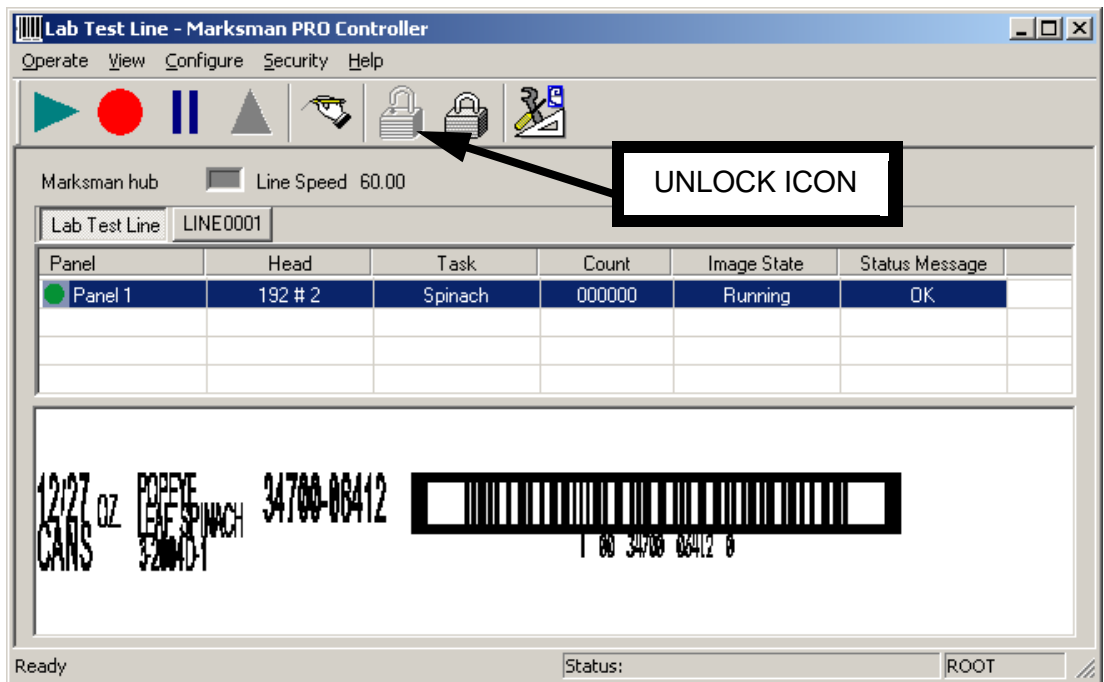

To log on, click the "Unlock" icon, then enter the Username and Password. (Note: Usernames and passwords are not case sensitive.)

Username: ADMIN

Password: FOXJET

The menu tree at right shows all the menus and sub-menu options available from within the control application.

Menu options are configurable and may be unavailable for operators with limited access. The operator must have administrative privileges to access all menu options.

The operator may also use the tool bar for quick access to the **Start**, **Stop**, **Idle**, **Resume**, **Edit**, **Logout** and **Login** menu selections.

Marksman® Hub: A green icon indicates that the device Hub is connected; a red icon indicates that the device Hub is not connected; a gray icon indicates that the Hub is disabled.

Line Speed: The line speed indicates the distance traveled on the production line in feet per minute.

MARKSMAN PRO MENU TREE:

- Operate
 - Start
 - Database Start
 - Stop
 - Resume
 - Idle
 - Print Test Pattern
 - Edit
 - Change User Element
 - Change Counts
 - Exit
- View
 - Printer Report
 - Scan Report
 - Diagnostic Dialog
 - Preview
 - Refresh
 - Zoom
- Configure
 - Database
 - Print Heads
 - Production Line
 - System
 - Barcode Parameters
 - Date/Time Codes
 - Shift Codes
 - General Settings
 - Output Table
- Security
 - Users
 - Group Options
 - Login
 - Logout
- Help
 - About
 - Translate

Production Line: The production line name is selected and viewed by selecting the tabbed folders. The production line configuration provides for a means of grouping print heads. Up to two production lines can be created and configured.

Panel: The panel name indicates a specific side of a rectangular cube representing the product container. Each of the six panel names may be utilized to aid in describing the physical location of a print head in relation to the product.

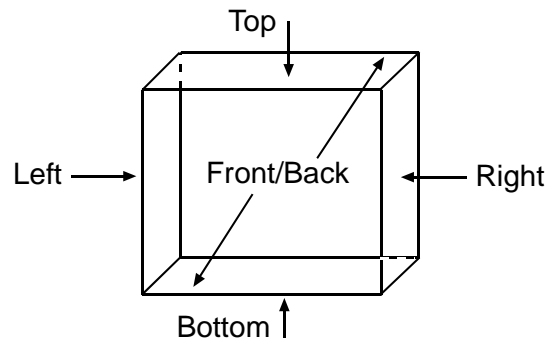

Head: The print head name indicates a user-defined alphanumeric name associated with a physical print head. Up to six print heads may be defined. Each print head name must be unique to the system.

Task: A task refers to one to six panels that are to be printed together as a label.

Count: The count indicates the number of times that a task has been printed.

Image State: The image state indicates the current image status for a task. The Image State may be Running, Paused, Idle or Stopped.

Status Message: The status message displays messages pertaining to the print head status. A status message may include one of the following:

Green Strobe Light

OK - No Faults

Red Strobe Light

Ink Low - Ink bottle needs to be replaced

Red Flashing Strobe Light - **Controller will not print**

Ink Out - Reservoir at the print head is out of usable ink. Replace ink bottle.

Voltage Error - The controller is not detecting any high voltage at the print head.

Low Temp - Print head is not at operating temperature.



NOTE: The system will not print if the controller is reporting a Low Voltage Error, Out of Ink condition or Low Temperature condition. If a strobe is connected to the system, this is represented by a flashing red light.

Status Line: The status line is used to display other system messages and system status. The name of the user currently logged in is also shown.

Section 6: BoxWriter© Pro

Configuration

Production Line Configuration

The production line configuration allows for grouping of settings that relate to a particular setup. Select **Configure**, then select **Production Line** from the menu. To edit a line, select it and click **Edit**; or double-click the line.

Add: The Add button allows for the addition of another production line, for a maximum of two production lines.

Delete: The Delete button allows for the removal of a production line from the configuration. All messages/tasks created for this production line will be deleted.

Description: The description field is used to help define the production line.

Coupled: If this field is checked, starting a task on one line will also start it on the other. The same is true for Stop, Idle and Resume. Note that you must have two lines configured to use this feature.

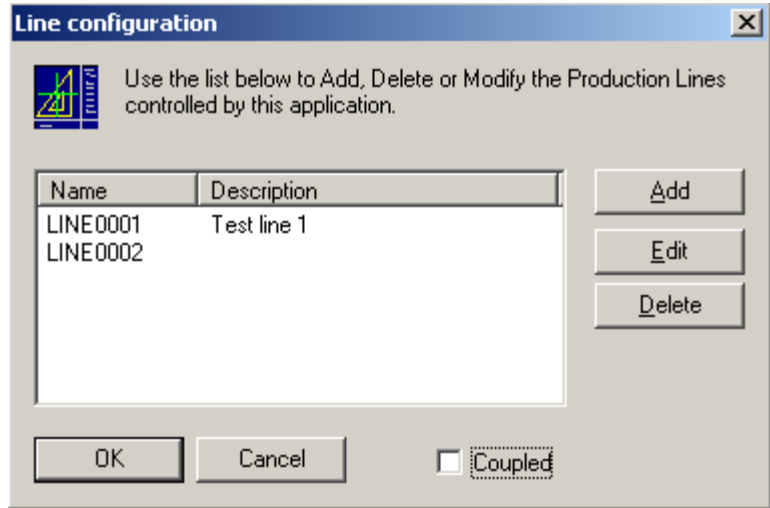

Fixed Scanner

This group defines the parameters for a fixed scanner that may be connected to the Marksman© Hub. The data is stored under the Scan Report (see *View Scan Report* later in this section).

No Read String: The No Read String must match the No Read string that is transmitted from the fixed scanner.

Consecutive No Reads: The Consecutive No Reads field is used to perform a quality check on barcodes that are printed. This value determines the maximum number of consecutive No Reads that may be transmitted by a fixed scanner. The printing will be stopped upon reaching the maximum value.

Serial Download Port: Please select the port to be used to send the data out if it is required to be transmitted to a device at the start of each task. The data is entered through the Editor Task properties.

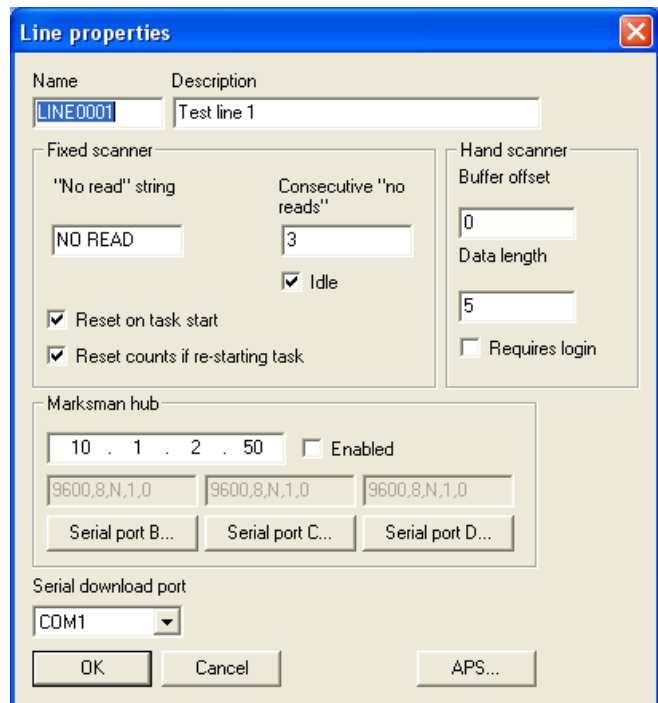

Reset on Task Start: The Reset on Task Start check box determines that the current number of consecutive No Reads will be reset to zero upon a task start operation.

Scan & Shoot requires login: Requires the operator to login before the hand scanner can be used to select a new task.

APS Settings: Interval (hours) is the interval in hours at which the heads on the production line will perform an APS function. (The other settings listed are for information only.)

Disable: Will prevent the controller from automatically performing an APS.

32 Channel Heads				256 Channel Heads			
A1	3	A5	2500	A1	3	A5	5500
A2	1000	A6	3	A2	1000	A6	2
A3	10	A7	20	A3	28	A7	100
A4	1000			A4	1000		

Do not change these values

Interval (hours)

Disable

OK Cancel

Hand Scanner

This group defines the parameters for parsing the data stream transmitted by a hand scanner. The data transmitted by the hand scanner must contain a valid task name in order to allow the task to start.

Buffer Offset: The Buffer Offset value determines the number of characters to offset into the buffer as transmitted by the hand scanner.

Data Length: The Data Length value determines the number of characters to extract from the data buffer that will form a task name.

Marksman© Hub:

The Marksman© Hub may be connected to the Marksman© Pro through a TCP/IP connection. The device provides additional interface methods such as serial ports. A proper IP address must be entered and the Enabled field selected to connect to the device. The main dialog screen will display a green LED when communicating with the device.

IP Address: The IP Address dialog contains the IP address of the Marksman© Hub.

Enabled: The Enabled button determines if a connection to a Marksman© Hub should be attempted. Click the button to toggle the option between enabled and disabled.

Serial Port: Select the appropriate button to edit the setup parameters for a serial port on the Marksman® Hub. The available properties for the serial ports are shown in the Serial Settings dialog box.

Each of the properties may be selected using the corresponding drop-down menu choices. When selections are complete, click **Apply**. The default selections are shown in the screen at right.

Baud: The Baud option determines the speed of the transferred data and may be set to 9600, 19200, 38400, 57600 or 115200.

Parity: Parity determines the type of parity bit to be used. It may be set to None, Odd or Even.

Data Bits: Data Bits determines the number of data bits used. It may be set to 7 or 8.

Stop Bits: Stop Bits determines the number of stop bits to be used: 1, 1.5 or 2.

Device Type: Select what the serial port is to be used for:

Task Start - Serial device used to select/start a task, generally a hand scanner.

Barcode Verification - Fixed scanner used to read each barcode after it is printed.

Variable Data: Data to be printed imported through the serial port.

Host Interface: Remote control of the Pro through the serial port.

Line Usage: Associates a line to the serial port.

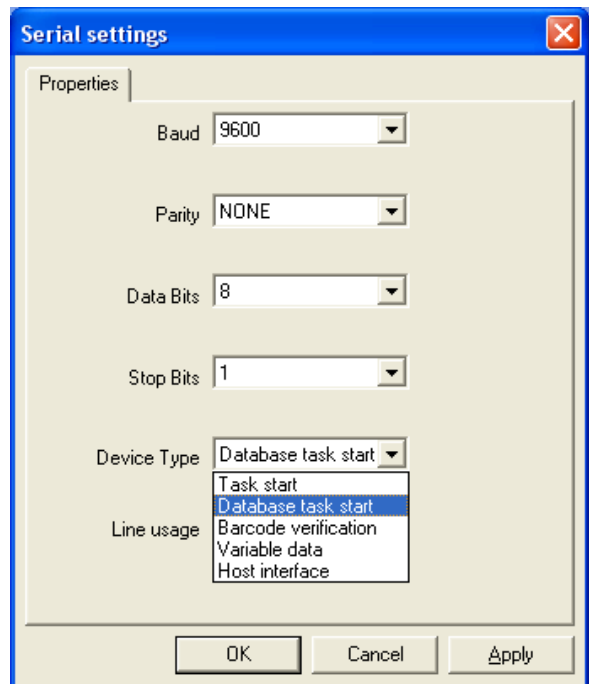
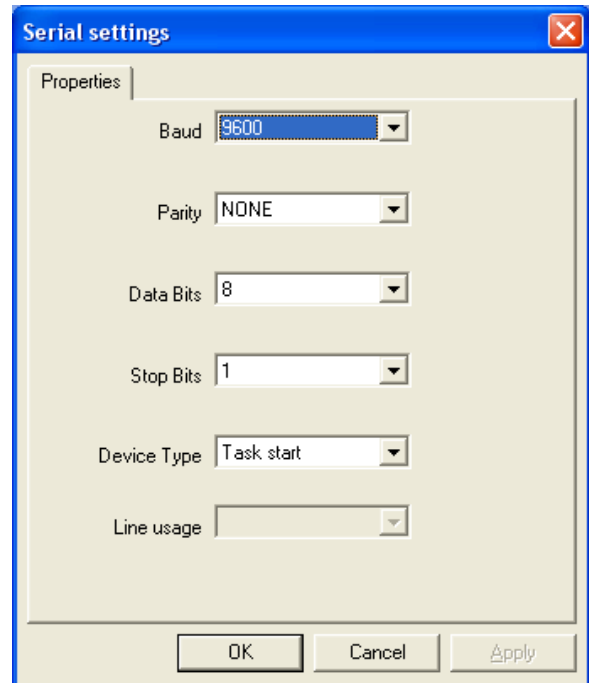

Print Head Configuration

Select **Configure**, then select **Print Heads** from the menu. Select a panel and click on a head. A head may be added or removed by clicking the appropriate Add/Remove button. To edit a head, select it and click **Edit**; or double-click it.

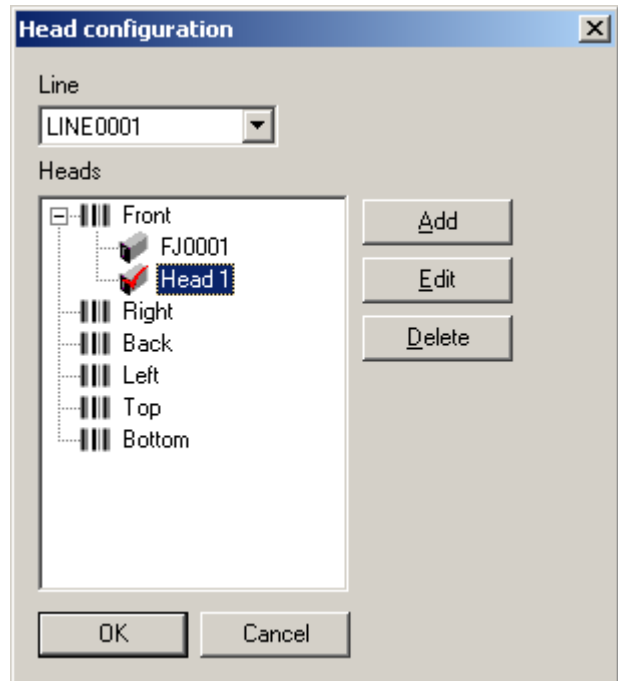

Name: The head's user-defined name.

Panel: The panel which the head will print on.

Encoder Resolution: Can be set to either 426dpi or 300dpi. Please check the resolution of the encoder wheel being used. **NOTE:** The default dpi-setting of the ProSeries96 and the NP192 is 300dpi if a 300dpi encoder is used, or 213dpi if a 426dpi wheel is used.

Type: Select a head type from the drop-down menu list.

Angle: Select the angle of the head with respect to the conveyor. Each head type has a set of mounting angles that are selectable.

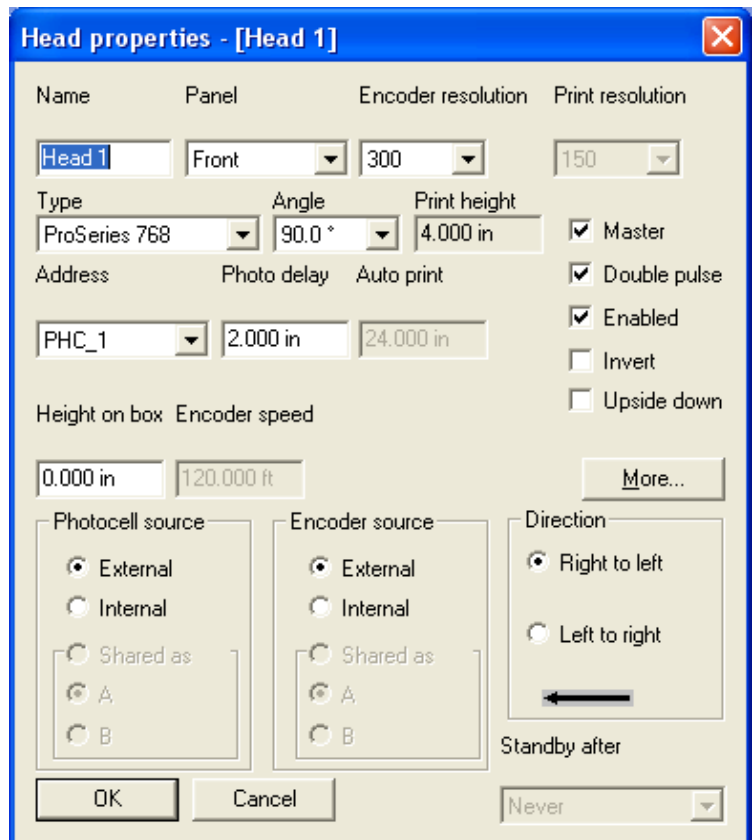

Print height: The print height is the maximum print coverage of a single print head at a selected angle.

Master: Each line must have a master head. The master print head receives/distributes the signals for the photocell and encoder to the remaining heads. Only one controller may be selected as the master print head.

Address: The address of the slot where the PHC card for this head is plugged in to. The first head installed on the system should always be in the first slot (PHC_1). Subsequent heads should be added in the next available slot (i.e., PHC_2, then PHC_3.). Do not skip an address.

Photo delay: Photo Delay is the horizontal distance (in inches) measured from the photocell to the print head.

Auto print inches: If internal photocell is selected, this number indicates the length of the message to be printed. For example, if it is set to 36, the internal photocell will fire once for every 36 inches of travel of the conveyor, as indicated by the encoder.

Height on box: The vertical distance in inches measured from the lower part of the product or conveyor to the print head nozzle zero.

Encoder Speed: The desired internal encoder speed measured in feet per minute. The default is 60 feet/min.

Photocell source: Indicates whether the photocell is external or internal. The photocell signal from another head may also be used (shared). [See *Guidelines for Sharing* below.]

Encoder source: Indicates whether the encoder is external or internal. The encoder signal from another head may also be used (shared). [See *Guidelines for Sharing* below.]

Guidelines for Sharing:

PHC_1

- Must always be the master head.
- Can use encoder A and photocell A only, cannot use photocell or encoder from any other head.

PHC_2

- Can use encoder B and/or photocell B.
- Can use encoder A and/or photocell A, but must be shared from PHC_1.

PHC_3, PHC_4, PHC_5, PHC_6

- Can use encoder A or B and photocell A or B, but must share from another head.

Direction: The direction of travel of the product may be right-to-left or left-to-right, as viewed from behind the print head.

Standby: This option can only be used when the NP 192 type head is chosen. If the head has not printed within the selected number of hours, the system will go into standby mode. Standby mode will lower the head and reservoir temperatures and put the system into idle. To bring the system out of standby, simply start the task.

Double Pulse: Creates a darker print generally needed for the ProSeries 768 and 384.

Enable: Activates the card and errors

Invert: Used for legacy print heads.

Upside down: Used to print the entire image upside down.

More:

Serial params: The port settings for the PHC card. Click **Define...** to change the settings. This is only applicable to PHC_1 and is the Auxiliary Input connection on the Marksman© Pro.

Define: Defines the use and set up of the Auxiliary serial port. Refer to page 27 for additional information.

Linked to: Ties the information to be printed to additional heads. If the information is the same on multiple sides of the box, link the heads together and the image is automatically placed on the other head.

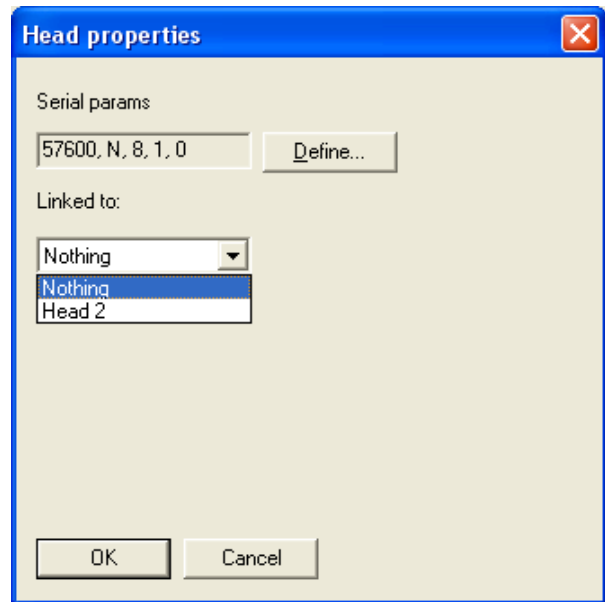

System Barcode Parameters

Refer to *Section 7: BoxWriter Editor, Barcode Parameters.*

System Date/Time Codes

Refer to *Section 7: BoxWriter Editor, Date/Time Codes.*

System Shift Codes

Refer to *Section 7: BoxWriter Editor, Shift Codes.*

General Settings

Used to configure the system COM port.

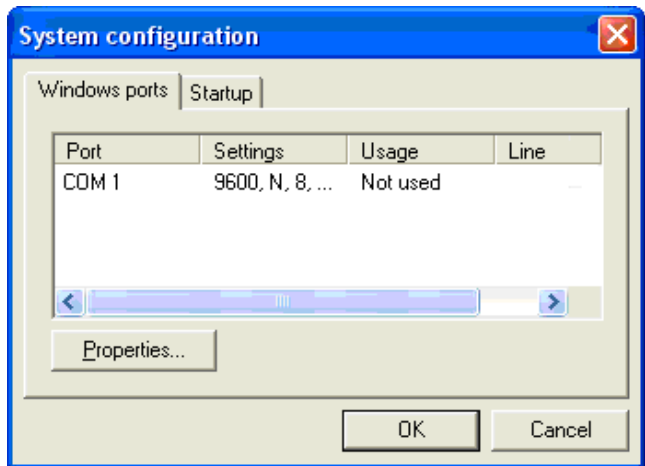

Startup:

To restart the task that was running, if power is lost or the system was shut down, check the "Automatically restart last task" box. (This box is checked by default.)

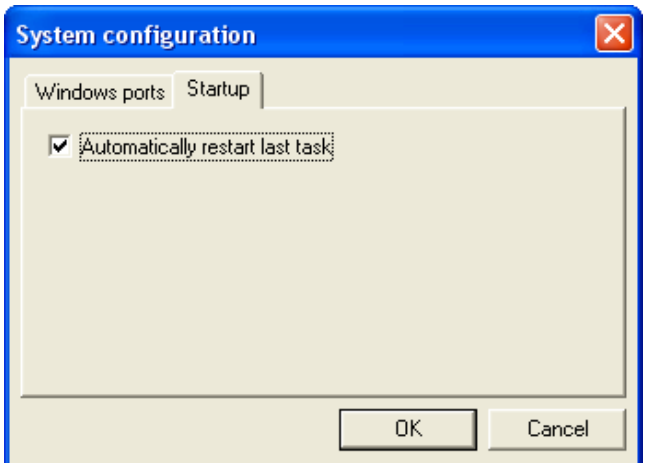

Security

Configure Users

The security feature of the Marksman® Pro Series allows the system administrator to configure users and access rights.

Add: Select the **Add** button to create a user account.

Remove: Select the **Remove** button to delete a user account.

Properties: Select the **Properties** button to modify or view the user account information.

Firstname: Enter the user's first name in this edit box.

Lastname: Enter the user's last name in this edit box.

Username: Enter a unique user account name in this edit box.

Password: Enter a unique alphanumeric user password in this edit box.

ReEnter Password: Enter the same password again for confirmation.

Security Group: Select a security group that provides the access level desired for the user. The user's security group options may be modified or the user may be assigned a different group at a later date.

Click **OK** to save entries and exit the User Info dialog.

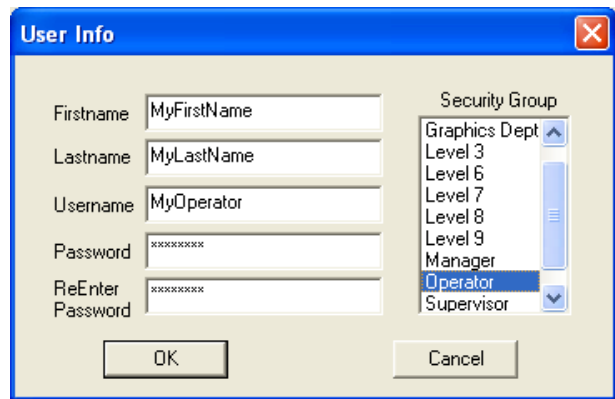
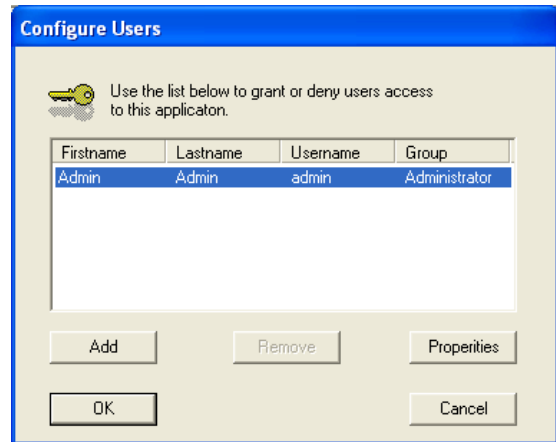

Group Options

Security groups allow the administrator to assign similar users with a specific set of access rights. Select **Security**, then **Group Options** from the menu.

Ten configurable security groups are available. A user must be assigned to one group. Group names may be modified to better describe the access level. Select a Group, then select or unselect Options. Click **Close** to accept changes and close the screen.

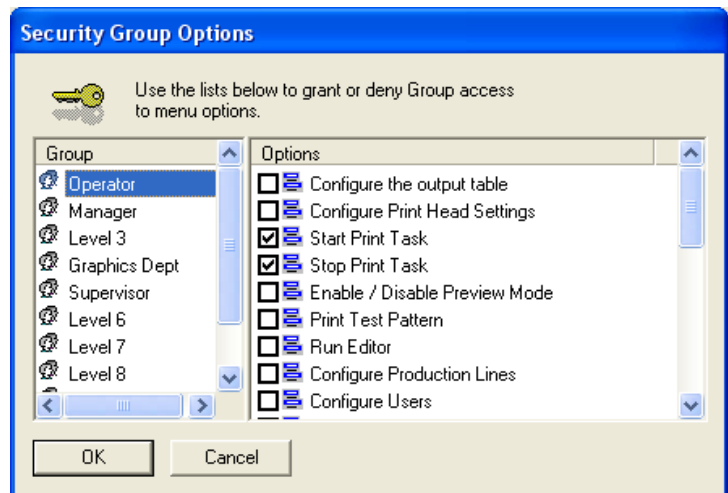

The default access rights for each security group are shown in the following table:

Security Group / Option Access Table	Operator	Manager	Level 3	Graphics	Supervisor	Level 6	Level 7	Level 8	Level 9	Administrator
Configure Print Head Settings		X	X		X	X				X
Start Print Task	X		X							X
Stop Print Task	X		X	X	X					X
Print Test Pattern										X
Run Editor										X
Configure Production Lines			X	X		X				X
Configure Users										X
Configure Group Options										X
System Communications Settings										X
View Printer Report										X
View Scanner Report										X
Configure Date/Time Codes										X
Define Global Barcode Parameters										X
Define the Shift Codes										X
Quit the Application										X
Enable/Disable Preview Mode										X
Refresh Preview										X
Configure Dynamic Data Table										X
Configure General Windows Settings										X
Translate the Software										X
Configure the Output Table										X
Database Start										X
Modify User Element Data										X
Change Count										X
Configure Task Start Database										X

Login



Each user must login to the Marksman© Pro application. The user may log in using the system menu or by selecting the open padlock icon from the tool bar. The shortcut key combination **Ctrl+L** may also be used.

User Name: Enter the user name assigned by the system administrator. The user name is not case sensitive.

Password: Enter the password assigned by the system administrator. The password is not case sensitive.

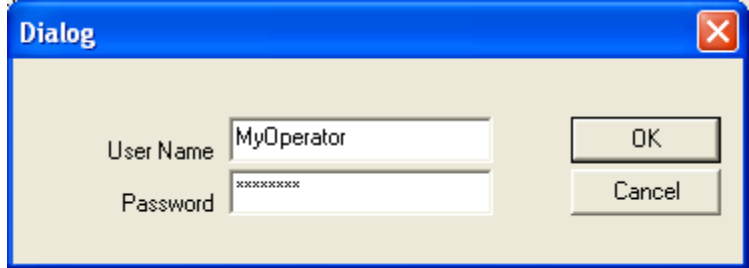

Press the **OK** button to log in.

Logout



Each user should log out of the Marksman© Pro application to enforce the security restrictions. The user may log out using the system menu option **Security > Logout**; or the user may also select the closed padlock icon from the tool bar. The system will continue operating in its current state. All menu options are disabled after the user logs out, with the exception of the Login, About and View Diagnostics items.

Help

Translate

Access **Help, Translate** to select the desired language to be converted to. When the files have been translated, the application will be re-started in the desired language.

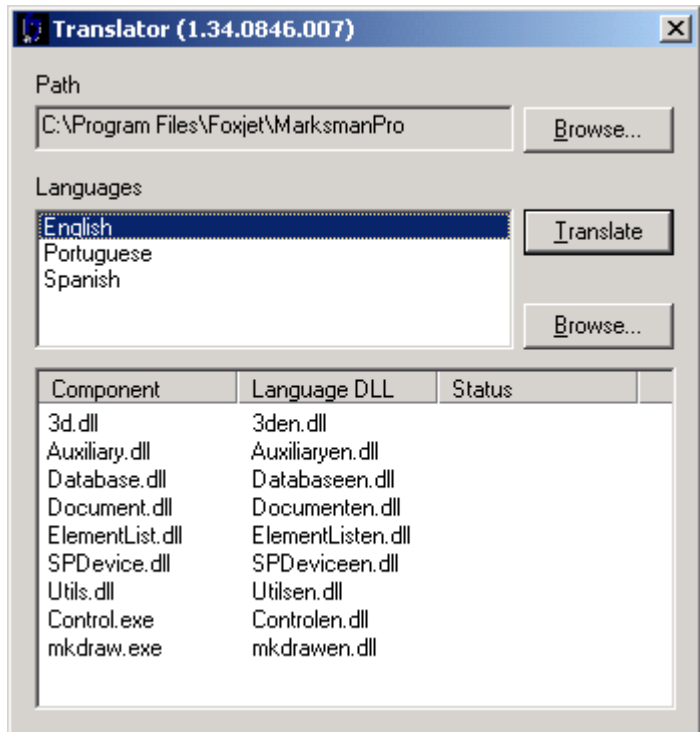

Operation

Operate Start Task

The start task function is used to ready the system to print a label or image that is created with the BoxWriter© Editor.

Select **Operate > Start** from the system menu. Select the desired task from the list, or enter the task name, and press the **OK** button.



The start task icon may be selected from the tool bar, or the shortcut key combination **Ctrl+S** may be used to start a task.

Reset Count to zero: This allows the count value to accumulate if needed or to be reset on every task.

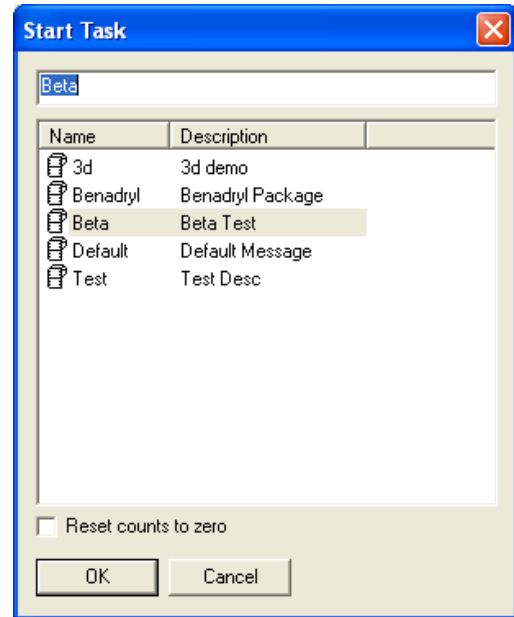

Operate Stop Task

Stopping a task halts all printing related to the selected production line. The product count is reset to zero.

Select the desired production line from the folder tabs; then choose the menu options **Operate, then Stop** to halt printing.



The stop task icon may be selected from the tool bar to stop the task on the selected production line, or the shortcut key combination **Ctrl+End** may be used to stop a task from printing.

Operate Database Start



Set a task based on data that is located in a database. The database must be setup before the icon is available. Refer to *Appendix F: Database Start*.

Operate Idle Task

The Idle task option causes the printing to pause on the selected production line. The product counts are halted until the current task is resumed.

Select the menu options **Operate > Idle** to pause printing.



The Idle Task icon may be selected from the tool bar to invoke the idle function; or the shortcut key combination **Ctrl+I** may be used to idle a running task.

Operate Resume Task

The Resume Task option causes the printing to resume on the selected production line. The product counts are restored from the previously idled task.

Select the menu options **Operate > Resume** to restore printing.



The Resume icon may be selected from the tool bar to initiate the resume function, or the shortcut key combination **Ctrl+R** may be used to resume a task.

Operate Edit

The Edit menu option launches the Marksman® BoxWriter® Editor application. The user must have the required access rights to use this feature.



The Edit icon may be selected from the tool bar, or the shortcut key **Ctrl+E** may be used to launch the Editor.

See the BoxWriter® Editor section of the manual for additional documentation.

Test Pattern



This function is designed to exercise every channel on the print head to verify all are printing properly.

When the user clicks the "Test Pattern" button, a test image is generated. Each head on the currently selected line will print this pattern (along with the print head's name). In the example to the right, the Test Pattern is from Head 1.



Operate Change User Elements

User elements may only be changed if the task is loaded. The task must contain user elements and be "Running" or "Idle" in order to modify user elements.

Select the user element from the list in the dialog. Edit the data in the lower edit box and press **OK** to save changes. For multiple elements, make all data changes before pressing **OK** to save changes. Press **Cancel** to exit without saving changes.

The **F2** function key may be used as the shortcut key to open the user element data dialog.

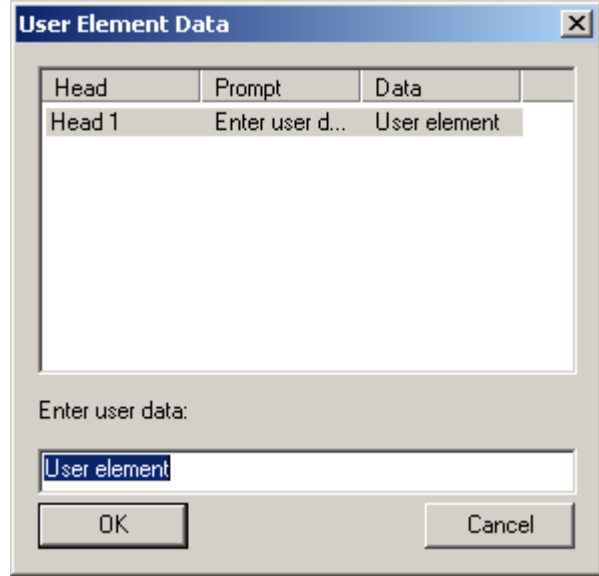

Operate Change Counts

Count is the current number of the box in the pallet series. It is always listed as the "last printed" box. To change the Count value, enter the current box count value. Enter a **0** to print a count of 1 on the next box.

Operate Exit

The user may exit the Marksman© Pro Series control application if the proper security level is assigned. Under normal circumstances there should be no reason to exit the application.

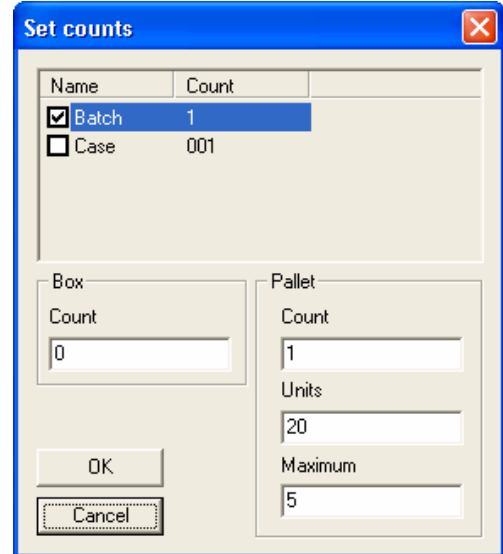

View

View Print Report

The Print Report contains historical information regarding the printing operation. The print report is a table named **reports** within a Microsoft® Access® Database named Marksman-Net. Click on **View**, then select **Printer Report** from the menu.

Time: Time is the date and time that the action occurred.

Action: Action indicates the event such as Start or Stop Task.

User: User is the name of the user who was logged in at the time the action occurred.

Line: Line is the print line that the information is for.

Taskname: Taskname is the name of the task for which the action applies.

Counts: Counts is the product count of the task for which the action applies.

Export: Export allows the information to be saved in a comma delimiter format so it can be used in other software applications.

Auto Export at Task Start: Exports an entry to text file defined by export path.

A sample Print Report is shown below:

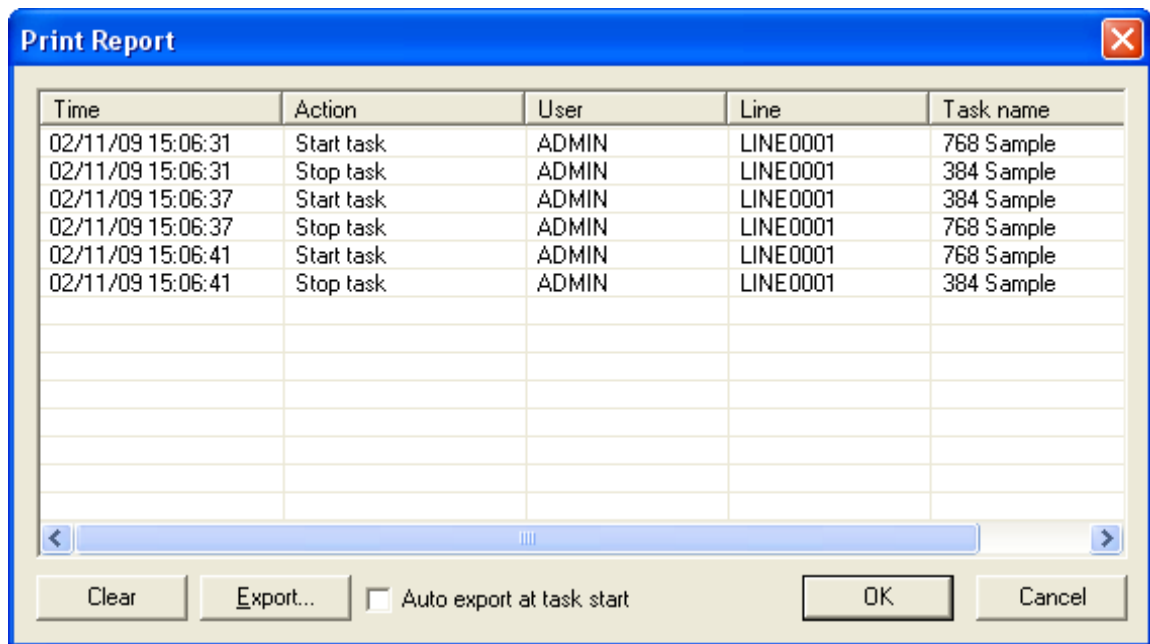

Select **Clear** to remove all items from the report.

View Diagnostic Dialog

The Diagnostic dialog is designed to aid in debugging and verifying the data stream from an externally connected serial device.

The most common use is to verify that a data string is received from a device and that the data is in the desired format.

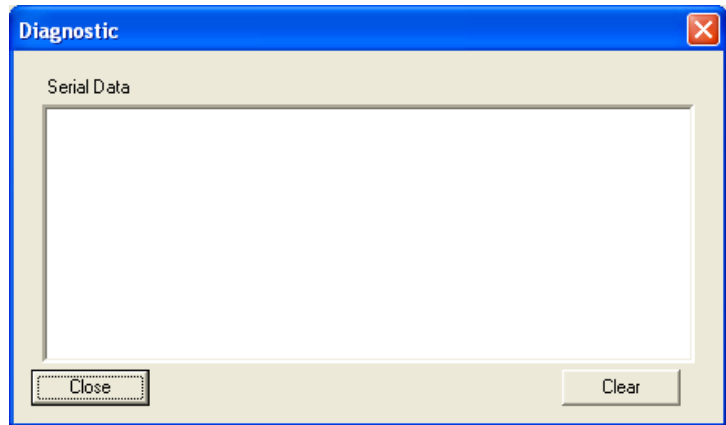

Select **Clear** to remove all items from the dialog.

Preview

This feature may be disabled in certain applications that are switching tasks very quickly.

Refresh

Select a head, then select Refresh to force the preview screen to update all variable fields.

Zoom

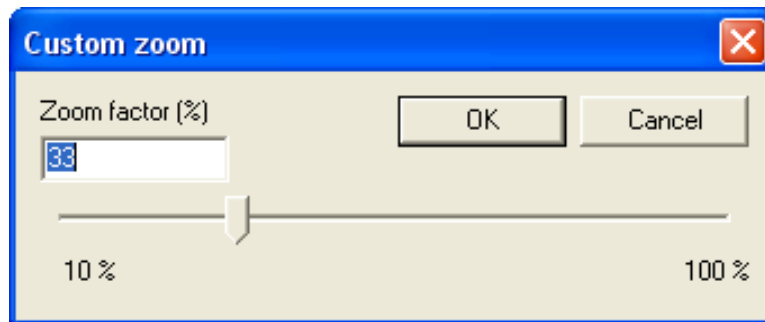

Allows the user to zoom in or out the main preview window.

Section 7: BoxWriter© Pro Editor

Define

Boxes

To define boxes, select **Define > Boxes**.

To add a new box, click **Add**. Enter the length, width, height and name. The length, width and height fields must be between 1 and 40 inches. The description field is optional.

To edit an existing box, select it and click **Edit**, or double-click the item.

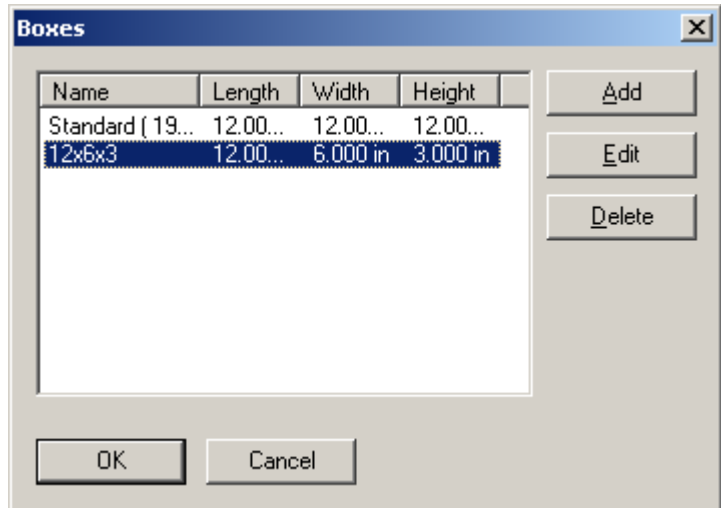

To delete an existing box, select it and click **Delete**. Multiple boxes can be selected by using the shift and/or control keys. Boxes that are currently in use in a task cannot be deleted. The task's box property must be changed before the box can be deleted here.

Pre-printed information can be added to the box to give the operator a true representation of how the box will look as it is being printed on.

Add: Allows the operator to assign a .bmp or .jpg file to a panel on the box.

Edit: Allows the operator to change which .bmp or .jpg file is assigned to a panel of the box.

Delete: Will remove the file from the panel.

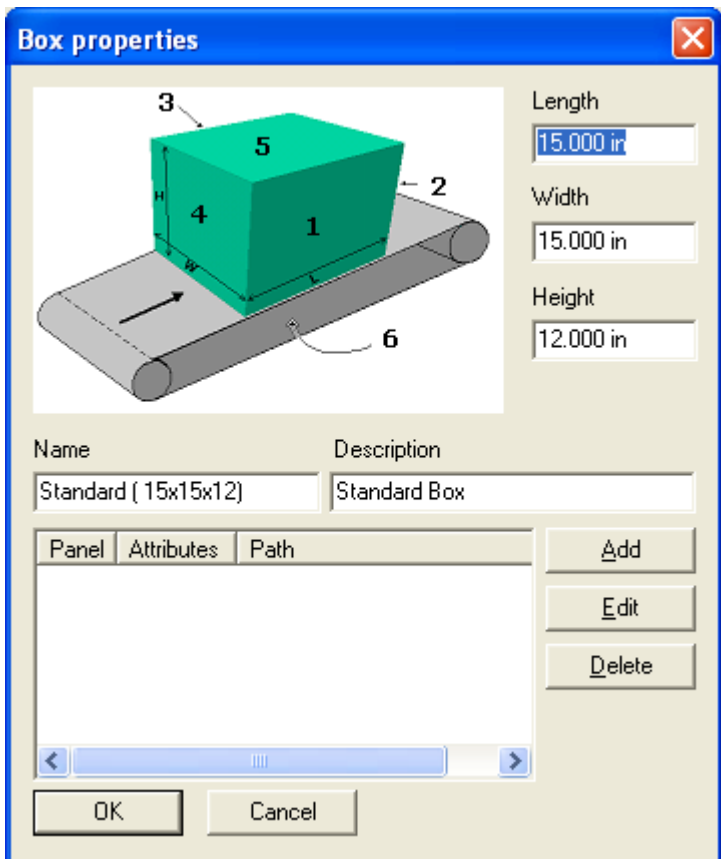

Box Usage

To define box usage, select **Define > Box usage**.

If it is desirable to restrict a box from a given line, it can be done here. By default, all new boxes are available on all lines. To restrict it, select the line, then select the box. It can then be moved to the "restricted" list by clicking the "<" key. Clicking the "<<" moves all boxes for a given line to the restricted list, regardless of selection. Conversely, the ">" and ">>" keys move boxes to the "available" list.

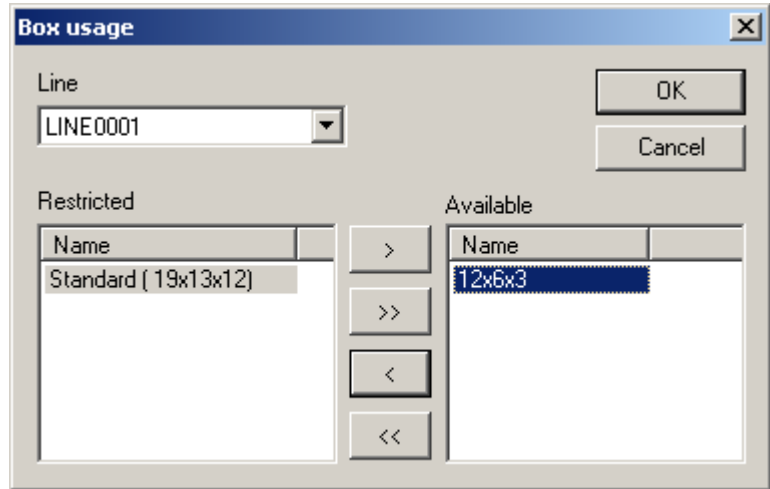

Editor Defaults

To define editor defaults, select **Define > Editor defaults**.

This dialog controls the editor's display units.

The "Resize handle size" field is used by re-sizable elements (such as a Bitmap element). Valid values range from 5 to 15. Larger values make it easier to perform a resize operation on a touch screen.

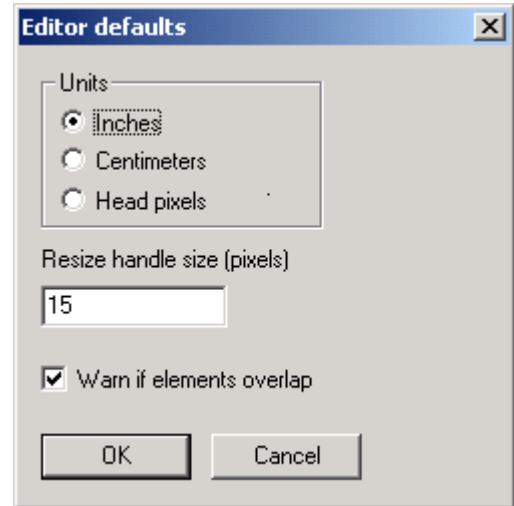

In the example at right, the eight squares around the perimeter are the resize handles.

Checking the "Warn if elements overlap" box will warn the user when element fields overlap in a message.



Element Defaults

To define element defaults, select **Define > Element defaults**. To change the defaults, select an element type and click **Properties**, or double-click the item.

The elements listed here define how new elements are created. (For a description of the individual elements, refer to the *Elements* section of this manual.)

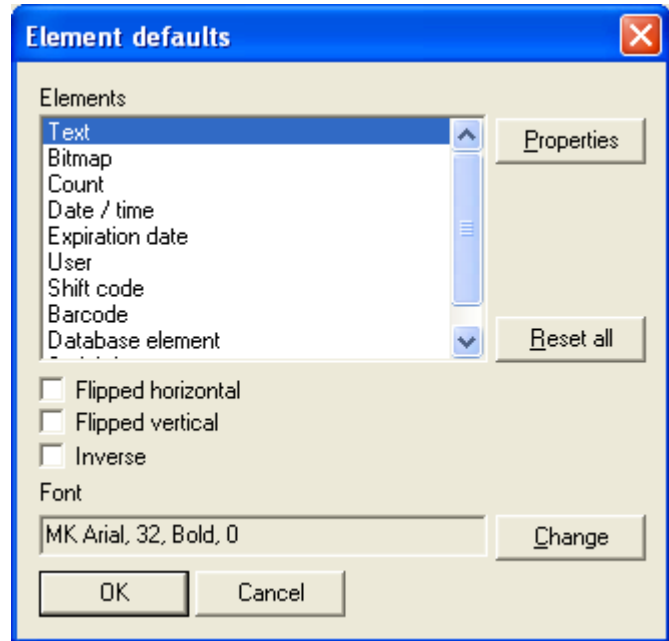

To change the font, click the **Change** button. The dialog at right is used to change the default font parameters.

The Font drop-down box will display a list of all TrueType fonts installed on the system.

The Size field refers to the height of the font in pixels.

Average width defines the average character width (in pixels). A value of 0 means that the system will use the font's default widths.

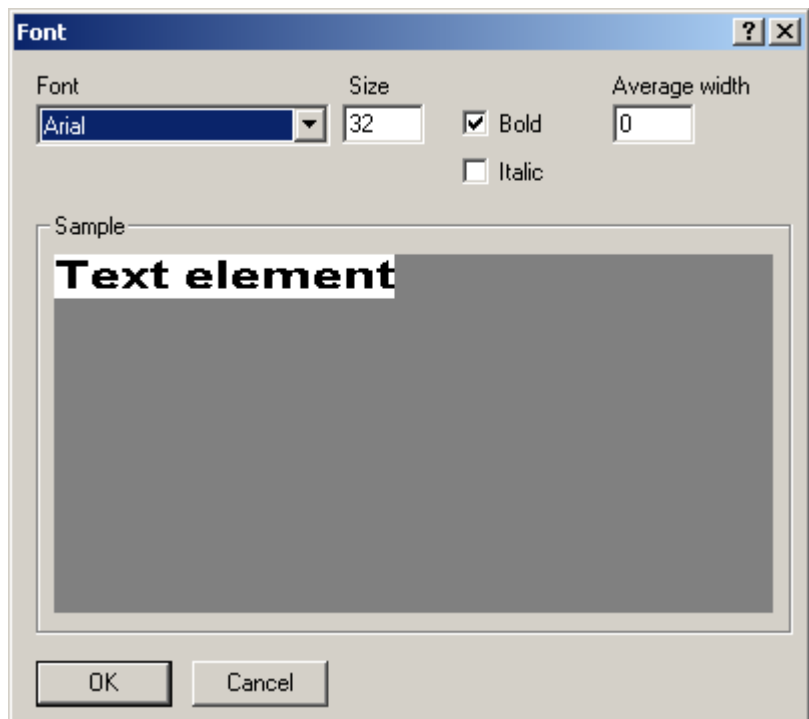

Backup Path

A backup of the Marksman Pro database is stored in a backup location every time the application is closed. The path directs where the file is saved.

Custom Date/Time Formats

To define date/time settings, select **Define > Custom date/time formats**.

The date/time settings shown here are used by Date/time and Expiration date elements.

To create a new custom format, click **Add**.

To delete an existing custom format, select it and click **Delete**. Multiple codes can be selected by using the shift and/or control keys.

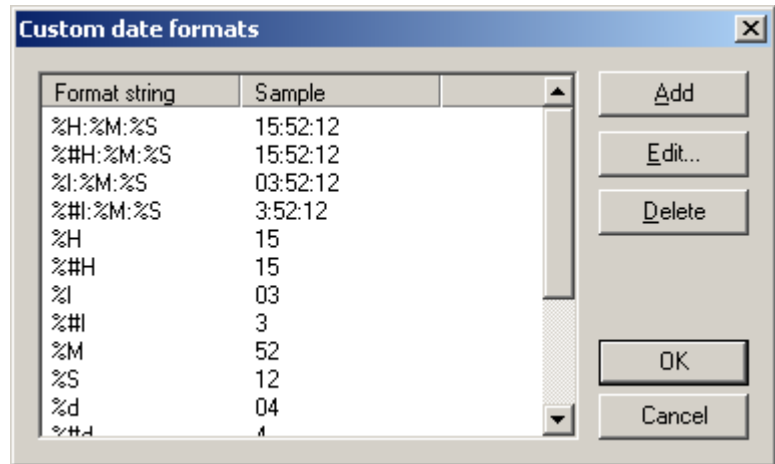

To edit an existing custom code, select it and click **Edit**, or double-click it. The Build date/time format dialog is shown below.

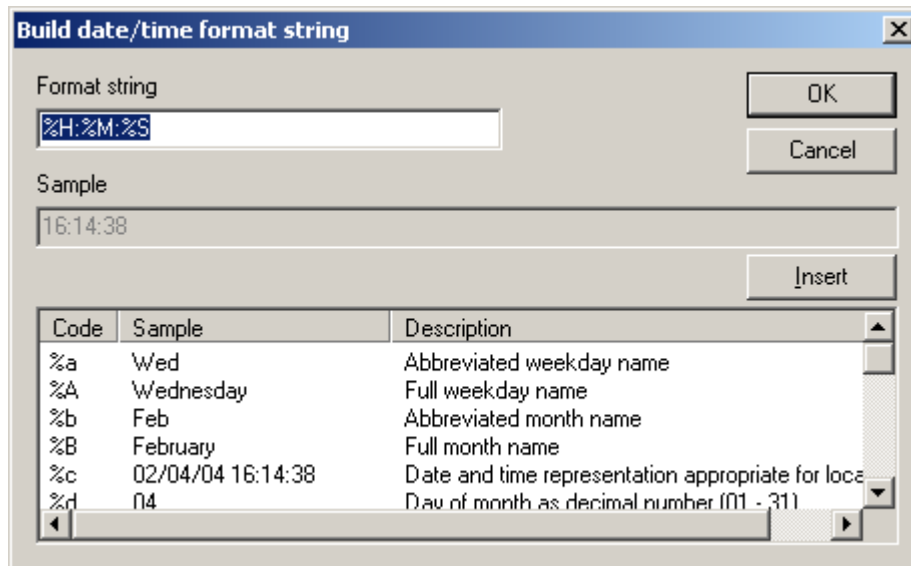

The "Format string" contains a user-defined string consisting of format specifiers.

The "Sample" field shows a sample of the current Format string.

Valid format specifiers are listed at the bottom of the dialog. To insert them in the current string, select them and click **Insert** (or double-click).

Possible format specifiers are listed in the following table:

Specifier	Meaning
%a	Abbreviated weekday name
%A	Full weekday name
%b	Abbreviated month name
%B	Full month name
%c	Date and time representation appropriate for locale
%d	Day of month as decimal number (01 - 31)
%%D	Day of month as decimal number (arbitrary length)
%%-D	Day of month as decimal number, left justified (arbitrary length)
%#d	Day of month as decimal number; no leading zero (1-31)
%H	Hour in 24-hour format, with leading zero (00 - 23)
%#H	Hour in 24-hour format; no leading zero (0-23)
%H:%M:%S	Hour: Minute: Second in 24-hour format, with leading zero on the hour (00-23)
%#H:%M:%S	Hour: Minute: Second in 24-hour format, no leading zero on the hour (0-23)
%l	Hour in 12-hour format (01 - 12)
%#l	Hour in 12-hour format; no leading zero (1-12)
%l:%M:%S	Hour: Minute: Second in 12-hour format; with leading zero on the hour (1-12)
%#l:%M:%S	Hour: Minute: Second in 12-hour format; no leading zero on the hour (1-12)
%j	Day of year as decimal number (001 - 366)
%m	Month as decimal number (01 - 12)
%M	Minute as decimal number (00 - 59)
%%M	Month as decimal number (arbitrary length)
%%-M	Month as decimal number, left justified (arbitrary length)
%p	Current locale's AM/PM indicator for 12-hour clock
%S	Second as decimal number (00 - 59)
%U	Week of year as decimal number, with Sunday as first day of week (00 - 53)
%w	Weekday as decimal number (0 - 6; Sunday is 0)

%W	Week of year as decimal number, with Monday as first day of week (00 - 53)
%x	Date representation for current locale
%X	Time representation for current locale
%y	Year without century, as decimal number (00 - 99)
%Y	Year with century, as decimal number
%%Y	Year as decimal number (arbitrary length) <u>Examples:</u> "%%YYYY" is formatted as "2004" "%%YY" is formatted as "04" "%%Y" is formatted as "4"
%%-Y	Year as decimal number, left justified (arbitrary length)
%z; %Z	Time zone name or abbreviation; no characters if time zone is unknown
%%	Percent sign
%%0H	Hour Code
%%0M	Month Code
%%0A	Day Code
%%0Q	Quarter Hour Code
NOTE: The # flag may prefix any format specifier. In that case the meaning of the format code is changed as follows:	
##a, ##A, ##b, ##B, ##p, ##X, ##z, ##Z, ##%	# flag is ignored
##c	Long date and time representation, appropriate for current locale. For example: "Tuesday, March 14, 1995, 12:41:29"
##x	Long date representation, appropriate to current locale. For example: "Tuesday, March 14, 1995"
##d, ##H, ##l, ##j, ##m, ##M, ##S, ##U, ##w, ##W, ##y, ##Y	Remove leading zeroes (if any)

Date/Time Codes

Select **Configure, System**, then **Date/Time Codes** from the menu.

Line: Line indicates the production line selected.

Click on the folder tabs to access the date/time code tables. Select an entry in the table by clicking on the desired row. Click on **Edit** to modify the data for the selected table entry.

Click **OK** to exit and save changes or **Cancel** to exit without saving changes.

Months: Months represents the string values that are used in date codes for the standard months of the year.

Hours: The Hours table stores the twenty-four codes for the hours of the day. The codes may be customized for special coding.

Quarter Hours: The Quarter Hours' table stores codes for 15 minute intervals.

Days: The day table holds the value to be used for the appropriate day.

Rollover: The time at which the expiration and date codes will change to a new value. The default rollover value is midnight.

"Hold": Holds the Date or Expiration Date until the Roll over time.

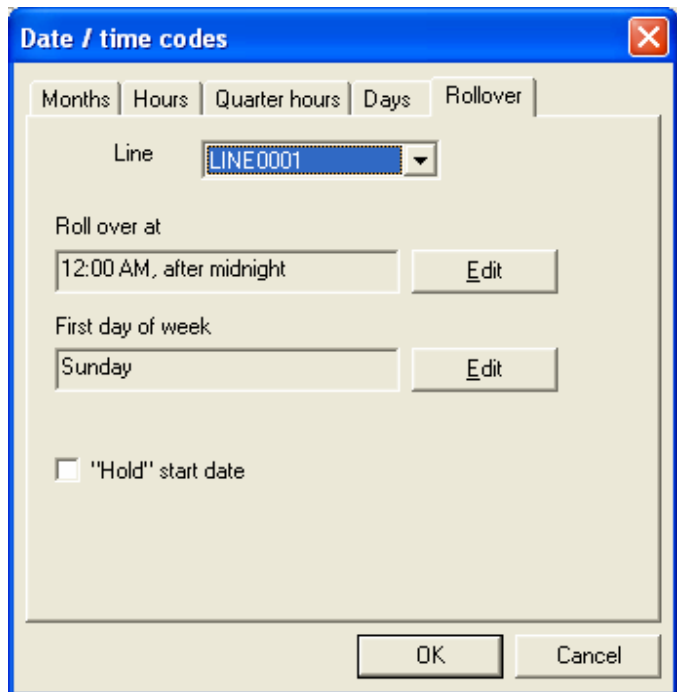
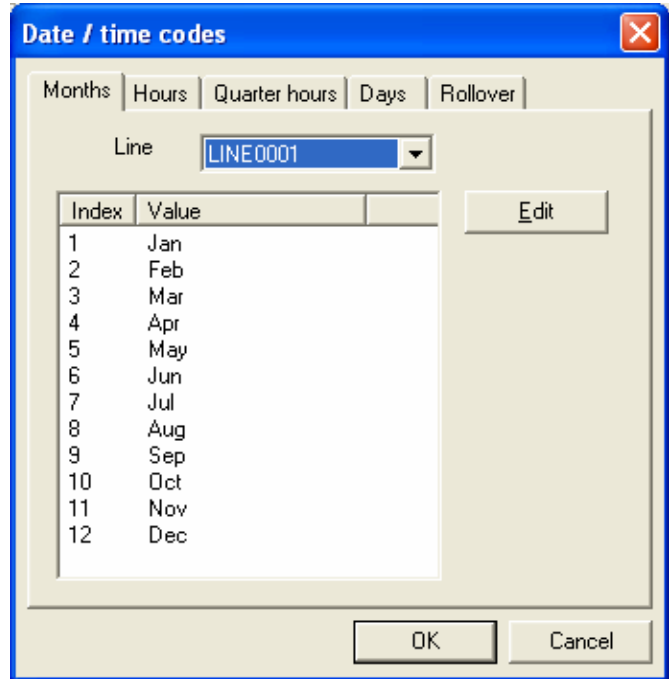

Bitmap Editor

To define bitmap settings, select **Define > Bitmap settings**.

The "Bitmap editor" field defines the program used to edit bitmaps. By default, it is Microsoft® Paint. To change it, browse and select the program to be used.

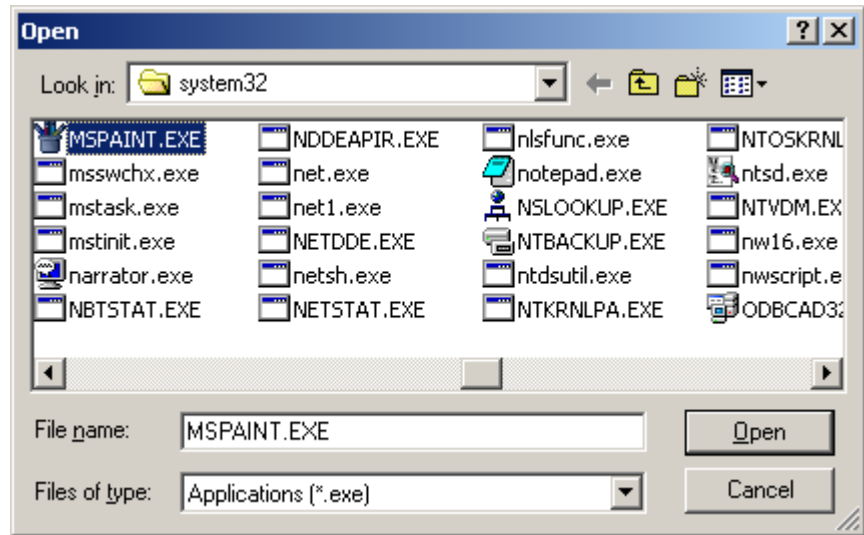

Label Editor

Used to configure software when Marksman Pro is used with a Label Applicator.

Shift Codes

To define shift codes, select **Define > Shift codes**. Shift codes are used by Shift elements.

The shift code's length must be from 1 to 15 characters. The code's times must be in order from least to greatest (i.e., code 1 cannot be later than code 2 or 3).

Line: This determines the production line for the shift code definitions.

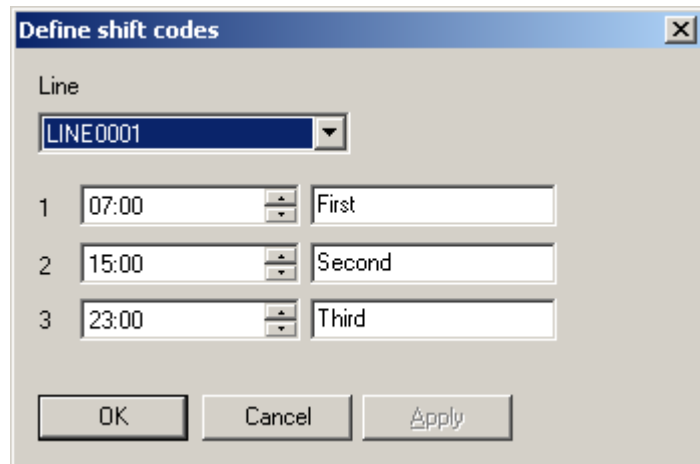

Select the appropriate production line. Enter the shift start times and any user-defined codes. The shift start times must be entered in 24-hour format. The shift code may contain a maximum of 15 alphanumeric characters.

The sample dialog shows shift 1 starting at 7:00 AM, shift 2 starting at 3:00 PM and shift 3 starting at 11:00 PM.

Sub-Elements

To define fonts, select **Define > Sub-elements**.

Sub-elements can be used by certain barcodes (see the *Barcode* section of the manual for usage). The Sub-elements dialog is shown below.

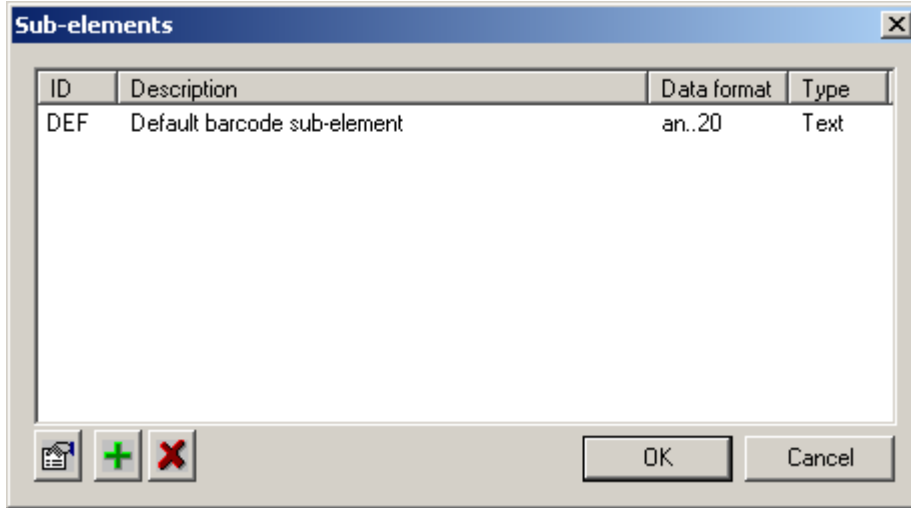

To create a new sub-element, click the "+" button.

To delete an existing sub-element, select it and click the "X" button.

To edit an existing sub-element, select it and click the **Properties** button (the bottom, left-most button). The Sub-element properties dialog is shown below.

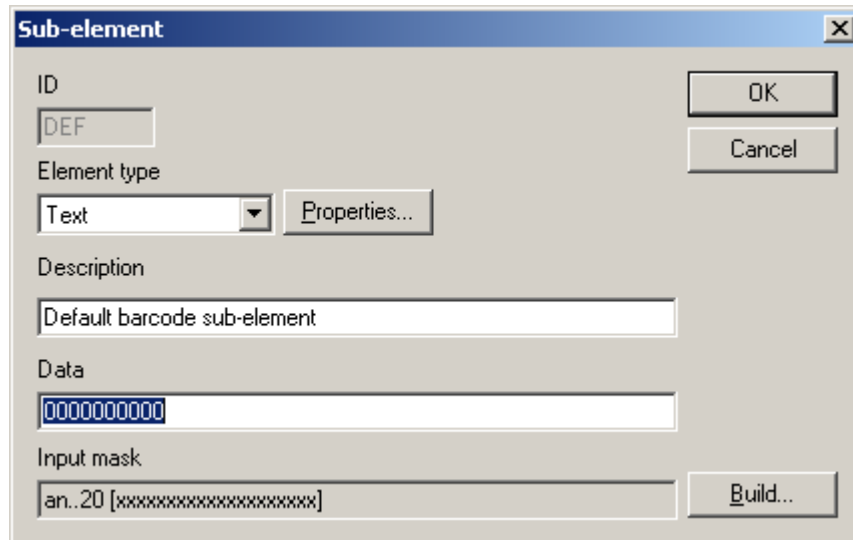

The "ID" field identifies the sub-element.

The "Element type" field defines the type of element. The following types are supported by sub-elements:

- Text
- Count
- Date / time
- Expiration date
- Shift
- User
- Serial data

To change the element's default values, click the **Properties** button. See the *Elements* section of the manual for examples of property dialogs for element types.

The "Description" field is used for a long-hand description of the sub-element.

The "Data" field contains the default data for the sub-element. Note that the Data must satisfy the Input mask.

The Input mask defines what kind of data the sub-element can accept. To change it, click the **Build** button. The Build mask dialog is shown at right.

In this example, the mask is set up for data consisting of two digits and up to 10 alpha-numeric characters.

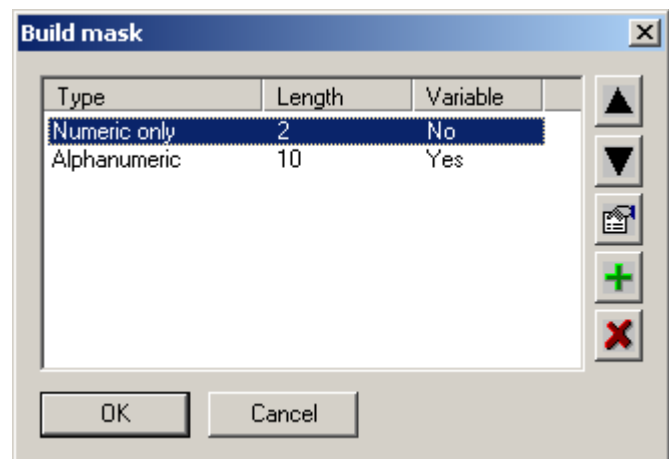

The buttons along the right side of the dialog are as follows, from top to bottom:

- Move up - moves the selected mask up.
- Move down - moves the selected mask down.
- Properties - displays the mask properties for editing.
- Add - creates a new mask.
- Delete - deletes the selected mask.

The following is an example of the Mask properties dialog:

- Alpha allows uppercase A to Z.
- Numeric allows 0 to 9.
- Alphanumeric allows uppercase A to Z or 0 to 9.
- Punctuation allows characters such as "," or ":".
- Any allows any character.

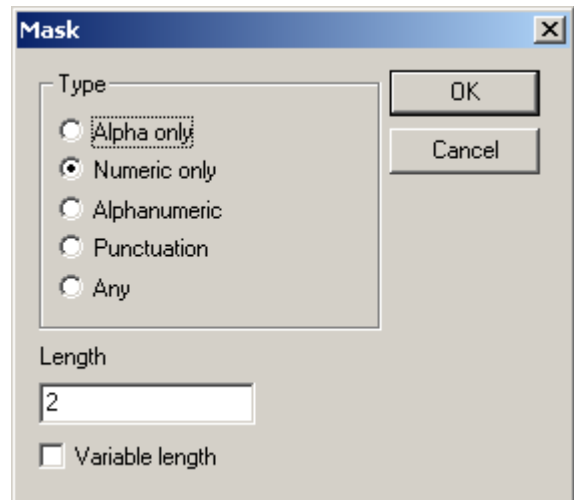

Application Identifiers

To define fonts, select **Define > Application identifiers**.

Application identifiers can also be used by certain barcodes. They work in the same manner as sub-elements.

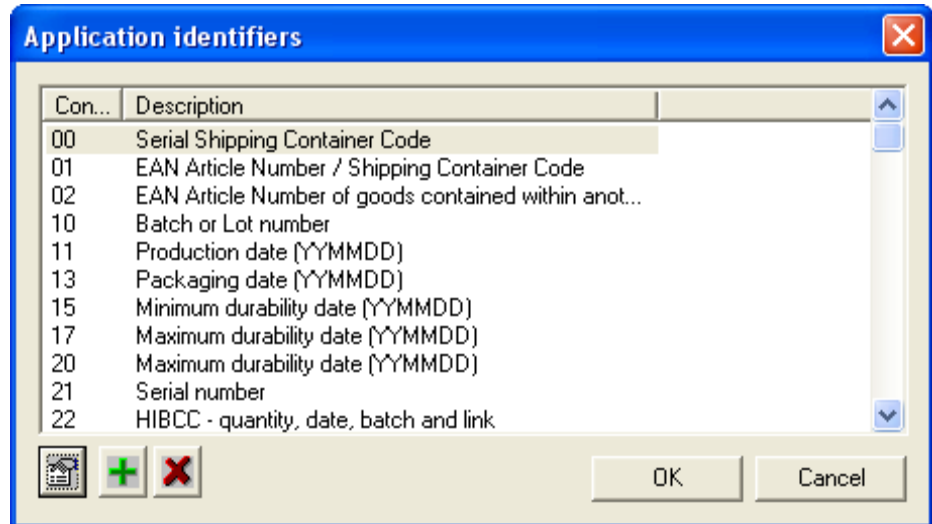

An example of the Application identifier properties dialog is shown at right.

Only the "Element type" and "Data" fields can be changed. See the *Sub-elements* section for descriptions of these fields.

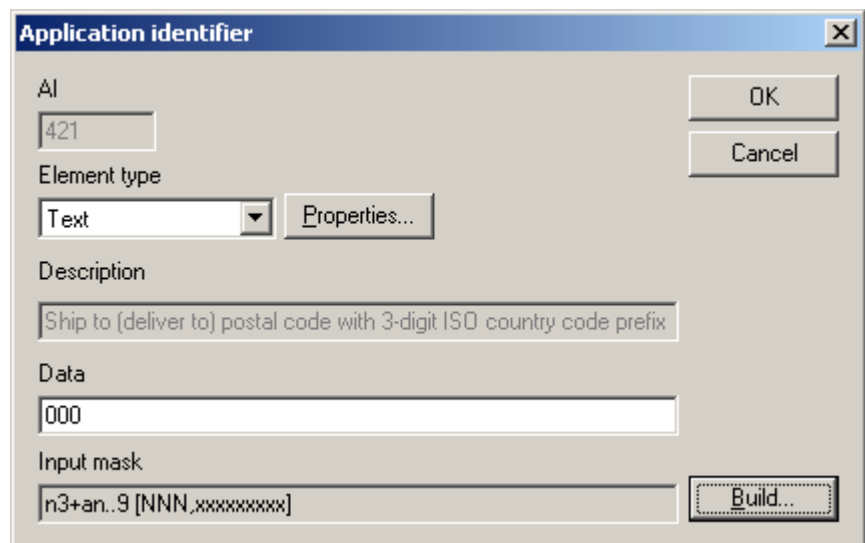

Global Barcode Parameters

To define barcode parameters, select **Define > Global Barcode Parameters**.

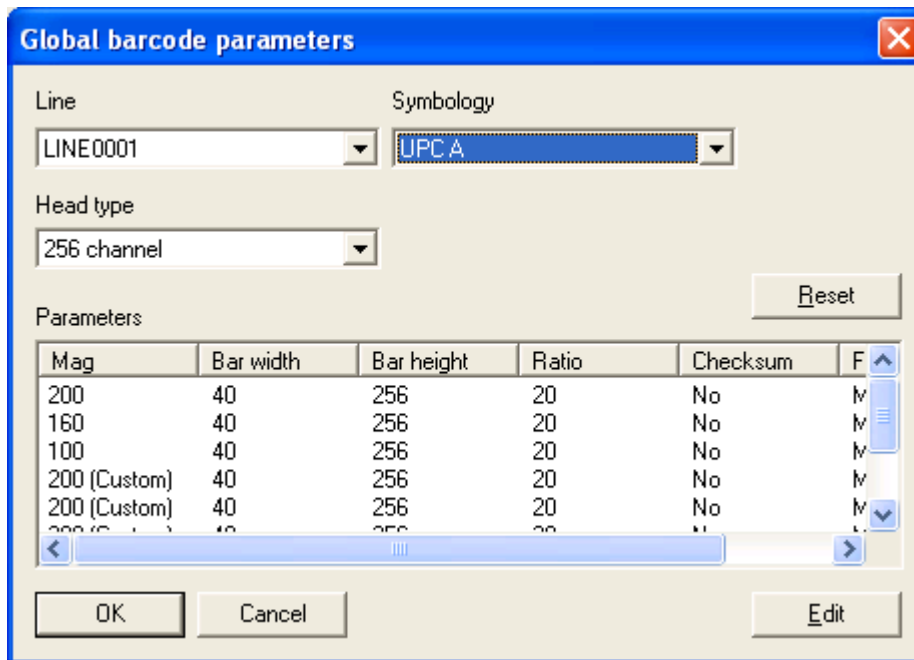

Select the line, then select the head type. Heads with 32 channels have their own set of barcode parameters, as do 256 channel heads.

To view or edit a set of barcode parameters, select it then click **Edit**, or double-click the item.



NOTES:

Only the custom bar and space parameters can be changed; and only a person having advanced knowledge of barcode and inkjet printing systems should change these parameters. An unusable barcode may be printed using improper settings.

C128, C39, C93 & I 2of5: On standard barcode parameters, the Magnification, Width, Total height and Ratio cannot be changed. Only custom parameters allow these fields to be changed.

UPC: On standard barcode parameters, the Magnification, Bar width and Space width cannot be changed. Only custom parameters allow these fields to be changed.

An example of UPCA barcode parameters is shown at right.

The "Magnification" field is the value displayed in the Magnification field on the Barcode element dialog.

The "Bar height" is the total height of the symbol in pixels.

The "Bar width" and "Space width" fields define the width, in pixels, of the symbol's bar/space modules.

The "Font name" control will display a list of all TrueType fonts installed on the system.

The "Font size" field refers to the height of the font in pixels.

"Average width" defines the average character width (in pixels). A value of 0 means that Windows will use the font's default widths.

The "Magnification" field is the value displayed in the Magnification field on the Barcode element dialog.

The "Total height" is the total height of the symbol in pixels.

The "Horz. bearer" field specifies the width of the symbol's horizontal bearer, in thousandths of an inch.

The "Vert. bearer" field specifies the width of the symbol's vertical bearer, in thousandths of an inch.

The "Quiet zone" field specifies the width of the symbol's quiet zone, in thousandths of an inch.

The "Font name" control will display a list of all TrueType fonts installed on the system.

The "Font" size field refers to the height of the font in pixels.

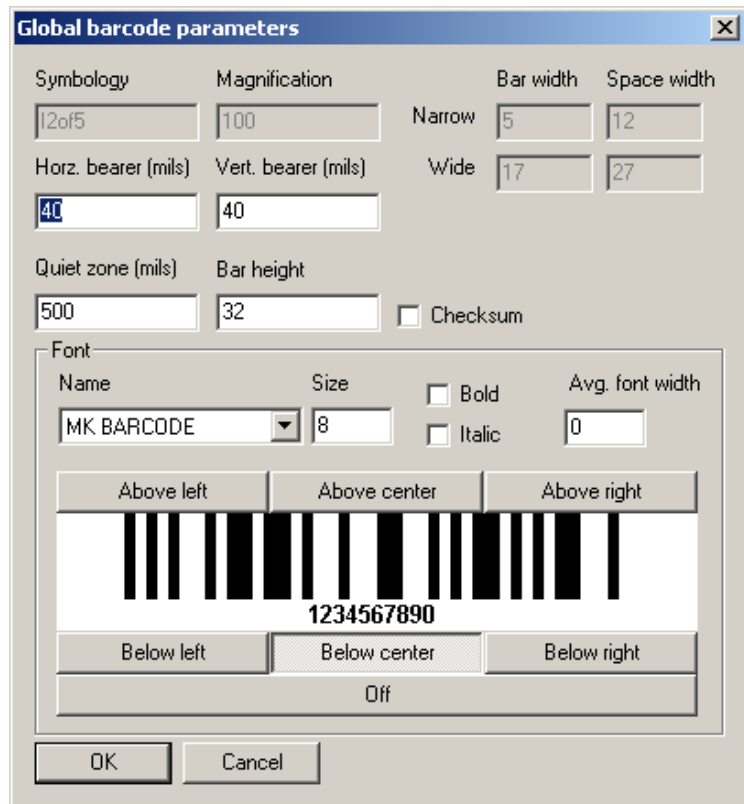
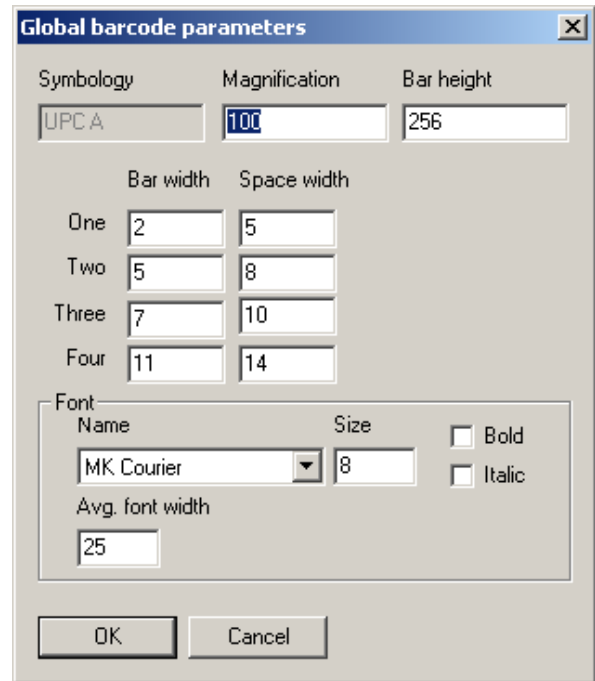

Tools

Ink Usage

The ink usage generator will calculate the cost of each print and how many prints you will get from each bottle.

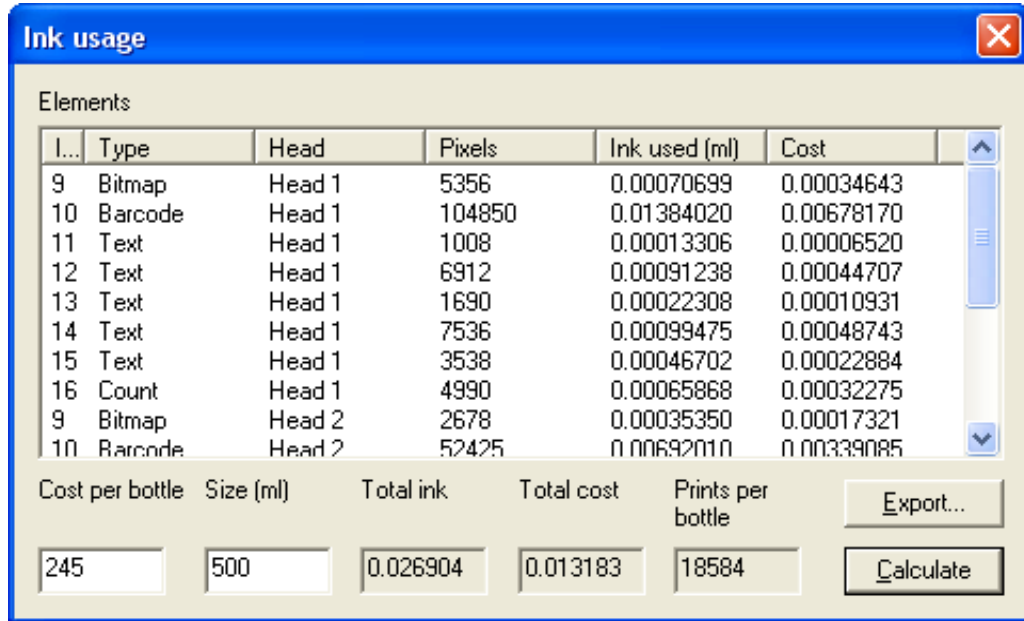

Files

New

To create a new task, choose **File > New**.

The user will be presented with the dialog at right. Pick which production line the task is to be created for, give it a name (and description, if desired) and select the box it will be printed on.

The "Task name" field must contain only letters and numbers; no spaces or special characters are allowed. The maximum number of characters is 32.

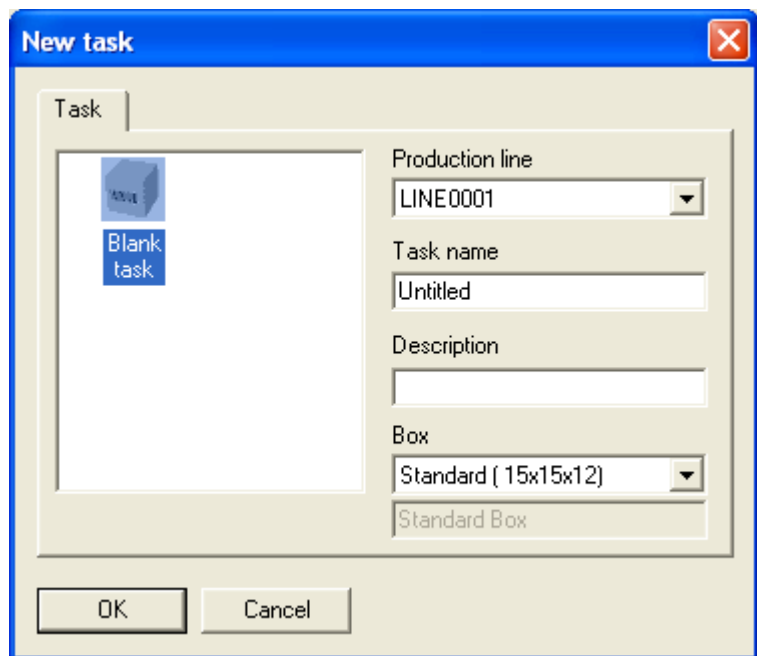

Creating a Task

The next step is to insert elements into the label to be printed. The box is shown with highlighted areas showing where heads have been placed on the box. The printing areas cannot be changed from the editor because the information about the heads and their relationship to the box comes from the system configuration, which is limited by physical devices installed. Different panels can be selected to add elements to the task. Once a head has been chosen, select an element to be placed on the box. The process is repeated until all the desired information needed on all sides of the box are completed. The next step would be to save the task. (Refer to appropriate sections in this manual relating to Elements and Saving Files.)

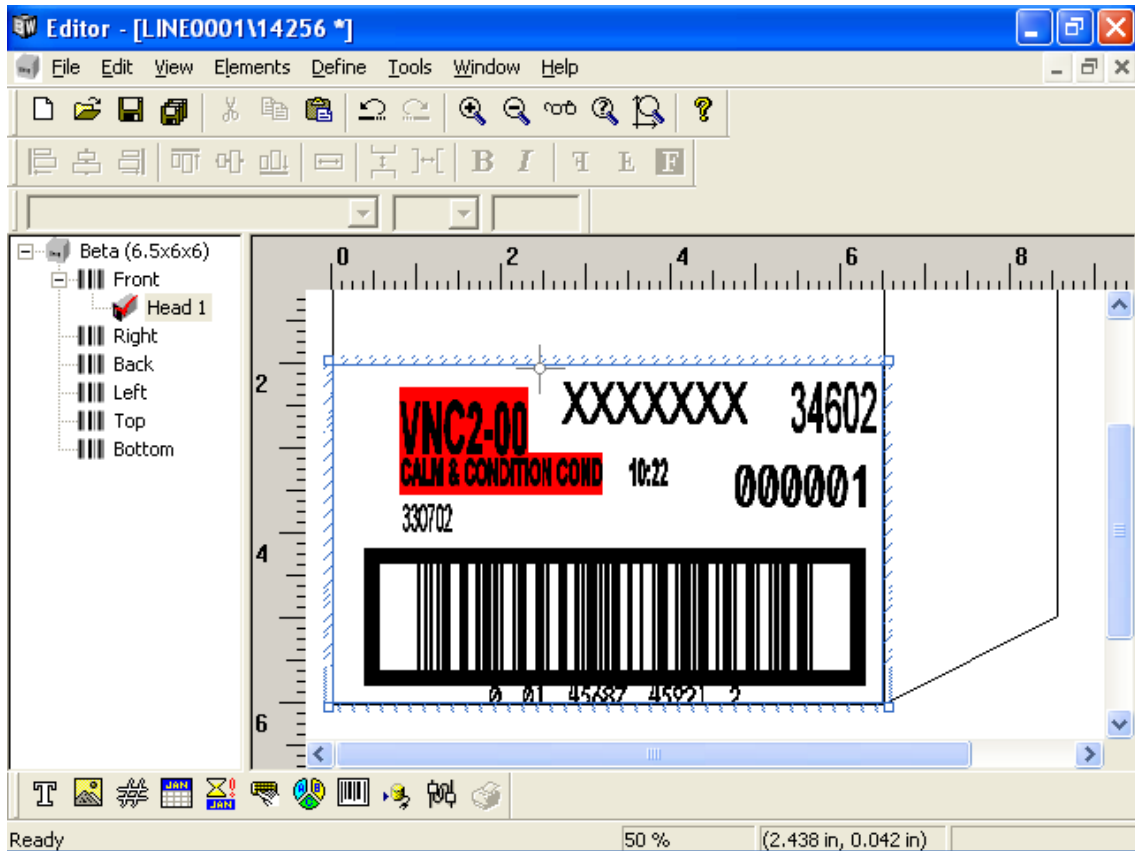

NOTE: If two elements overlap each other they both will show up in red. This is to let the operator know that a problem may occur. The operator will also be told before saving the task.

To disable the element overlap warnings, see *Define, Editor Defaults* earlier in this section.

Open

To open an existing task, choose **File > Open**.

Select the task to be opened, and click **OK**; or double-click the task to be opened.

Checking the "Open read only" box will open the task in read-only mode (i.e., the user will not be able to modify the task).

Checking the "Show preview" box will show a preview of the selected task. For large tasks, it may take several seconds to generate the preview.

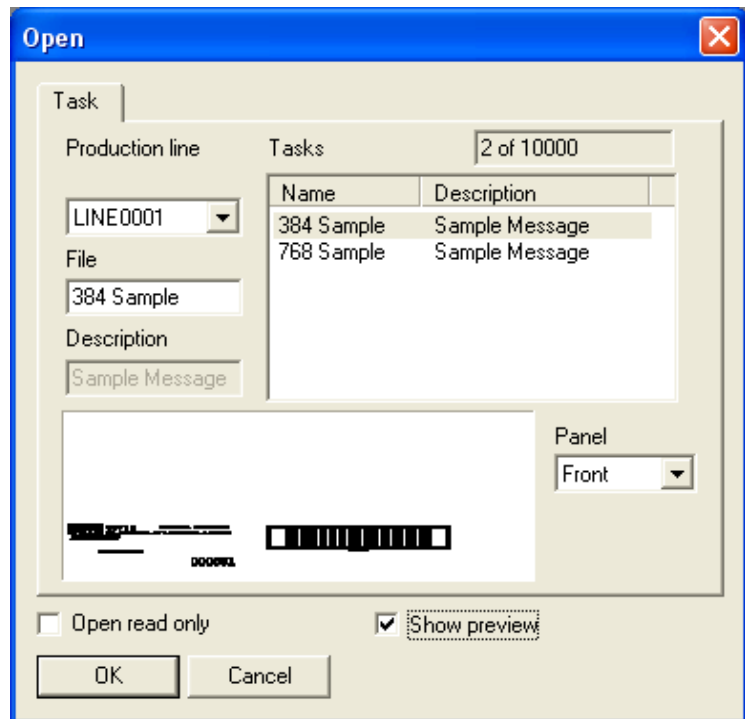

Copy

To copy tasks from one line to another, choose **File > Copy**.

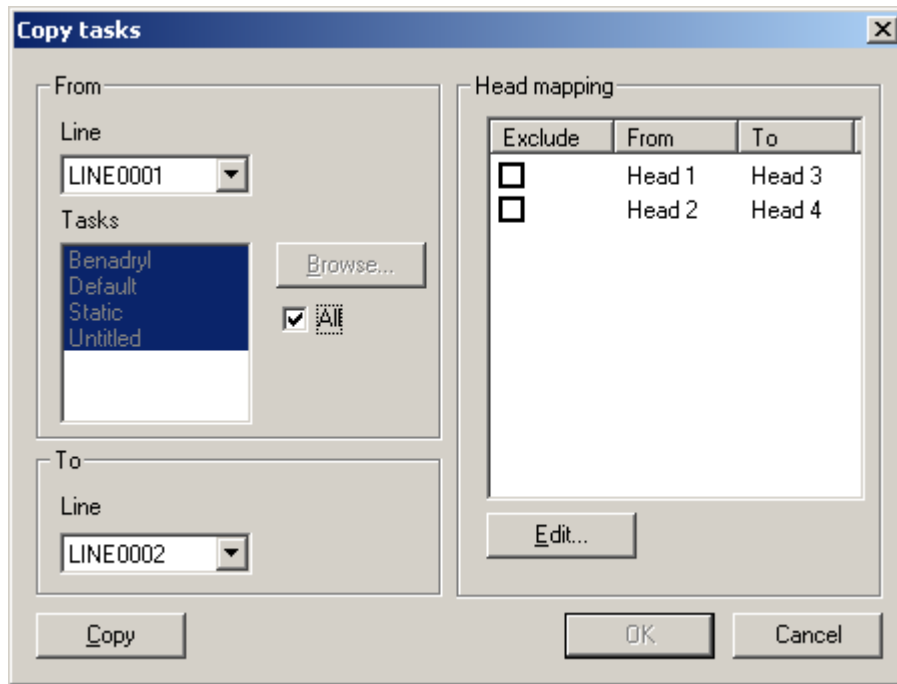

Select the line to copy from, then select the tasks to be copied. Checking the "All" box will automatically select all existing tasks for the given line.

When the desired tasks are selected, click **Copy**.

If successful, you will see a confirmation message similar to the one at right.

The user may change both the "To" and "From" lines and perform the copy function multiple times.

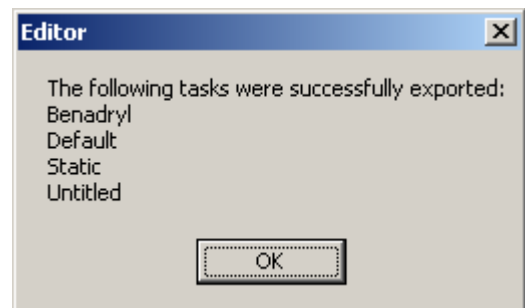

Click **OK** after to save the changes.

This function works best when both the "To" and "From" lines have identical head configurations. However, if they do not, the user may elect to configure the head mapping. To do this, select the head to be mapped and click **Edit** (or double-click).

The user will be presented with the dialog at right. Select the head to map to in the "To" field and click **OK**.

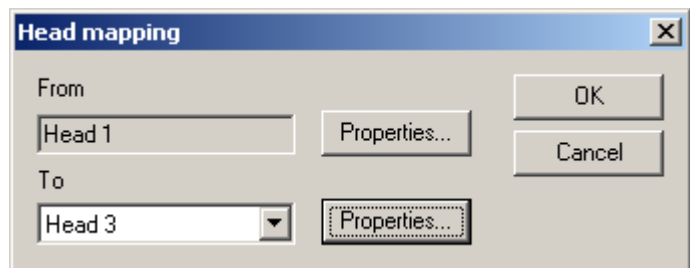

Clicking **Properties** will bring up the Head properties dialog. Note that head properties are read-only in the Editor.

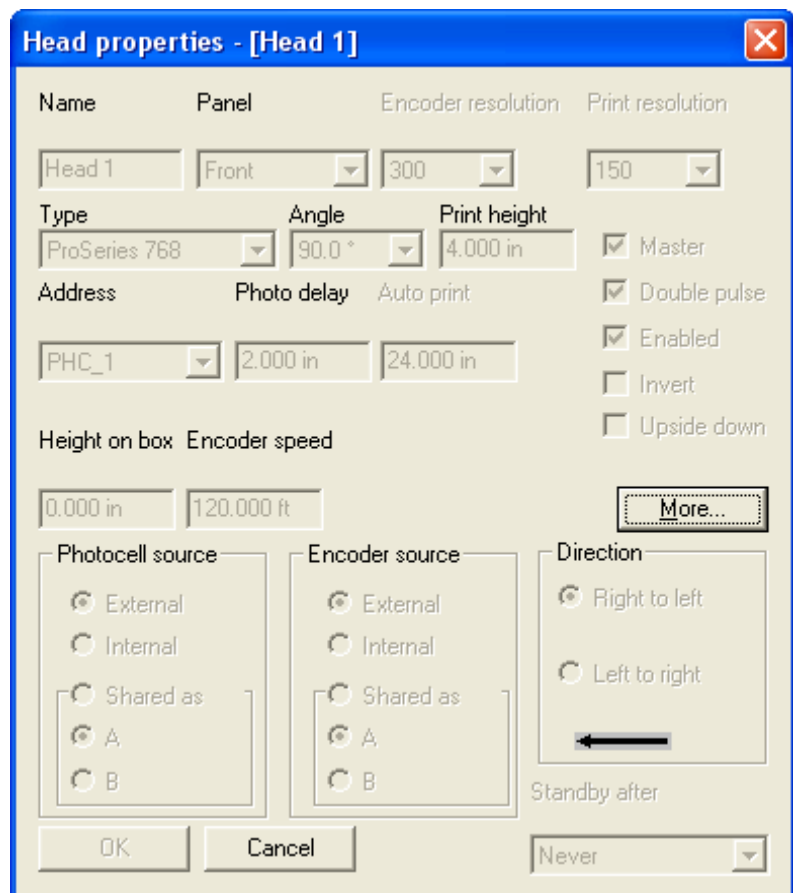

Import



NOTE: It is recommended that all printing tasks be stopped until the Import function has been successfully completed; and that the current database be exported for backup purposes.

To import all tasks that were previously exported, choose **File**, then **Import**.

In the "filename" field, input the name of the file (full path) the exported tasks were saved to; or browse for the file by clicking the **Browse** button.

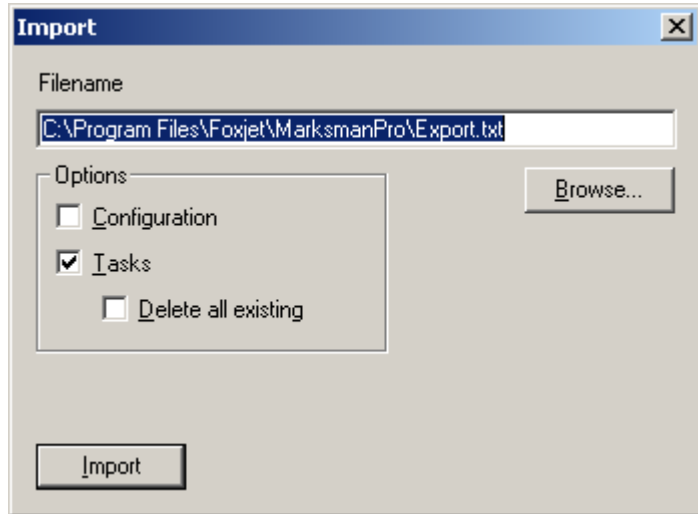

If there is data on the controller that the user does not want to lose, click **Yes** on the following screen.



The screen at right will appear at the completion of the Import function.

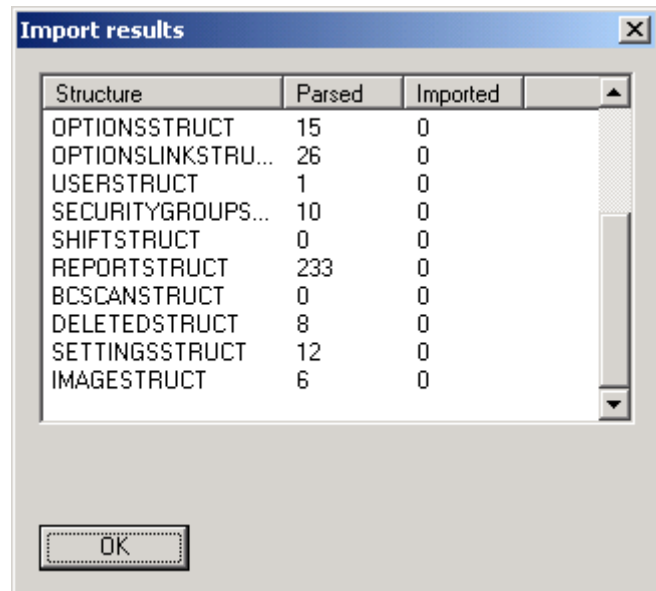

Export



NOTE: It is recommended that all printing tasks be stopped until the Export function has been successfully completed.

To export all existing tasks, choose **File**, then **Export**.

Input the name of the file to export to, or browse for an existing file by clicking the **Browse** button. Click the **Export** button. If the file already exists, the user will be prompted to overwrite the file or cancel the request.

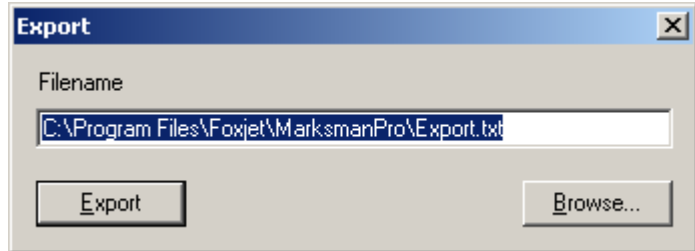

If successful, a confirmation message will appear.

Delete

To delete existing tasks, choose **File > Delete**.

Select the task to be deleted. Multiple tasks may be selected by using the control and/or shift keys. When the selection has been made, click **Delete**.

The delete function may be used several times without closing the window. Tasks on other lines may also be deleted.

Click **OK** to save the changes.

Checking the "Show preview" box will show a preview of the selected task. For large tasks, it may take several seconds to generate the preview.

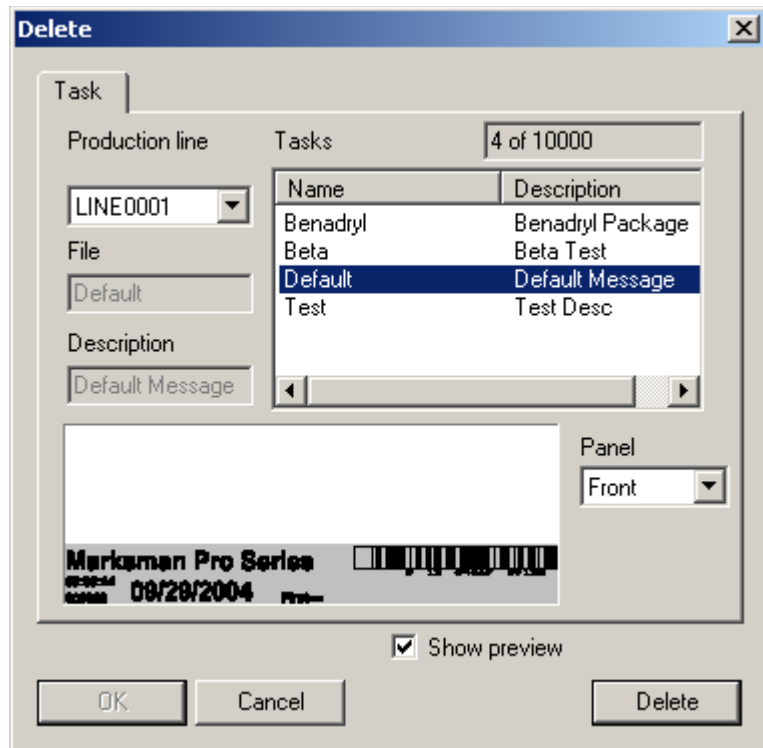

Save As

To save an open task under a different name, choose **File > Save as**.

The "File" field must contain only letters and numbers; no spaces or special characters are allowed. The maximum number of characters is 32.

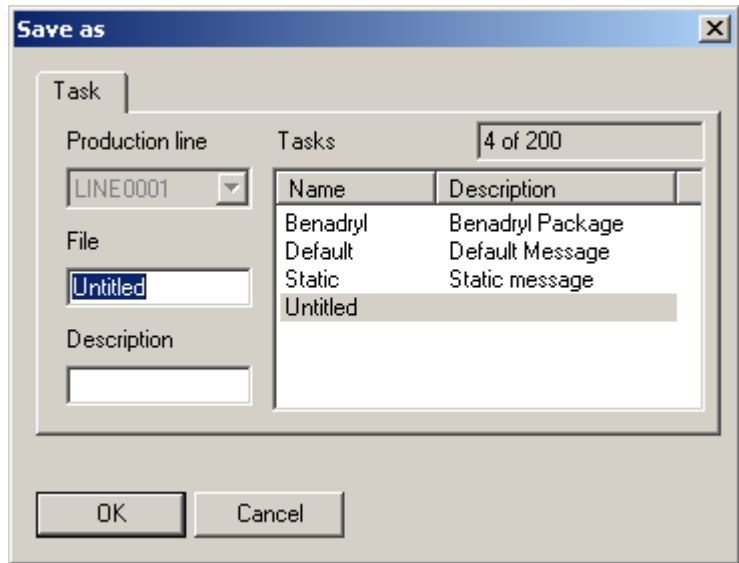

If the name entered matches a task already in the database, the user will be prompted with a confirmation dialog, like the one at right.

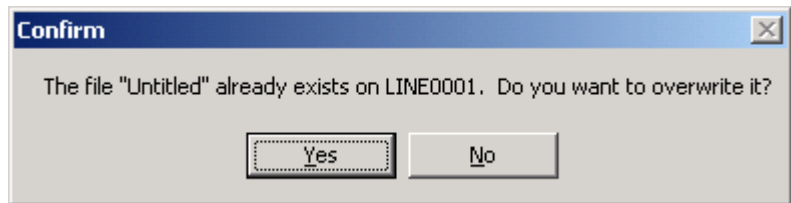

Properties

To change an open task's properties, choose **File > Properties**. The task's description, download string, box and/or expiration data may be changed using this dialog.

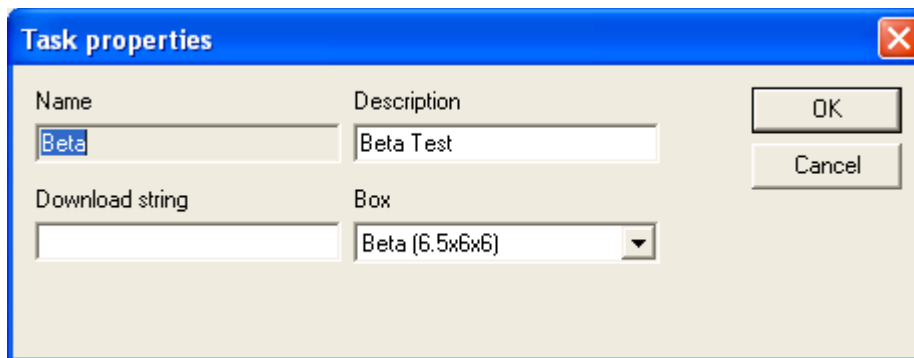

The following table lists special ASCII characters that can be entered in the "Download String" field. (For example, to send 0012345 terminated by a carriage return, enter "0012345<CR>" in the Download String.)

Character	Description
<NULL>	Null
<SOH>	Start of heading
<STX>	Start of text
<ETX>	End of text
<EOT>	End of transmission
<ENQ>	Enquiry
<ACK>	Acknowledge
<BEL>	Bell
<BS>	Backspace
<HT>	Horizontal tab
<LF>	NL Line feed, New line
<VT>	Vertical tab
<FF>	NP Form feed, New page
<CR>	Carriage return
<SO>	Shift out
<SI>	Shift in
<SLE>	
<DC1>	Device control 1
<DC2>	Device control 2
<DC3>	Device control 3
<DC4>	Device control 4
<NAK>	Negative acknowledge
<SYN>	Synchronous idle
<ETB>	End of transmission block
<CAN>	Cancel
	End of medium
<SIB>	Substitute
<ESC>	Escape
<FS>	File separator
<GS>	Group separator
<RS>	Record separator
<US>	Unit separator

Exit

To exit the Editor, choose **File > Exit**.

Elements

Element Bar



Using the element bar, the user can add new elements to a task. Element types, from left to right, are as follows:

- Text
- Bitmap
- Count
- Date / time
- Expiration date
- User
- Shift
- Barcode
- Database
- Serial

New elements can be created by clicking one of the buttons on the element bar, by right-clicking on the printable area of the box, or by using the **Elements > Add** menu.

When creating a new element, its x, y position (top-left corner) is set to the current location of the crosshairs.

To edit an existing element's properties, select the element by clicking it, then choose **Elements > Edit** from the menu (or press **Enter**); or double-click an element to edit its properties. Only one element at a time can be selected to edit.

Text

The Text element properties are shown on the right. Text can be entered into the field either a single line at a time or multiple lines, paragraph mode. To get to the next line, simply press Control and Enter at the same time. This will advance the cursor to the next line where text can also be entered.

Average width defines the average character width (in pixels). A value of 0 means that Windows will use the font's default widths.

The Text field displays the data to be printed. This field can contain between 1 and 255 characters.

The Orientation field determines if the data is printed horizontally or vertically.

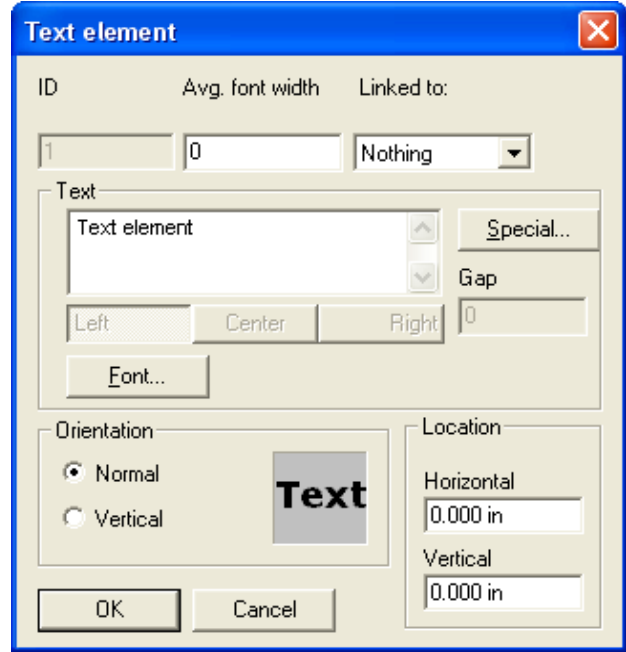

Link to: Allows the user to tie a text element to a barcode element. When the barcode data is changed, the text field will automatically change.

Figure 1: Horizontal orientation



Figure 2: Vertical orientation



To insert special characters, click the **Special** button. This will open the Windows Character Map utility, which can be used to copy and paste special characters.

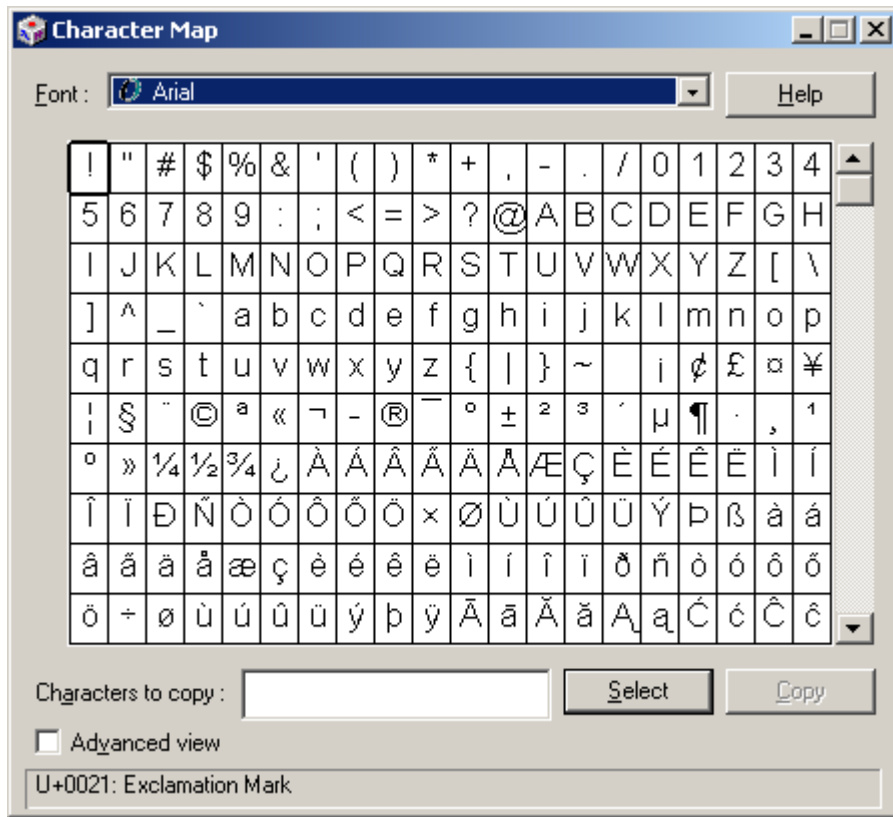

Bitmap

The Bitmap element properties dialog is shown at right.

The Filename field displays the full path and filename of the selected bitmap. To select a different bitmap, click the **Browse** button.

To edit the selected bitmap using the default bitmap editor, click **Edit**. Note that the BoxWriter© Editor will be disabled until the bitmap editor is closed. To change the default bitmap editor, see the *Define, Bitmap Settings* section of this manual.

The Width and Height fields display the size of the bitmap.

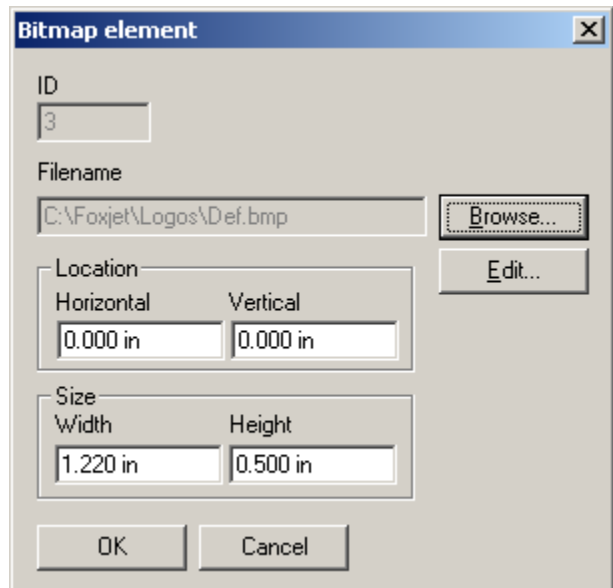

Count

The Count element properties dialog is shown at right.

"Average width" defines the average character width (in pixels). A value of 0 means that Windows will use the font's default widths.

The "Name" field allows the count description to be changed. There can be up to two unique counts.

"Master Count" is the element that can be controlled by Change Count.

"Master" indicates to the software that this count will be controlling all counts throughout the particular message and will lock out the other count settings during the start of the task.

The "Start value" field displays the starting value of the counter.

The "Roll over on" field determines when the counter rolls back to the Start value. (The maximum number of digits for this field is six.)

The "Increment by" field is the number of units added to the current count when a photocell event is fired.

The "Number of digits" field determines the number of significant digits printed. If "Leading zeros" is checked, the count will be padded with zeros. For the example shown here, 000001 would be printed.

The "Orientation" field determines if the data is printed horizontally or vertically. See the *Elements, Text* section for examples of horizontal and vertical text.

For a pallet count, click the "Pallet count" tab and click the **Enabled** button. The "Start value", "Roll over on", and "Increment by" fields' semantics are identical to the ones under the "Box count" tab (see previous example).

The "Units per pallet" field is the number of boxes that are loaded onto one pallet.

The pallet count's Current count is incremented when the Units per pallet value is met. For example, if a pallet holds 144 boxes, this number would be entered into the Units per pallet field. After 144 boxes have been printed, the pallet count would increment.

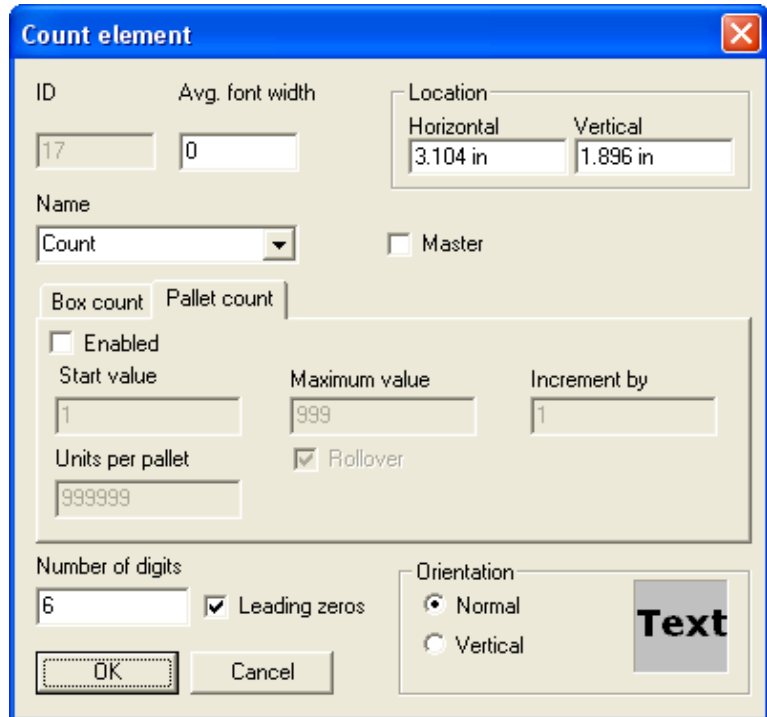

"Rollover" will reset the Pallet count to the Start value when the Maximum value is reached. If unchecked, the Maximum value will be as high as the Pallet count will go.

Date / Time Element

The Date / time element properties dialog is shown at right.

"Avg. font width" defines the average character width (in pixels). A value of 0 means that Windows will use the font's default widths.

The "Format" field determines how the current date or time is printed. For a list of pre-defined formats, see the *Define, Custom Date / Time Formats* section of this manual.

To build a new format, click the **Build** button. For a description of the Build date/time format dialog, see the *Define, Custom Date / Time Formats* section of this manual.

The "Orientation" field determines if the data is printed horizontally or vertically. See the *Text Element* section for examples of horizontal and vertical text.

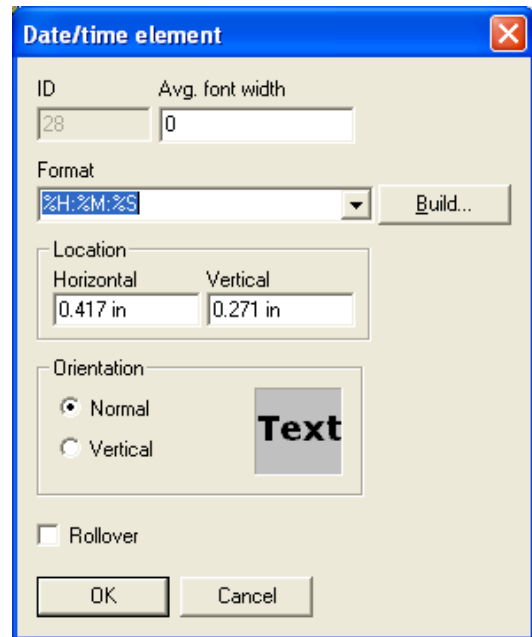

Expiration

The Expiration date element properties dialog is shown at right.

"Avg. font width" defines the average character width (in pixels). A value of 0 means that Windows will use the font's default widths.

The "Format" field determines how the current date or time is printed. For a list of pre-defined formats, see the *Define, Custom Date / Time Formats* section of this manual.

To build a new format, click the **Build** button. For a description of the Build date/time format dialog, see the *Define, Custom Date / Time Formats* section of this manual.

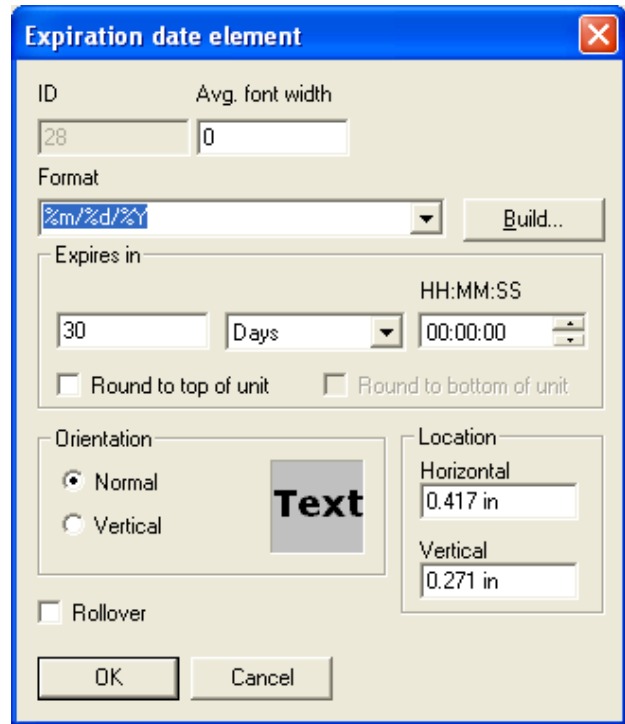

The expiration period is determined by adding the "Days" and "HH:MM:SS" fields to the current system time.

"Round to top of unit" will force the expiration code that is printed to round up to the next whole unit.

The "Orientation" field determines if the data is printed horizontally or vertically. See the *Text Element* section for examples of horizontal and vertical text.

When "Rollover" is selected, the expiration code rollover time can be changed to a different value than midnight. See *Date/Time Codes, Rollover* to enter a new setting.

User

The User element properties dialog is shown at right.

"Avg. font width" defines the average character width (in pixels). A value of 0 means that Windows will use the font's default widths.

The "Data" field displays the data to be printed. If "Use default character" is checked, the data shown in the editor will be drawn with the "W" character. In this example, "WWWWWWWWWWWW-
WWWW" would be displayed in the editor (15 W's, since "Max chars" is set to 15).

If "Prompt at task start" is checked, the operator will be prompted by the Marksman© Pro Control application when the task is started. The data displayed in this prompt is determined by the Prompt field.

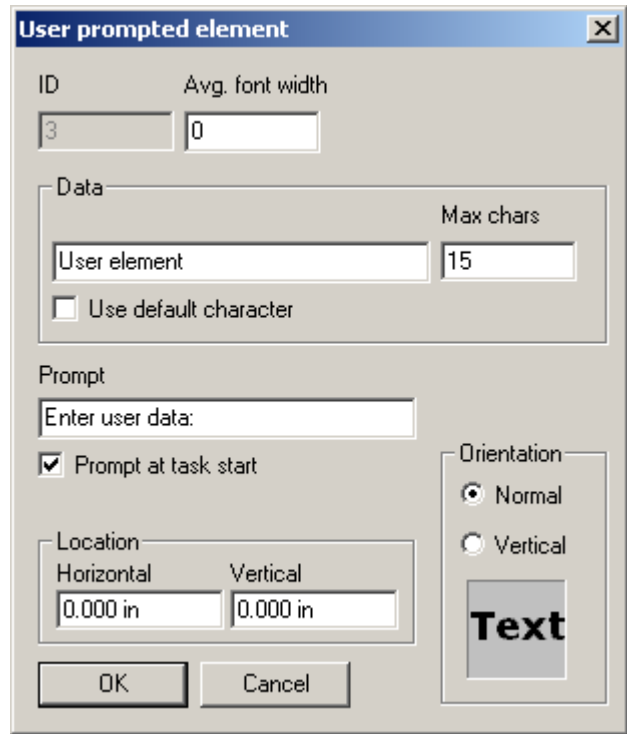

The "Orientation" field determines if the data is printed horizontally or vertically. See the *Text Element* section for examples of horizontal and vertical text.

Shift

The Shift element properties dialog is shown at right.

A Shift element prints the current shift code. See *Define, Shift Codes* for more information.

"Avg. font width" defines the average character width (in pixels). A value of 0 means that Windows will use the font's default widths.

The "Orientation" field determines if the data is printed horizontally or vertically. See the *Text Element* section for examples of horizontal and vertical text.

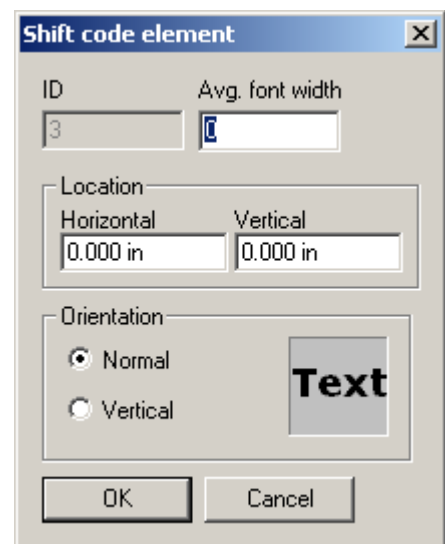

Barcode

The Barcode element properties dialog is shown at right.

The "Symbology" field displays the type of barcode to be printed. The following symbologies are supported:

- I 2of5
- UPCA
- C39
- C93
- C128

The "Magnification" field indicates when set of barcode parameters are used to draw the barcode. See the *Define, Barcode Parameters* section of this manual for information on barcode parameters.

The "Data" field contains the data to be encoded in the barcode.

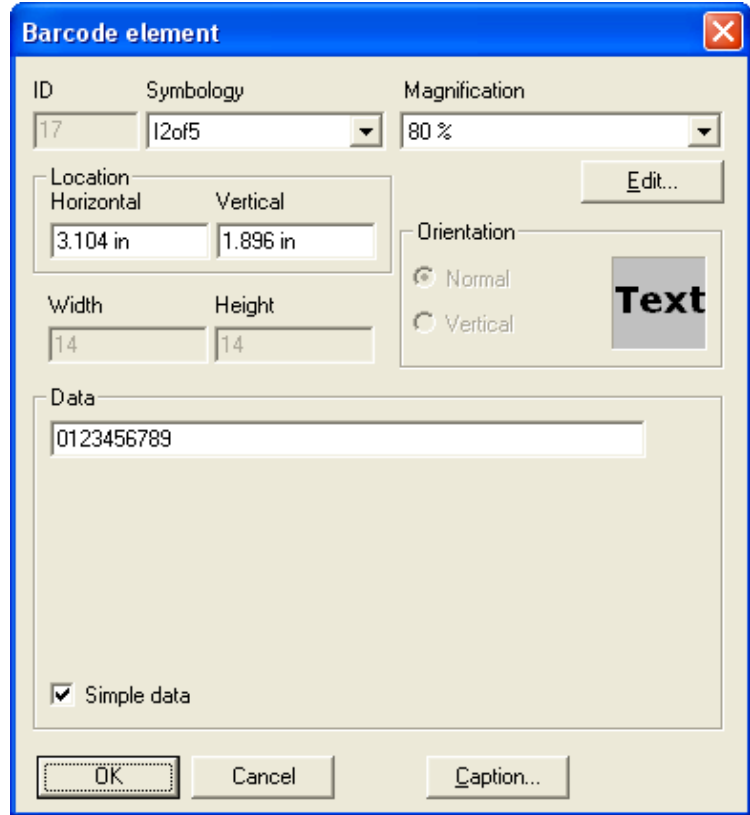

Code 128 barcodes support sub-elements and application identifiers. To modify these, uncheck the "Simple data" box. The following is an example of a Code 128 barcode with two sub elements:

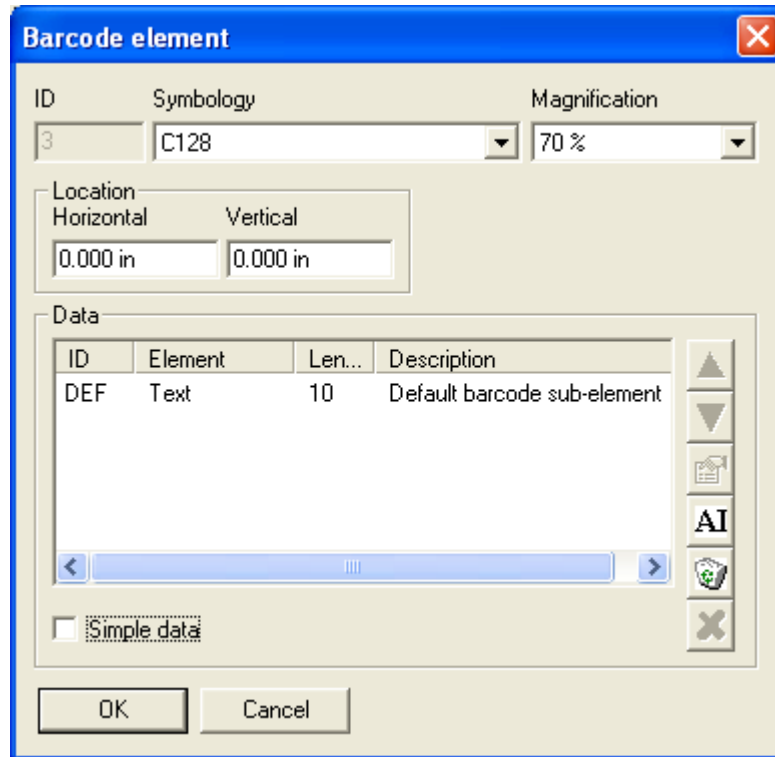

The buttons along the right side of the dialog, from top to bottom, are

- Up - moves the selected sub-element up in the order
- Down - moves the selected sub-element down in the order
- Properties - displays the selected sub-element's properties
- Insert AI - inserts a new application identifier
- Insert sub-element - inserts a new sub element

See the *Define, Sub-elements* and *Define, Application Identifiers* sections for more information.

Database

The Database element properties dialog is shown at right.

A Database element looks up a piece of data from a given database and prints it.

"Avg. font width" defines the average character width (in pixels). A value of 0 means that Windows will use the font's default widths.

The "DSN" field displays the name of the selected ODBC database. To select a different database, click **Browse**. The user will be presented with the "Select Data Source" dialog (see next page).

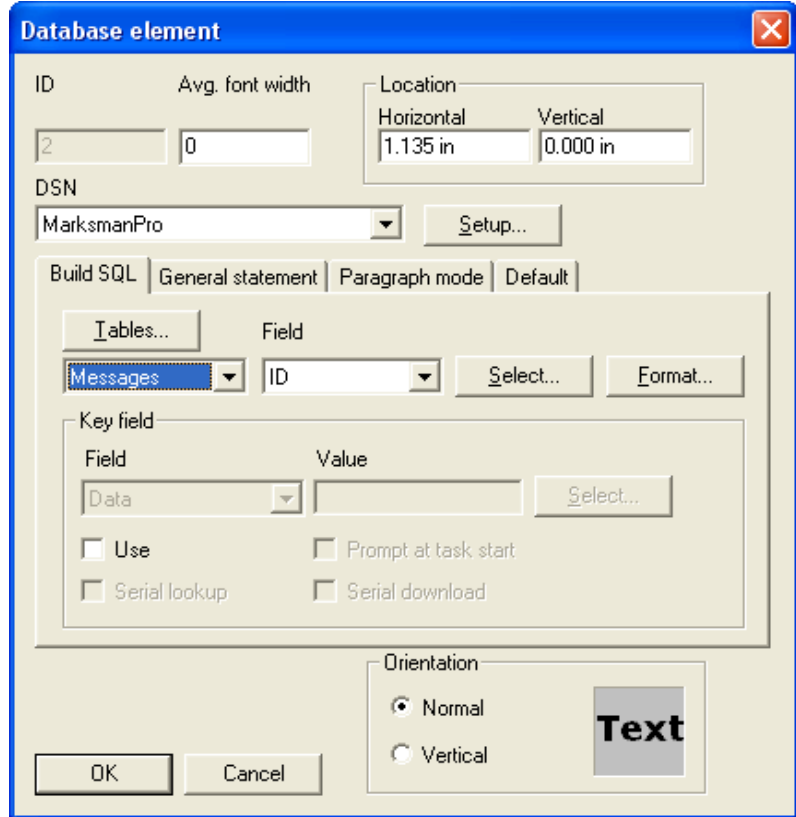

The "Table" field displays the table in the database to query.

The "Field" field displays the field name in the selected table. The value of this field is data that will be printed. The user may also browse the fields in the current table by clicking **Select** (see the Select field dialog on the next page).

If a given record is to be retrieved by a key value, check the "Use" box under "Key field". In this example, the record from the Messages table whose ID is equal to 2434 will be selected. The value of its Name field will be printed. The Key Field may be selected by clicking the "Select" button (see the Select field dialog on the next page).

The "Orientation" field determines if the data is printed horizontally or vertically. See the *Text Element* section for examples of horizontal and vertical text.

The following is an example of what the "Select Data Source" dialog might look like:

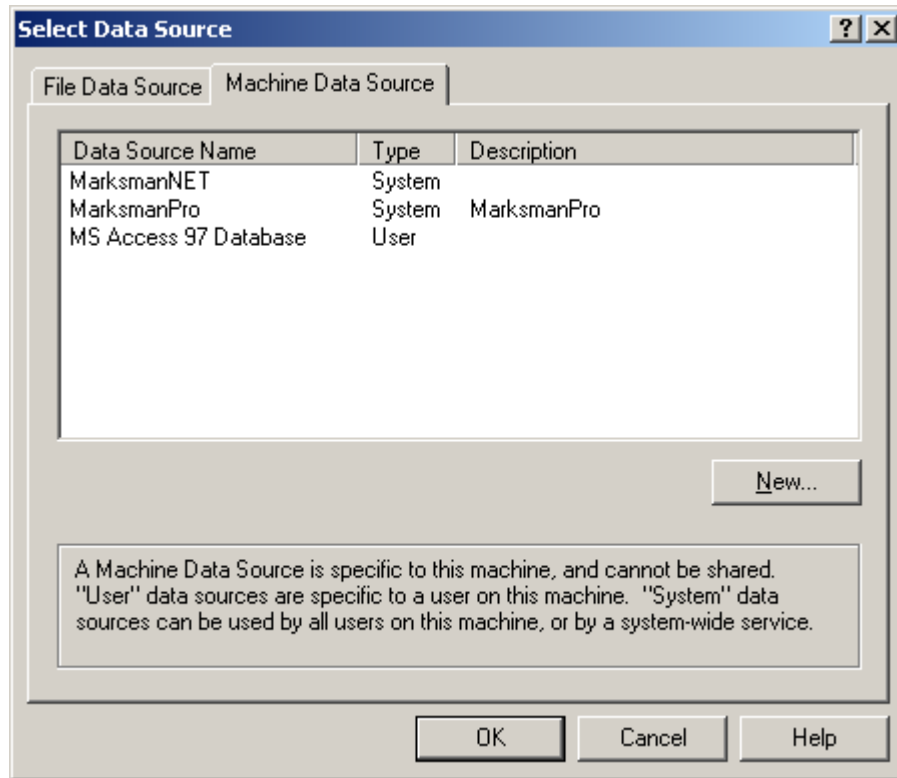

The following is an example of what the "Select field" dialog might look like:

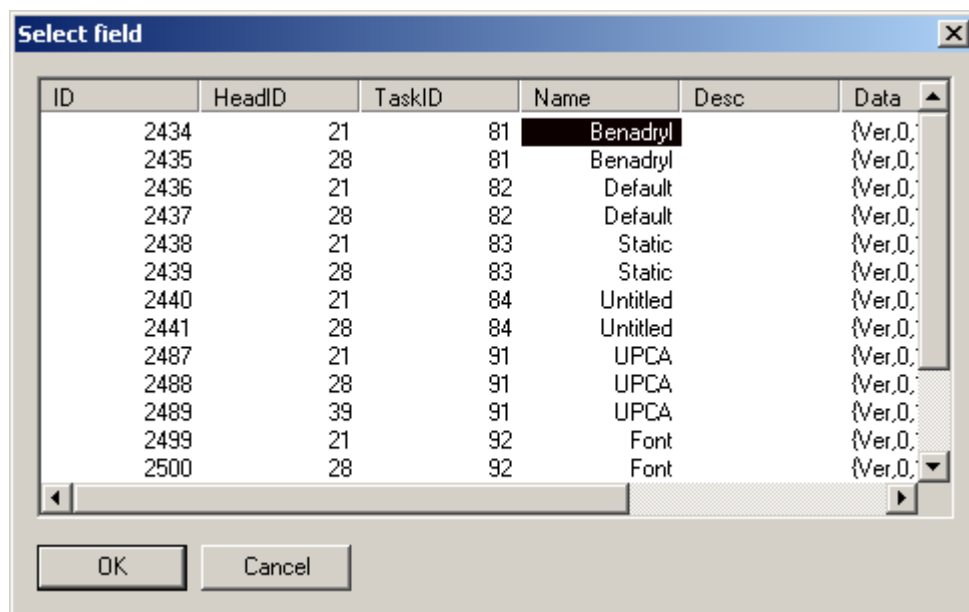

To insert an SQL statement directly, click the "General statement" tab. An example using a general SQL statement is shown at right.

If this option is used, the first field in the first record of the result set will be the data selected to print.

Database element

ID: 28 Avg. font width: 1 Location: Horizontal: 2.438 in, Vertical: 0.042 in

DSN: MarksmanPro Browse...

Build SQL General statement

SQL statement

Orientation: Normal Vertical Text

OK Cancel

Serial

The Serial element properties dialog is shown at right.

A Serial element prints data from the serial buffer. The serial buffer is defined in the Marksman© Pro Control application.

"Avg. font width" defines the average character width (in pixels). A value of 0 means that Windows will use the font's default widths.

The "Start index" specifies the index in the serial buffer to start copying from.

The "Length" field specifies how many characters to copy from the serial buffer.

The "Orientation" field determines if the data is printed horizontally or vertically. See the *Text Element* section for examples of horizontal and vertical text.

In the Editor, a Serial element will be displayed with W's. In this example, it would look like this:

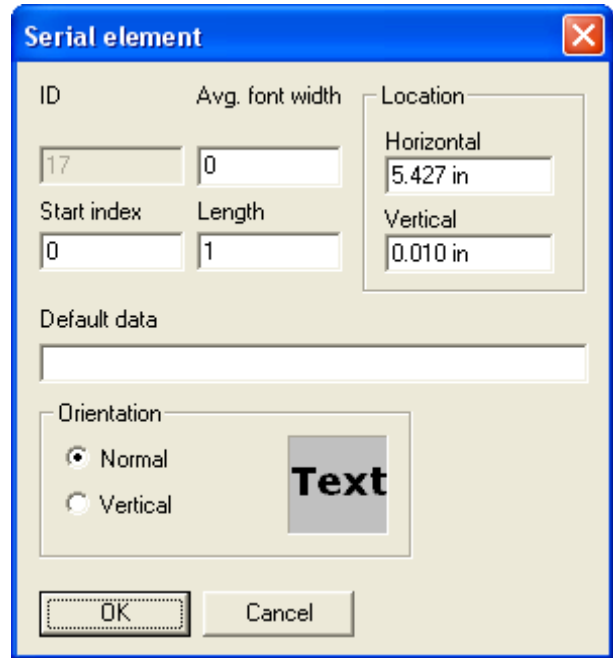

ToolBar



ToolBar icons are listed in the table below in order from left to right:

Button	Menu Command	Keyboard Shortcut
New	File > New	Ctrl + N
Open	File > Open	Ctrl + O
Save	File > Save	Ctrl + S
Save all	File > Save all	
Cut	Edit > Cut	Ctrl + X
Copy	Edit > Copy	Ctrl + C
Paste	Edit > Paste	Ctrl + V
Undo	Edit > Undo	Ctrl + Z
Redo	Edit > Redo	Ctrl + Y
Zoom in	View > Zoom > In	+
Zoom out	View > Zoom > Out	-
Zoom normal	View > Zoom > Normal	
Zoom custom	View > Zoom > Custom	
Fit View to screen	View > Zoom > Fit to Screen	
About	Help > About	F1

New

Creates a new task. See the section on *File, New*.

Open

Opens an existing task. See the section on *File, Open*.

Save

Saves the task currently being edited.

Save All

Saves all open tasks.

Cut

Cuts the selected elements and places them on the clipboard.

Copy

Copies the selected elements to the clipboard.

Paste

Pastes the contents of the clipboard into the current task.

New elements created by this operation will have their position set relative to the current crosshairs position.

Undo

Undoes the most recent operation.

Redo

Redoes the most recent Undo operation.

Zoom In

Zooms the current view in by increments of 25%.

Zoom Out

Zooms the current view out by increments of 25%.

Zoom Normal

Sets the current view's zoom to 100%.

Zoom Custom

This command allows the user to set an arbitrary zoom factor for the current view. Valid zoom factors are in the range of 10% to 200%.

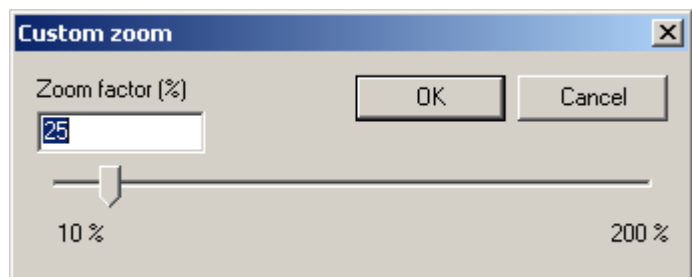

Fit View to Screen

Sets the current view to fit the screen.

About

This command displays the "About" dialog. This dialog lists all the major components of the editor and their version numbers.

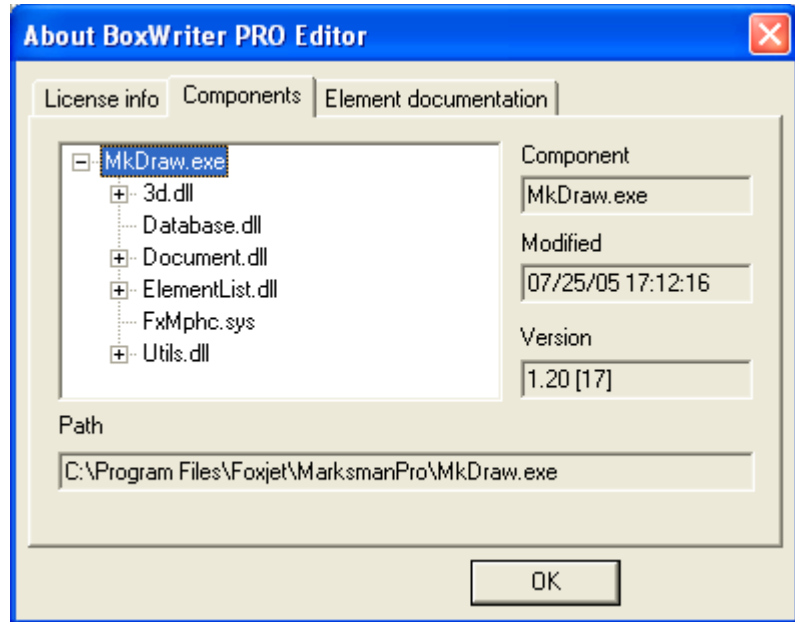

Font bar

The font bar allows the user to change the font properties of any selected elements that have a font (i.e., Text, Count and Date / time elements).



Name

The name of the currently selected font.

Size

The font's height, in pixels.

Width

Defines the average character width, in pixels. A value of 0 means that Windows will use the font's default widths.

If one field overlaps another field, both fields will be highlighted in red.

Rotation Bar

The rotation bar allows the user to change the box's orientation, relative to the print heads.



The buttons rotate the box in the following order (starting from the left-most button):

- Counter-clockwise
- Clockwise
- Down
- Up
- Left
- Right

Following are illustrations of some possible rotations. First, suppose the box has a length, width and height of 12 inches, 6 inches and 3 inches, respectively. By default, it has the following orientation in a new task: 3 inches tall by 6 inches long of printable area:

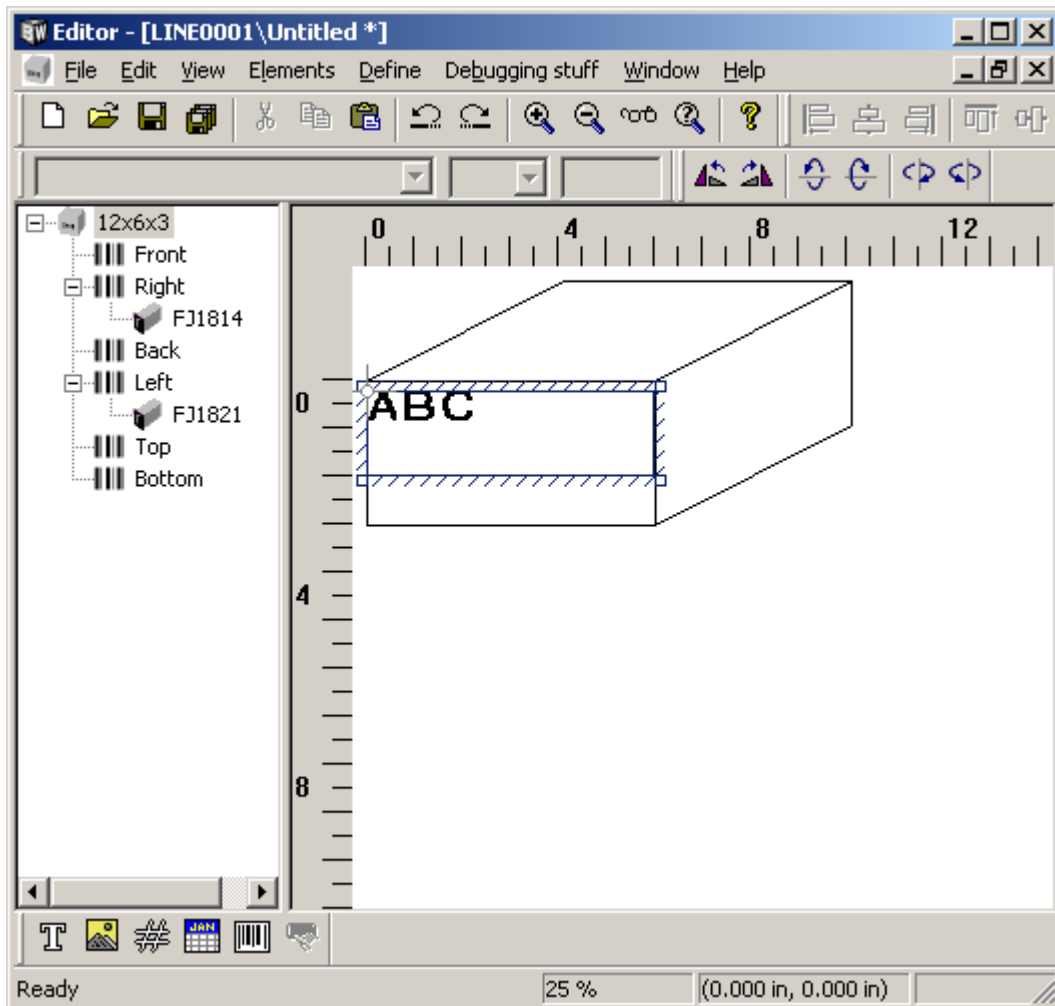

Spinning the box clockwise (or counter clockwise) will result in a printable area that is now 6 inches tall by 3 inches long:

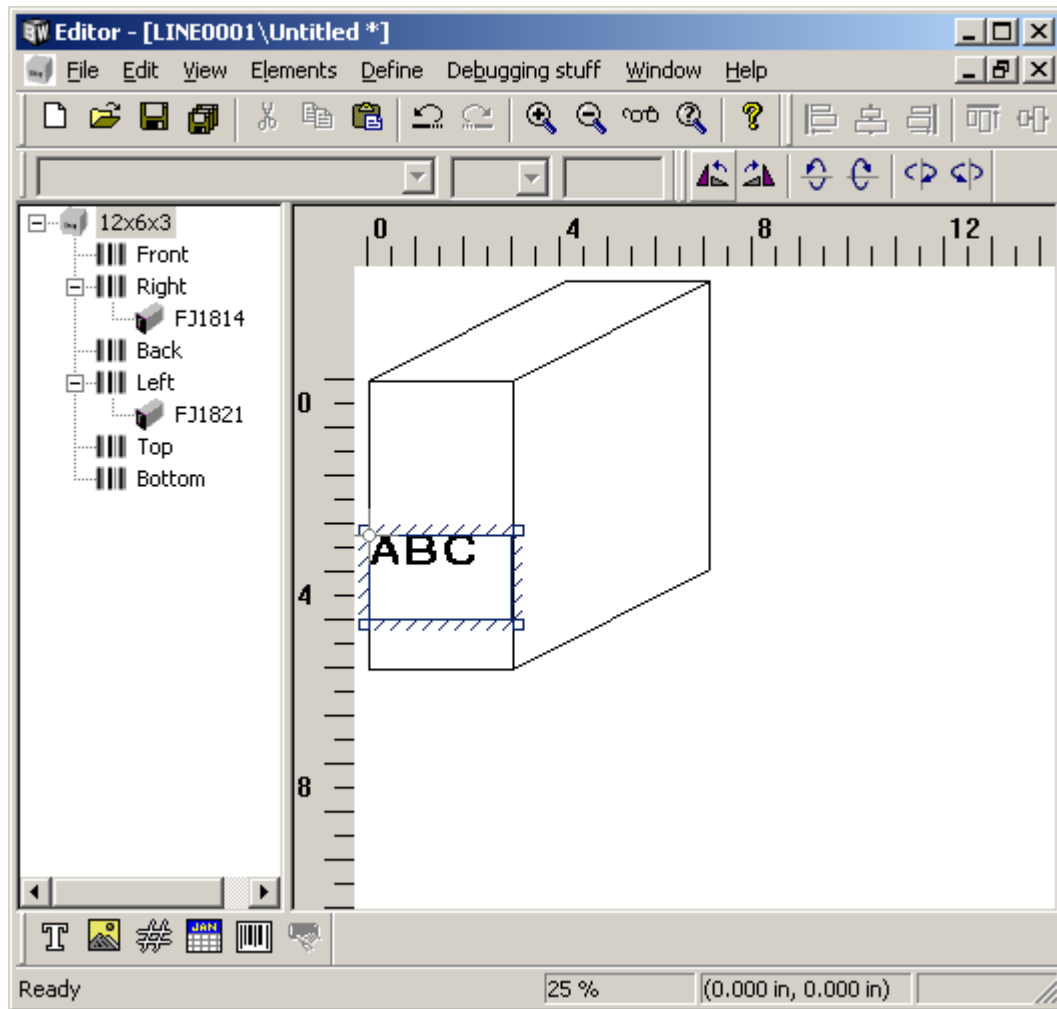

Spinning the box up (or down) will result in a printable area that is now 12 inches tall by 6 inches long:

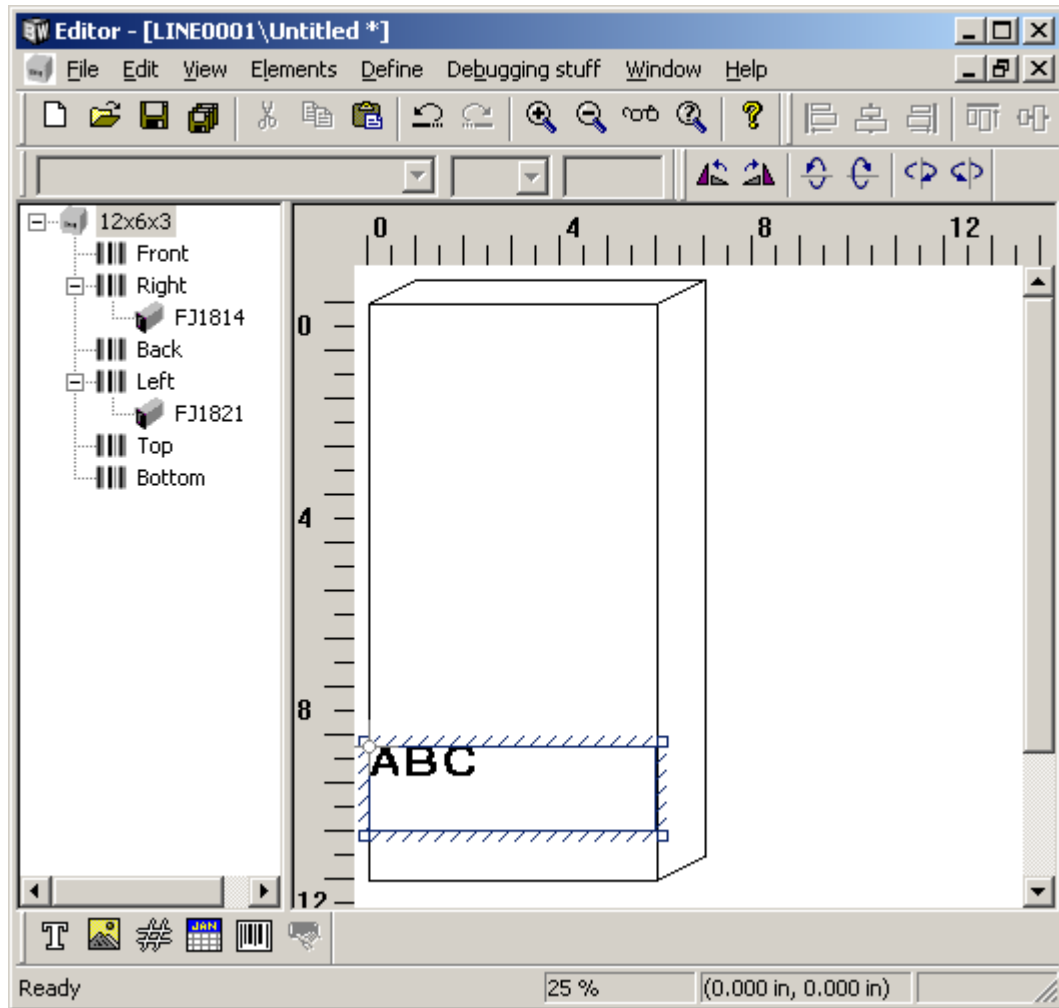

Spinning the box left (or right) will result in a printable area that is now 3 inches tall by 12 inches long:

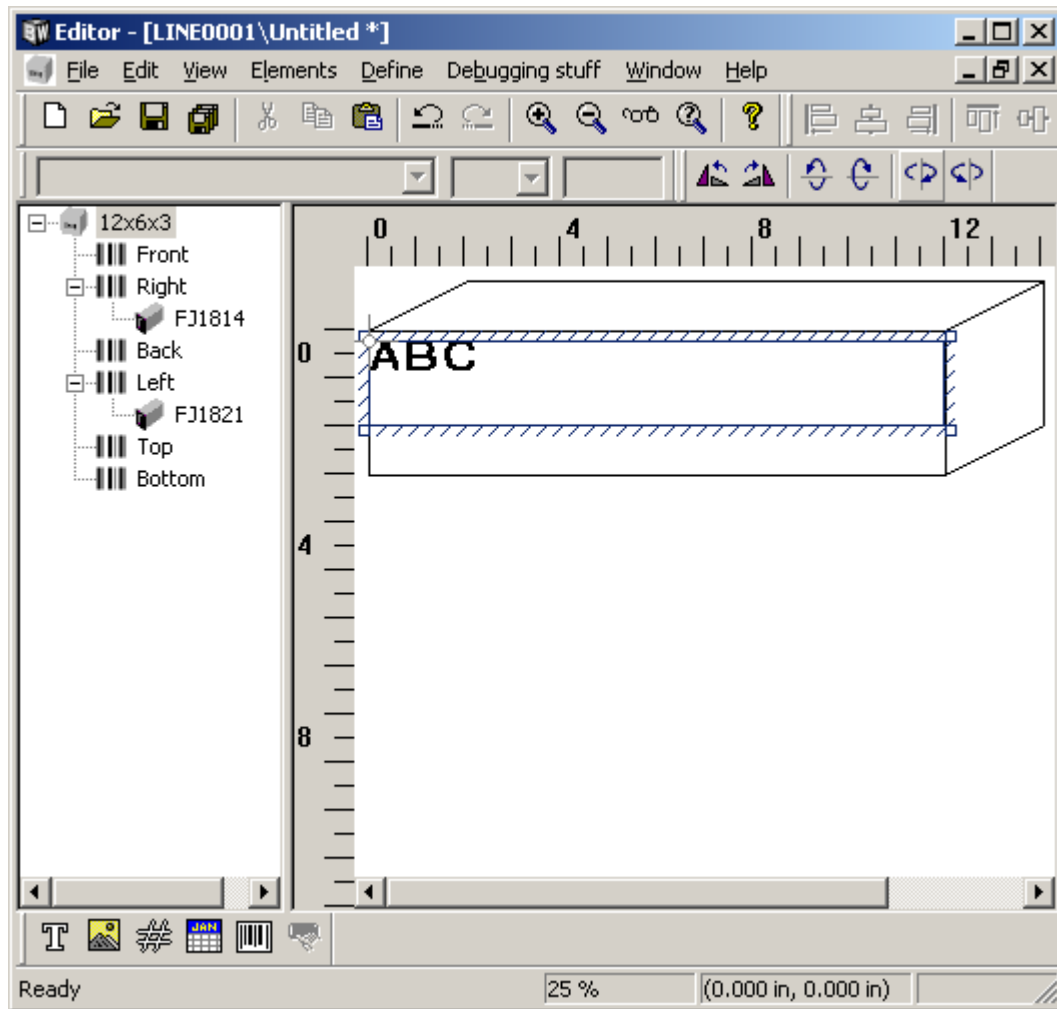

Sometimes changing the box's orientation will result in some elements being forced outside the printable area. When this happens, the Editor will warn the user with the following message:

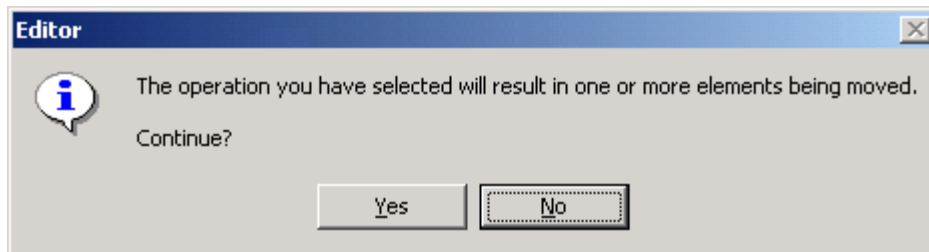

If it is acceptable to move the affected elements, click **Yes** and they will automatically be repositioned. Otherwise, click **No** and the box will be returned to its original orientation.

Alignment Bar

The alignment bar allows the user to apply various transformations to the currently selected elements.



Toolbar icons are listed in the table below in order from left to right:

Button	Keyboard Shortcut	Minimum number of elements that must be selected
Left		2
Center		2
Right		2
Top		2
Middle		2
Bottom		2
Center (on box)		1
Distribute evenly vertically		3
Distribute evenly horizontally		3
Bold	Ctrl + B	1
Italic	Ctrl + I	1
Flip horizontally		1
Flip vertically		1
Inverse		1

Figure 1: Left aligned

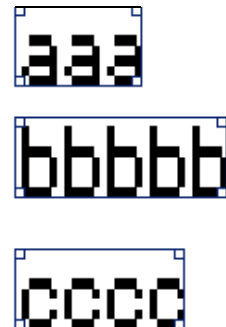

Figure 2: Center aligned

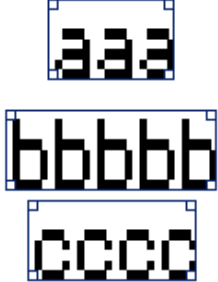

Figure 3: Right aligned



Figure 4: Top aligned



Figure 5: Middle aligned



Figure 6: Bottom aligned



Figure 7: Center (on box)

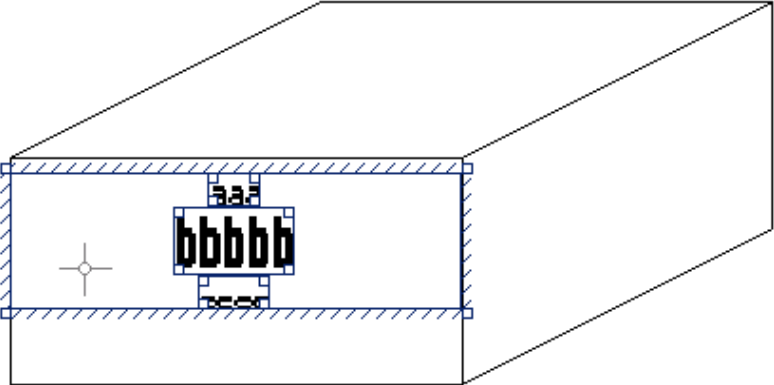

Figure 8: Distribute evenly vertically

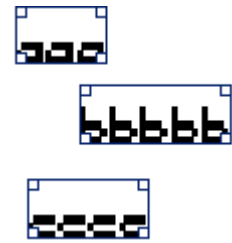

Figure 9: Distribute evenly horizontally



Figure 10: Text element with no bold factor



Figure 11: Bold factor of 3

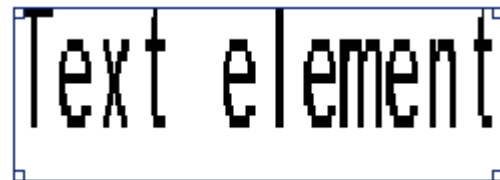

Figure 12: Flip horizontally

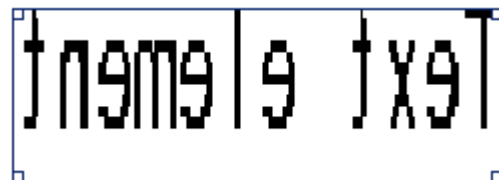

Figure 13: Flip vertically

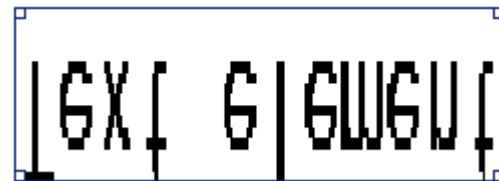
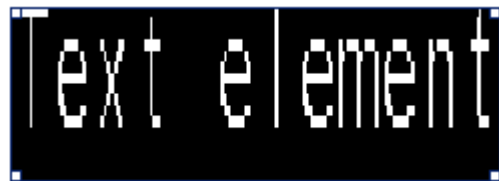

Figure 14: Inverse



Perspective

To change the perspective of the box view, select **View > Change perspective**.

The x and y axis perspectives must be between -90 and 90 degrees.

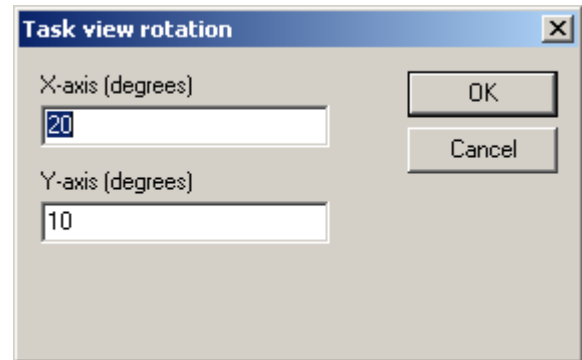

Figure 1: Perspective as viewed with [x, y] set to 20, 10

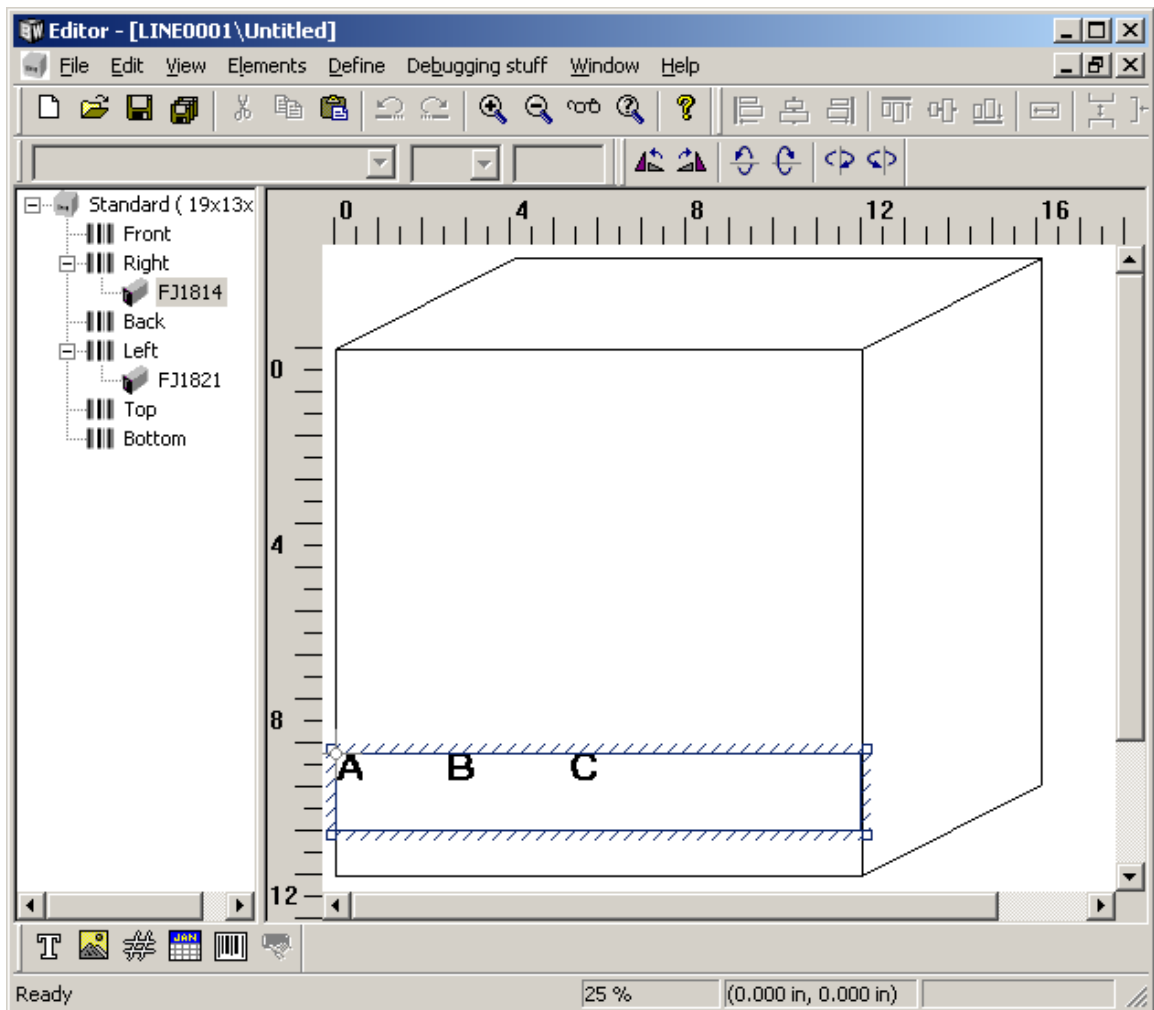
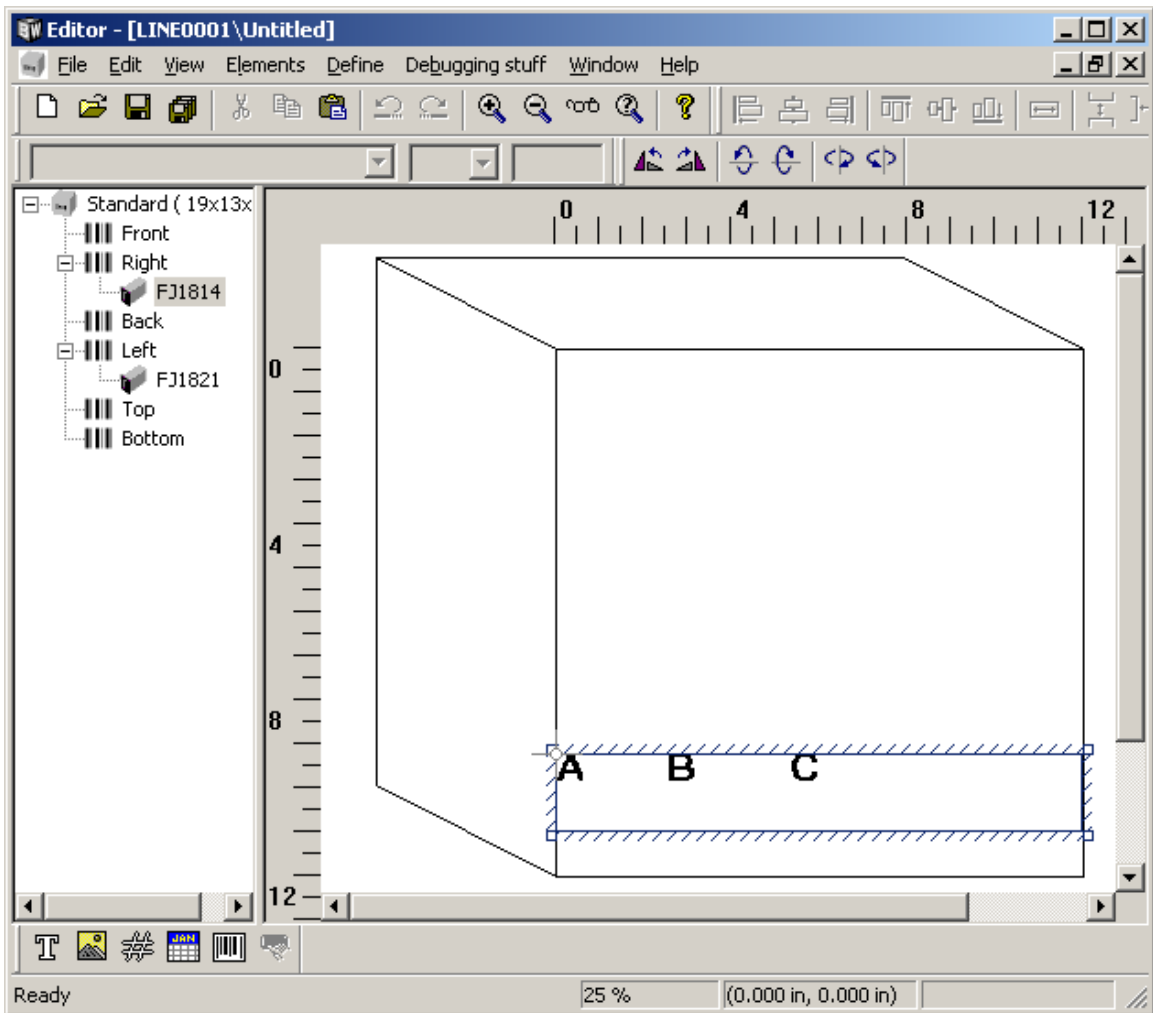

Figure 2: Perspective as viewed with [x, y] set to -20, 10



Section 8: Maintenance

APS - Automatic Priming System



NOTE: The system will not prime either manually or automatically if there is a low ink indication. Low ink indication is caused by either low ink in the reservoir or full ink in the waste collection bottle.

The APS is an invaluable tool for routine cleaning of loose debris from the print engine face. The images below demonstrate print before and after the APS.



BEFORE APS



AFTER APS



NOTE: The duration of the APS cycle is approximately 5 - 10 seconds.

Shutdown Procedures

- Close the Application (double-click the **X** in the upper right hand corner).



NOTE: You must have the proper security level before the application will close.

- When Windows® is at the desktop, select **Start**, then select **Turn Off Computer**.
- Select **Turn Off Computer** (Windows® will perform its shutdown sequence).
- When Windows® is done, the screen will be all white.
- It is now safe to turn the power off.

Daily - 8 Hours

- Dust touch screen and keyboard with lint-free cloth.
- Make sure the cabinet fan(s) are working.
- inspect print head assemblies for leaks and wipe with lint-free cloth as necessary.



NOTE: Do not wipe the print head faceplate!

- Inspect for broken or worn electrical connections.
- If missing channels occur in printed message, purge print head.

Inspect guide box rails and print head bracket for wear.

Overnight and 1 to 3 Days:

Idle the system through the software to avoid any misprinting. It's OK to leave the system powered up during this time.

Use the priming and purging procedure after this period of inactivity to remove any dust or debris that might have collected on the print head faceplate.

Periods of More Than 3 Days:

If the heads are not to be used for longer than three days, it is recommend that the controller be turned off.

- Exit the software.
- Power the system down.
- Close the reservoir vent cap.
- Replace the Ship Cap.

Upon power up, allow the head to heat up and perform a visual inspection on the heads before using. Run an APS cycle to insure all the channels are clear.

- Remove the Ship Cap.
- Open the reservoir vent cap.
- Power up the system.
- Use one of the priming procedures to remove any air or debris that may have entered the print head or faceplate.

3 Weeks - 120 hours

- Wipe print head cases and ink reservoir covers with lint-free cloth.
- Clean printer cabinet with cloth to remove dust.
- Have qualified person open printer cabinet and inspect for dust. If necessary, blow out dust with low-pressure air that is moisture- and oil-free.
- Inspect the fan filter and replace if necessary. See below for procedure.
- Make sure the fan turns freely.

3 Months - 500 hours

- Wipe print head cases and ink reservoir covers with lint-free cloth.



NOTE: Do not wipe the print head faceplate!

- Clean printer cabinet with cloth to remove dust.
- Have qualified person open printer cabinet and inspect for dust. If necessary, blow out dust with low-pressure air that is moisture- and oil-free.
- Replace fan filter and inspect for bearing wear. Replace if necessary. To replace the fan filter, simply remove the louver plates on the outside side panels of the Marksman®. The filter is located under this plate. The fan filter can be cleaned with low-pressure air. For thorough cleaning, clean with soap and water and allow to dry before re-installing.
- With the printer off, make sure tie wraps securely hold all cables. Replace any missing tie wraps or damaged cables.

Section 9: Troubleshooting

The Marksman© Pro ink jet system incorporates advanced designs, both in hardware and in software. However, if the system ever fails to perform properly, some built-in indicators will help in troubleshooting. This section will help minimize system downtime and explain some of the diagnostic features built into the system.

Troubleshooting Notes

Most controller problems will be the result of improperly connected cables. Check all connections, including power interface, print heads, encoder, and photosensor. (See *Appendix B, Theory of Operation* for details.)

Problem: Cannot communicate to the Marksman© Pro through the Ethernet.

Action:

- Power down, then power up the computer and the Marksman© Pro.
- Check for proper Ethernet cabling.
- Verify that the IP addresses are valid for the computer and the Marksman© Pro.

Problem: The system does not print.

Action:

- Check that there are no errors on the head.
- Check that the encoder is active.
- Check that the photocell is enabled, sensing a product.
- Check that the configuration is correct for the head being used.
- Check that a valid label is selected.

Problem: No Shaft Encoder.

Action:

- Make sure that the encoder wheel is contacting the conveyor.
- Make sure that the encoder is connected and plugged into the proper port.
- Check the configuration for proper setup.

Troubleshooting Tests

Print Test

This test will determine if the print heads are printing.

1. Place a cloth in front of the print head front plate.
2. Initiate a print cycle by turning on conveyor and tripping the photocell.
3. Check for ink on cloth.

Printed dots on cloth indicate that the system is printing. Check product sensor offset settings, product length, or product margins if print is not seen on carton.

No ink on cloth indicates that the system is not printing. Review system status to determine other possible causes of system not printing, including a test of the photosensor and encoder to ensure operation.

Photosensor Sensitivity Test

This test will determine if the photosensor sensitivity is adjusted correctly for the application.



NOTE: The test object should be a sample of the actual product.

1. Place the test object approximately $\frac{1}{4}$ inch in front of photosensor; photosensor should sense object.
2. Place the test object near the center of the guide rails; photosensor should sense object.
3. Place the test object on far guide rail; photosensor should not sense object.
4. Check that objects on the far side of the conveyor do not trip the photosensor.
5. Check that color differences in product do not cause multiple photosensor trips at the farthest sensing distance.



NOTE: If the red LED on the photosensor fails to illuminate when an object is placed in front of (but not touching) it, this is an indication that the photosensor is disconnected, or the power supply or photosensor has failed.

Print Quality Troubleshooting

This section shows examples of various print problems and actions which should be taken to improve the print.

Problem: Minor fractures in print channels.

Possible Cause: Debris on front plate, air in channel.

Action: Run APS. Add brushes and positive air flow to minimize debris build-up.



Problem: Missing channels and channel fractures in print channels.

Possible Cause: Excessive debris on front plate, air in channel.

Action: Wipe front plate and run APS. Add brushes and positive air flow to minimize debris build-up.



Problem: Missing print channels.

Possible Cause: Air in channel.

Action: Run APS. If air cannot be removed, run a Prime Cycle per instructions in *Section 4: Installation*.



Problem: Missing bottom print channels.

Possible Cause: Ink build-up on lower orifices.

Action: Wipe front plate and run APS.

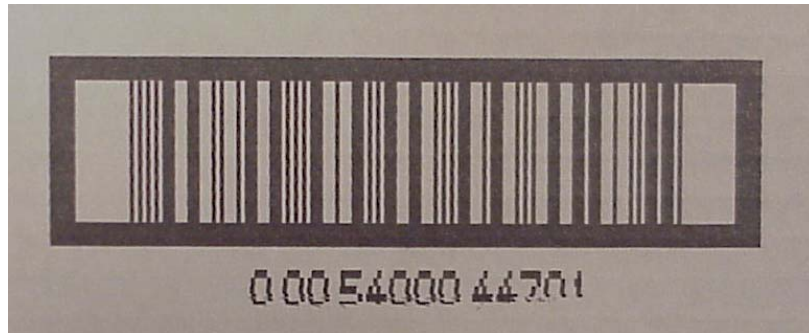

Problem: Fuzzy print.

Possible Cause: Print head too far away from substrate.

Action: Move print head to within 1/8" from product.

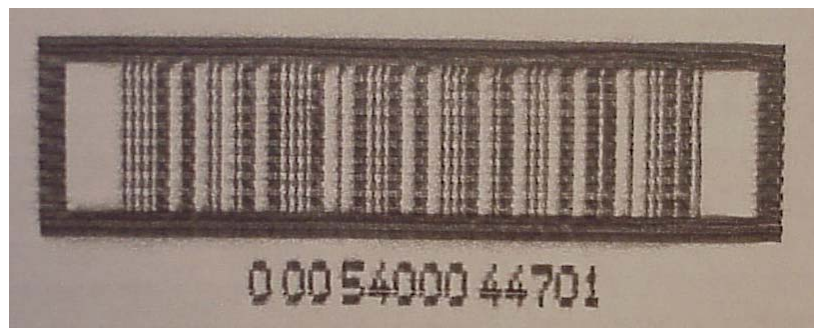

Problem: Occasional checkerboard print pattern.

Possible Cause: Encoder slipping or bouncing on belt.

Action: Tighten encoder on belt; replace encoder o-rings, if required; or replace conveyor belt with a smooth seamless belt.



Problem: Stretched out, light print, checkerboard pattern.

Possible Cause: Incorrect encoder, or incorrect line speed (set too low) if using internal encoder.

Action: Check for correct encoder (use 5000 PPR Encoder).

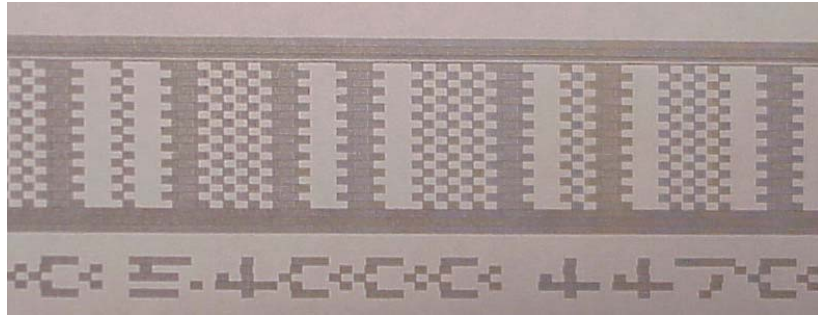

Problem: Short image, dark print, checkerboard pattern.

Possible Cause: Incorrect encoder or wheel size, or incorrect line speed (set too high) if using internal encoder.

Action: Check for correct encoder (use 5000 PPR Encoder).

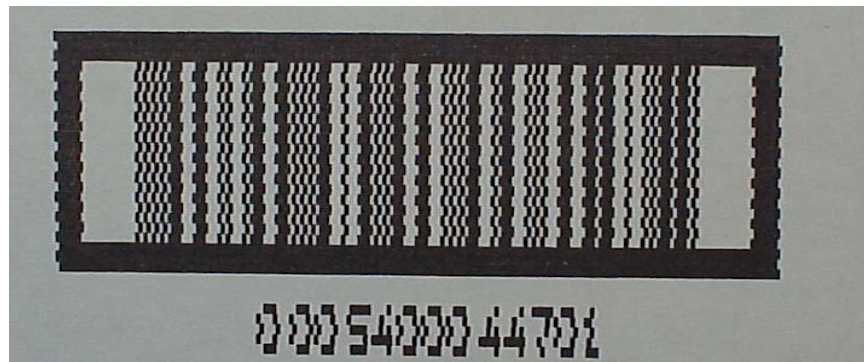

Appendix A: Specifications

Controller Specifications

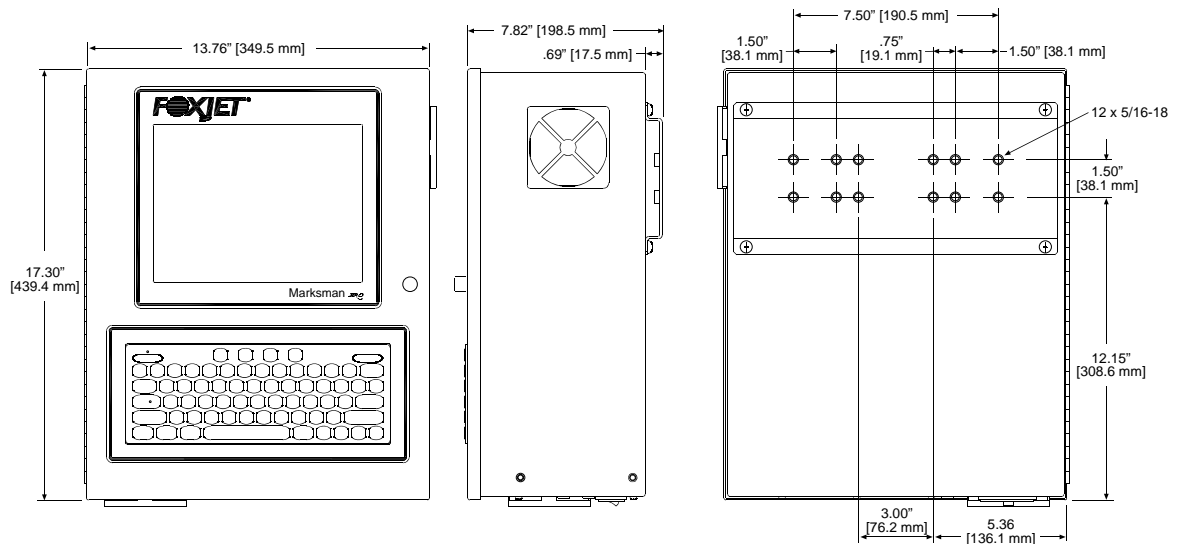

- Processor: SBC 667 MHz or 800 MHz with 128 MB RAM
- Power Input: 100-240VAC, 50-60Hz at 3A max
- Ports:
 - COM 1 - Serial Port RS232
 - APS
 - 10/100 Base-T Ethernet
 - Print head, ProSeries (up to six heads)
 - Encoder A
 - Encoder B
 - Strobe
 - Auxiliary Port - Serial Port (Scanner)
 - VGA Output
 - Keyboard/MS Mouse
- Enclosure: Stainless Steel
- Weight (Controller only): 28.4 lbs. (12.9 kg)
- Operating System: Windows XP®
- Environment:
 - Ambient operating temperature: 40° to 104° F (5° to 40° C)
 - Operating humidity: 10-90%, non-condensing
- Print Heads: ProSeries up to 6 ProSeries Print Heads (96, 192, 352), or up to 4 ProSeries Print Heads (384 or 768)
- Storage: 80 GB hard drive
- Alarms: Optional beacon
- User Interface:
 - Type: Graphical User Interface
 - Keyboard: 70-Key, QWERTY style, Elastomeric Keyboard
 - Display: 640 x 480 color LCD with touch screen, 10.4" diagonal
- Print Head to Controller: Maximum distance between print head and controller is 25 feet

Print Head Specifications

96, 192 and 352 Print Heads:

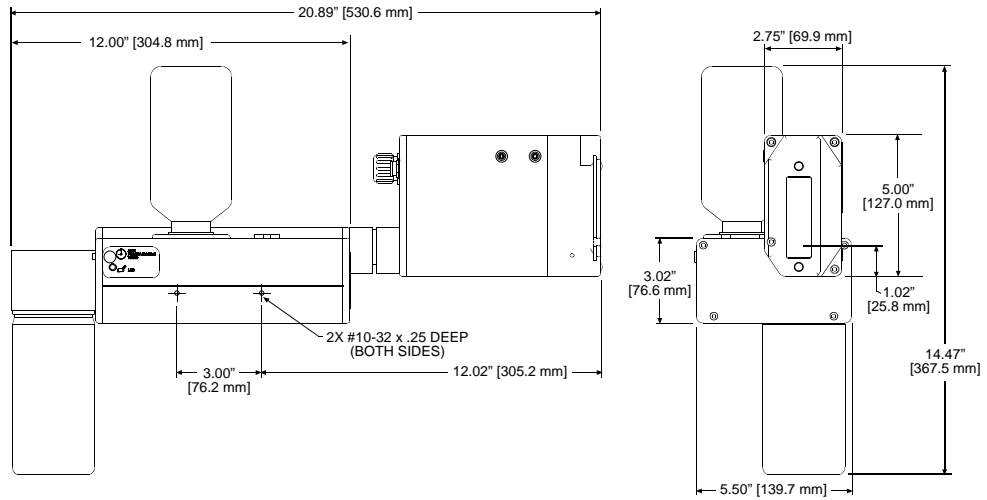

384 Print Head:

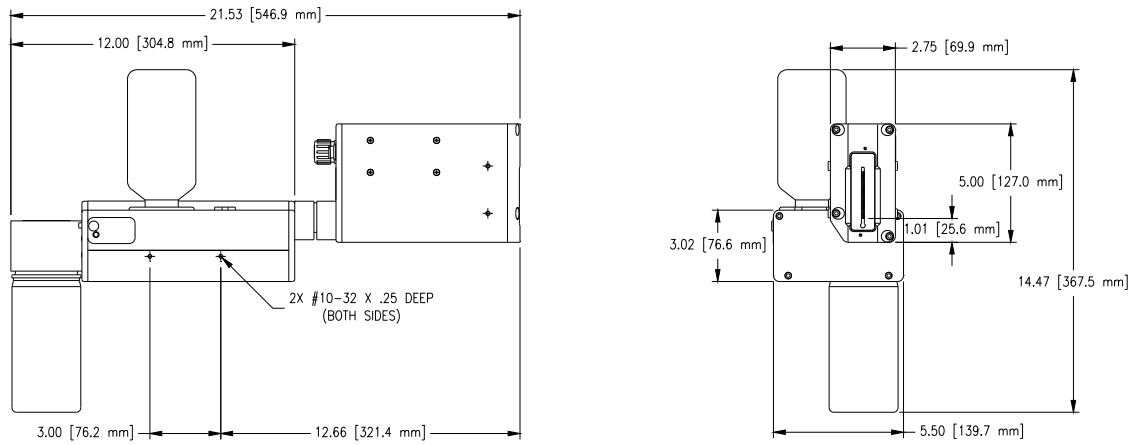

768 Print Head:

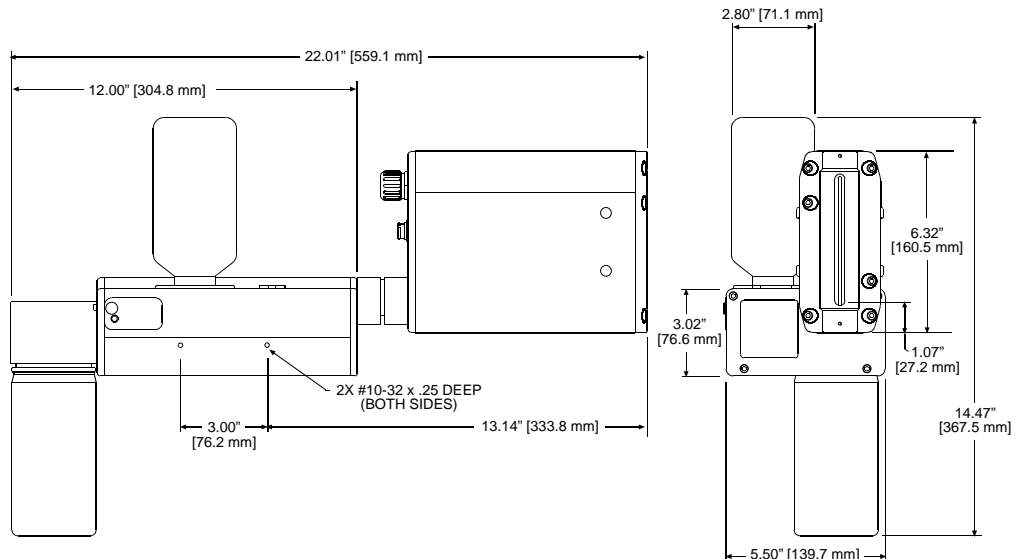

AlphaCoder Head:

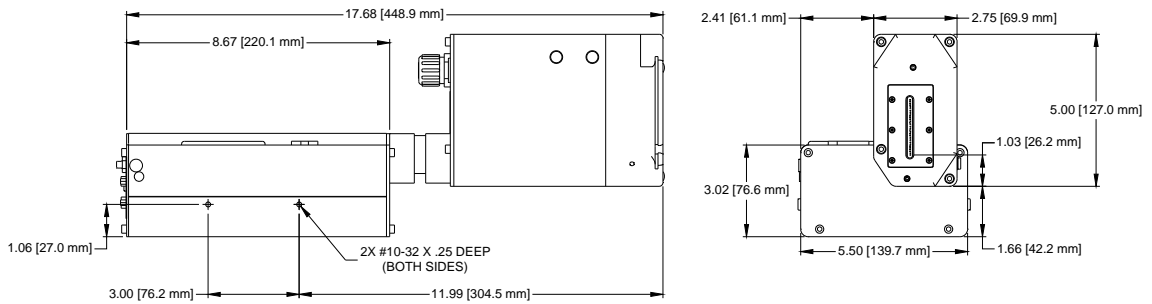

- Electrical Connections: Standard 30" (.76m) length
 Optional 25' (7.5m) length extension cable
- Print Orientation: Integrated - Horizontal or horizontal angle (for incline printing)
- Ink System: Non-pressurized capillary feed technology
 Priming: Automatic Priming System (not included with Alpha-Coder Print Heads)
 Float switch sensor: Low ink and full waste bottle detection (waste detection not included with AlphaCoder Print Heads)
- Ink Specifications: ScanTrue II® (192, 384, 768 and AlphaCoder Print Heads), Pigmented oil-based for porous surfaces
 VersaPrint™ V300 (192 and 352 Print Heads), Glycol-oil based for porous surfaces

Technical Data:

	192 Head	352 Head	384 Head	768 Head	AlphaCoder Head
Image Area:	.2" - 1" (5 - 25mm)	.38" - 1.9" (10 - 48mm)	.38" - 2" (10 - 51mm)	.38" - 4" (10 - 102mm)	.75" - 1.9" (19 - 48mm)
Channels:	32	32	128	256	32
Orifices:	192	352	384	768	224
Horizontal Resolution:	150 or 300 dpi	150 or 300 dpi	150 or 300 dpi	150 or 300 dpi	150 or 300 dpi
Lines of Print:	1 - 5	1 - 5	1 - 21	1 - 42	1 - 5

- Operating Conditions: Temperature: 50° - 104° F (10° - 40° C)
 Relative Humidity: 20 - 80% (non-condensing)
- Storage Conditions: Temperature: 32° - 109°F (0° - 43° C)
 Relative Humidity: 20 - 80% (non-condensing)

Appendix B: Theory of Operation

The Marksman© Pro

The Marksman© Pro is a high-resolution ink jet coder used to print fixed and/or variable information onto cartons as they pass in front of the print heads on a conveyor. The Marksman© Pro is an industrial PC-based controller that uses a single board computer (SBC) running Windows XP® to process and generate the images to be printed. Included on the SBC are all the peripherals associated with a computer, such as the video controller and Ethernet controller. In addition to the SBC, there are print head cards (PHC), one for each head. The PHC is responsible for converting the data from the SBC to something that the head can use to print. It also regulates the temperature of the head and relays head status information from the head to the SBC. When the data is put in a form that the head can use it is sent through the print head cable (DB25) to the head as needed.

Messages are entered using the on-board keypad and touch screen display and stored on the system's hard drive. The information is recalled as needed when a task has been selected. The power needed for the system is generated from two different power supplies. One generates the +5V and +12V needed for the logic circuits and the other generates the +24V required for the head heaters and the DC-DC converter.

Print Heads

The Marksman© Pro supports all the Pro series printheads. A typical printhead includes a reservoir section, drive electronics, and a print engine. The information and power needed for printing are sent to the print head through the DB25. The DB9 is used for APS control.

The drive electronics include a Universal Driver Board and Marksman© Driver Board. The Universal Board takes 24VDC and generates the high voltage needed by the print engine. The Marksman© Driver Board (only on UJII engines) converts the serial data from the controller to parallel high voltage data required to control the print engine channels.

The **APS** includes an ink collection bottle, vacuum pump, APS board, purge pump and reservoir. The APS cycle is controlled by the Marksman© Pro via a DB9 cable. Parameters are set through the software. It is important for the cable to be connected. The power and low ink signals are sent to the Marksman© Pro through the DB25 cable. The ink collection bottle stores the used ink from the APS cycles. If the bottle becomes full, or the reservoir is low, the APS is disabled and the error LED is set.

Photosensor

The photosensor detects a product as it passes in front of the sensor. The signal starts the printing process. Once the printing process has started it will continue until the label is complete, regardless of what the photosensor signal does.

Encoder

The encoder is used to signal the controller when to print another column of ink. There are two encoder options, external or internal. The external encoder rides on the conveyor to determine how often to print a column of ink. As the conveyor's speed changes, so will the period of time between the printing of the columns of ink. The internal encoder is timed-based so that if the speed of the conveyor changes the print will be stretched or compressed until the encoder speed is corrected.

Wiring Diagram - Marksman Pro Rev A through K

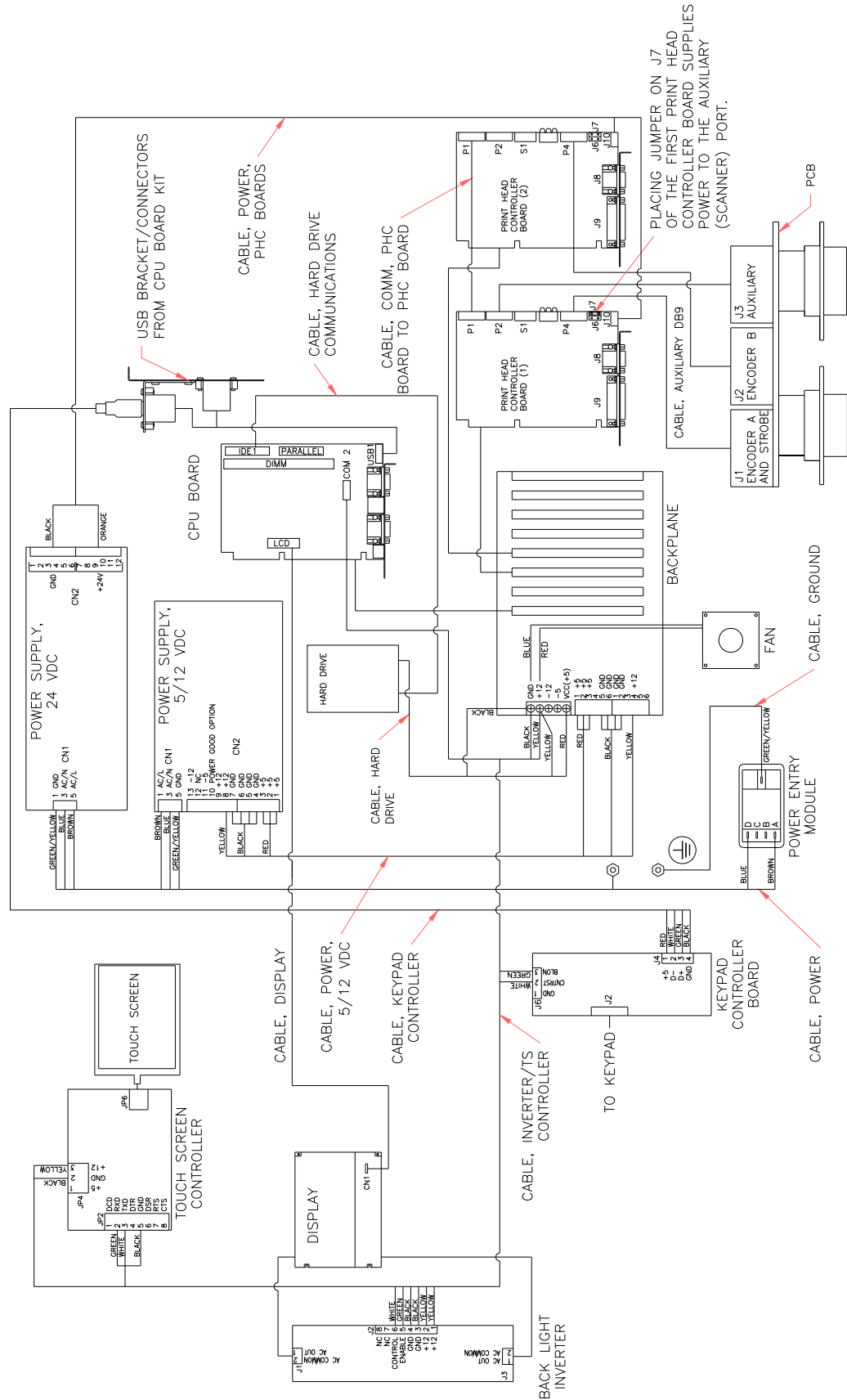

Wiring Diagram - Marksman Pro Rev L & Higher

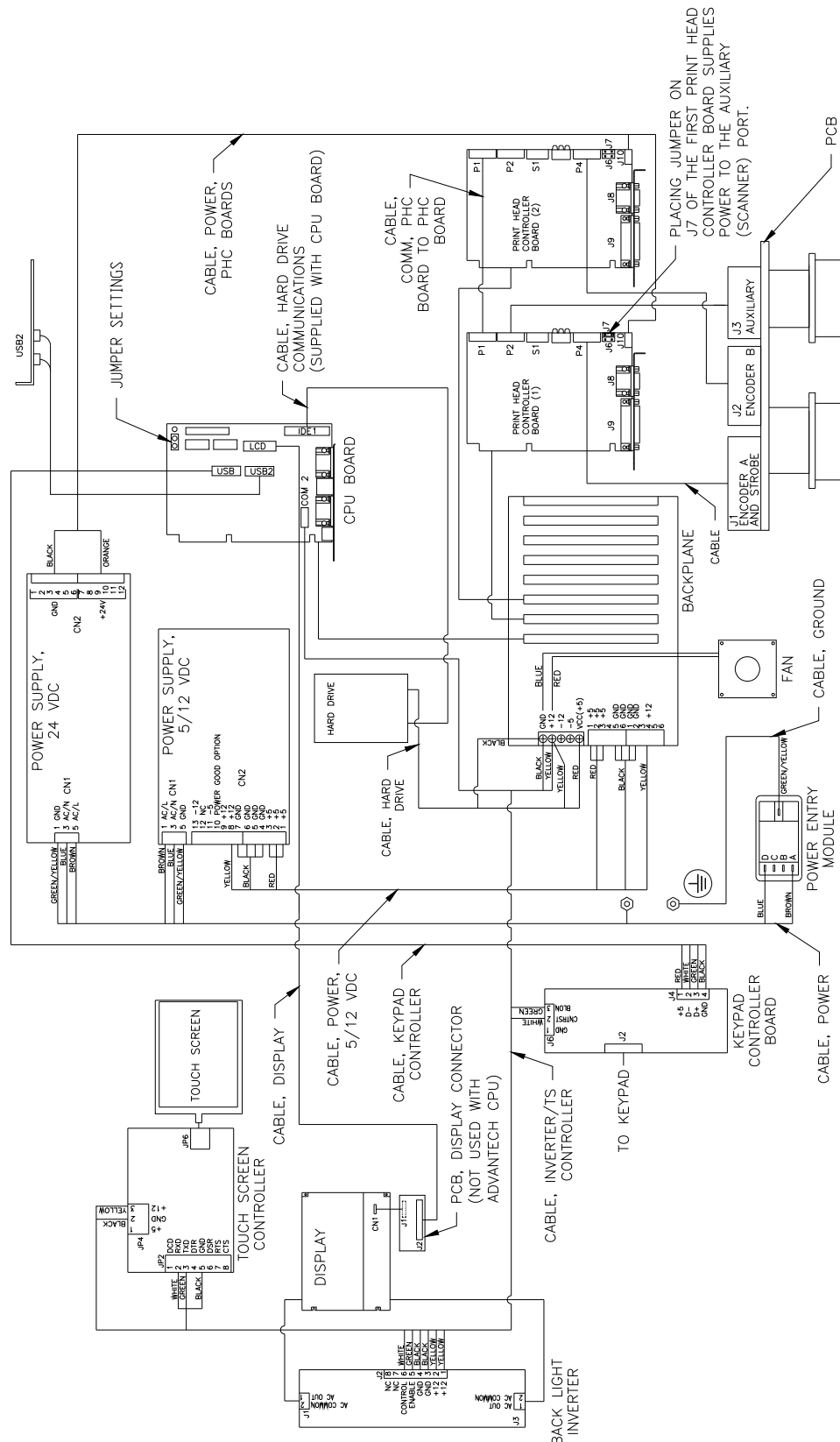

Appendix C: Parts and Supplies

Consumables

Part Number	Description
001-0732-01F	Ink, 500ML V300 Black
001-0598-01F	Ink, ScanTrue II®
032-6001-01	Ink, 500mL Bottle, AlphaMark
2464619	Kit, Ink Waste Bottle, V300 Ink (APS only)
2464620	Kit, Ink Waste Bottle, ScanTrue II® Ink
2464621	Kit, Vent Filter Replacement
X30001-001	Print Head Wiping Cloth (300/pkg)

Controller Assembly Service Kits

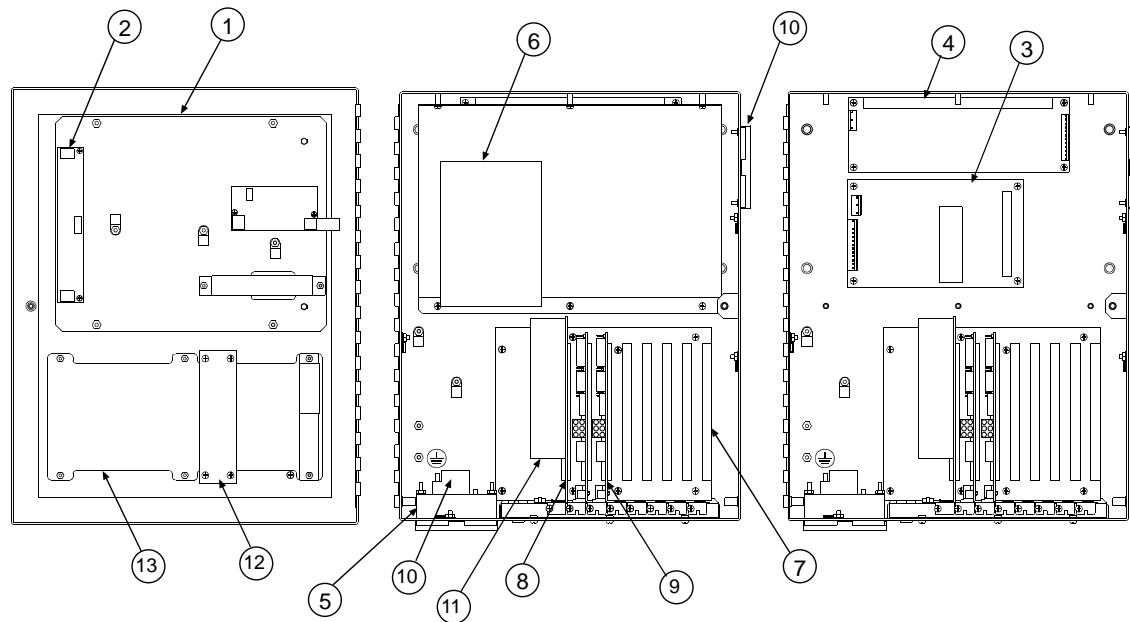

ITEM NO.	PART NO.	DESCRIPTION
1	2465202	Display/Touch Screen Replacement Kit
2	2465203	Back Light Inverter Replacement Kit
3	2465205	Power Supply Replacement Kit, 5/12 VDC
4	2465206	Power Supply Replacement Kit, 24 VDC
5	2465207	Fan Replacement Kit
6	2465208	Hard Drive Replacement Kit (for MKPro Rev A through K)
6	2465233	Hard Drive Replacement Kit (for MKPro Rev L and higher)
7	2465209	Backplane Replacement Kit
8	2465210	CPU Board Replacement Kit (for MKPro Rev A through K)
8	2465231	CPU Board Replacement Kit (for MKPro Rev L and higher)
9	2465211	PHC Board Replacement/Upgrade Kit
10	2465214	Fan Filter/Fuses Kit (5 Filters, 4 Fuses)
11	2465215	Memory Replacement Kit (for MKPro Rev A through K)
11	2465232	Memory Replacement Kit (for MKPro Rev L and higher)
12	2465216	Keypad Controller Board Replacement Kit
13	2465217	Keypad Replacement Kit

Print System Service Kits

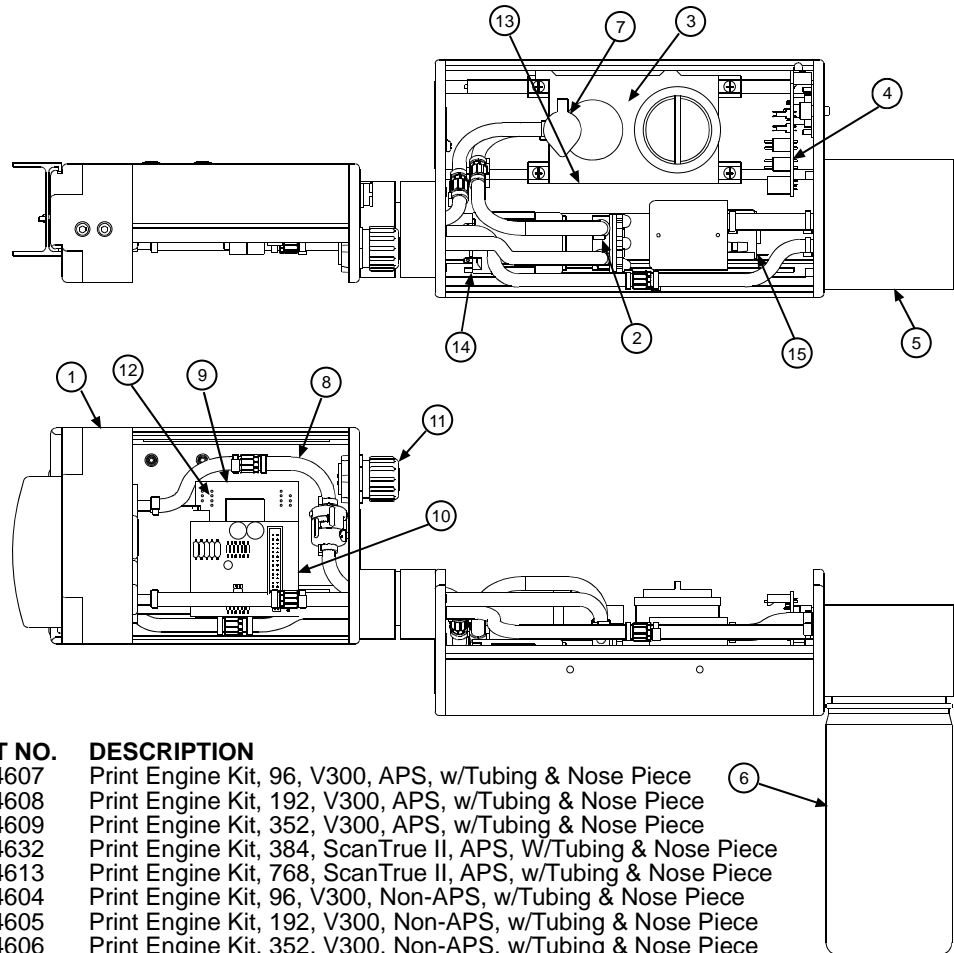

ITEM NO.	PART NO.	DESCRIPTION
1	2464607	Print Engine Kit, 96, V300, APS, w/Tubing & Nose Piece
	2464608	Print Engine Kit, 192, V300, APS, w/Tubing & Nose Piece
	2464609	Print Engine Kit, 352, V300, APS, w/Tubing & Nose Piece
	2464632	Print Engine Kit, 384, ScanTrue II, APS, W/Tubing & Nose Piece
	2464613	Print Engine Kit, 768, ScanTrue II, APS, w/Tubing & Nose Piece
	2464604	Print Engine Kit, 96, V300, Non-APS, w/Tubing & Nose Piece
	2464605	Print Engine Kit, 192, V300, Non-APS, w/Tubing & Nose Piece
	2464606	Print Engine Kit, 352, V300, Non-APS, w/Tubing & Nose Piece
	2464636	Print Engine Replacement Kit, AlphaCoder, ScanTrue II
	2464642	Print Engine Replacement Kit, AlphaMark
2	2464614	Prime Pump Replacement Kit, V300
	2464625	Prime Pump Replacement Kit, ScanTrue II
3 & 8	2464615	Reservoir & Ink Line Tubing Replacement Kit, V300
	2464616	Reservoir & Ink Line Tubing Replacement Kit, ScanTrue II
	2464641	Reservoir & Tubing Replacement Kit, AlphaMark
4	2464617	APS PCB Replacement Kit
5	2464618	Ink Seperator Replacement Kit
6	2464619	Ink Waste Bottle Kit, V300 Ink (APS Only)
	2464620	Ink Waste Bottle Kit, ScanTrue II Ink
7	2464621	Vent Filter Replacement Kit
9	2464623	Marksman Driver Board Replacement Kit
10	2464624	Universal Driver Board Replacement Kit
11	2464120	Communications Cable
12	2464144	Cable, Driver Board to APS PCB
13	5760527	Cable, Reservoir to APS PCB
14	2464146	Cable, Prime Pump to APS PCB
15	2464147	Cable, Vacuum Pump to APS PCB
16	2464629	HV PCB Replacement Kit, 384 and 768 Heads only (Not shown)

NOTE: Please refer to the ProSeries NP192 Manual (2466401) for Service and Parts Kits for the NP192 Integrated Print Head.

Appendix D: Testing the Electrical Outlet



CAUTION: The outlet must be installed near the equipment and must be easily accessible.

ATTENTION: On doit installer à côté de l'appareil une prise de courant facilement accessible.

Before installing the system, verify the integrity of the 115VAC (US and Canada only) sourced power, in accordance with the National Electric Code (NEC) (US only) and approved local electrical codes. If using a standard AC outlet, use the following procedure to verify the integrity of your outlet.

1. Place an outlet tester into the socket. (You can purchase an outlet tester at most hardware stores).
2. If the outlet tester indicates that the outlet is wired correctly, proceed with the installation.
3. If the outlet tester indicates that the outlet is wired incorrectly, inform plant maintenance immediately and do not use the outlet until it has been re-wired.

Electrical Line Transients

Transients on the incoming AC power line can be in the form of voltage spikes and transients, over- and under-voltage events, or noise caused by poor grounding or interference. Symptoms of power related problems can be unexplained loss of controller memory (loss of message), garbled print, and unexplained hardware resets.

The best way to eliminate these types of problems is to install the controller on a dedicated line with a line conditioner. A dedicated line refers to an AC line that only the system components are plugged in to. This is most effective when the source is at the building main service entrance.

Good quality line conditioners will provide protection against all AC line problems with the exception of power outages; if power outages are a problem at the installation, an uninterruptible power supply (UPS) should be installed.



CAUTION: Not for use in a computer room as defined in the Standard for the Protection of Electronic Computer/Data Processing Equipment, ANSI/NFPA 75 (US and Canada only).

ATTENTION: Ne peut être utilisé dans une salle d'ordinateurs telle que définie dans la norme ANSI/NFPA 75 Standard for Protection of Electronic Computer/Data Processing Equipment.

Appendix E: Setting the IP Address

Setting the IP Address on the PC

This section has instructions for setting the IP address and subnet mask of the PC so it can communicate with the Marksman© Pro Controller. Included are instructions for Windows XP®, Windows 2000®, Windows 98®, and Windows 95®.

Windows XP®

1. Open the **Start** menu; select **Settings**, then **Network Connections**.

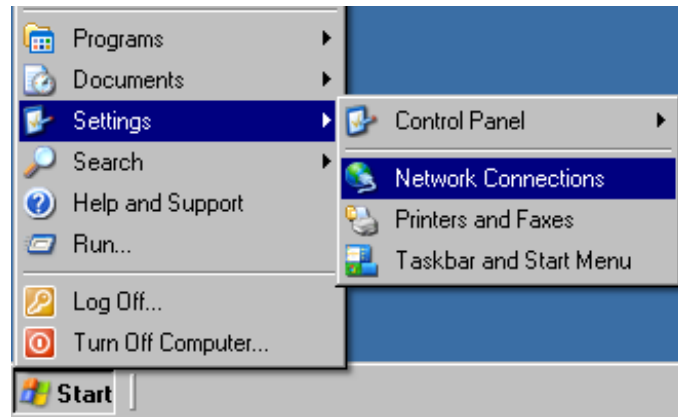

2. Click **Local Area Connection**, then open the **File** menu and select **Properties**.

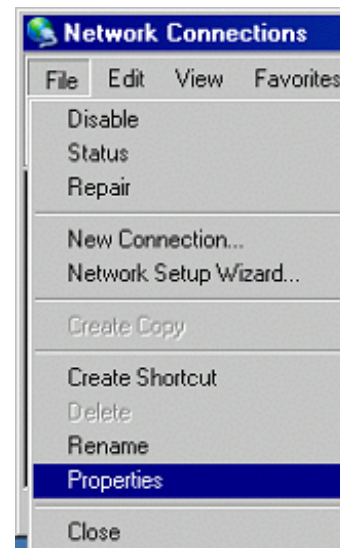
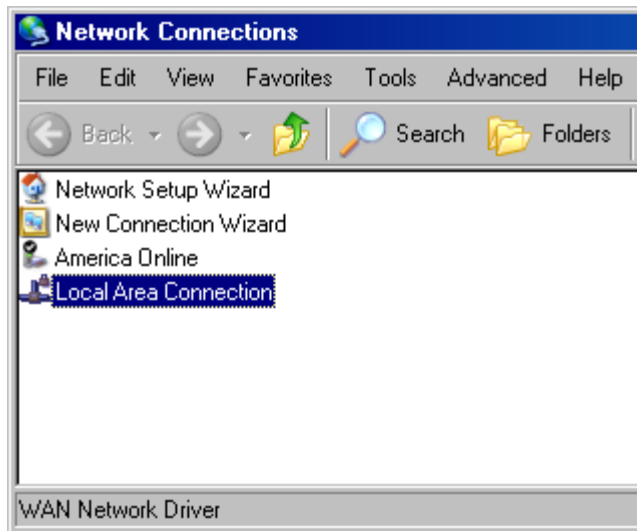

3. Select **Internet Protocol (TCP/IP)** then click the **Properties** button.

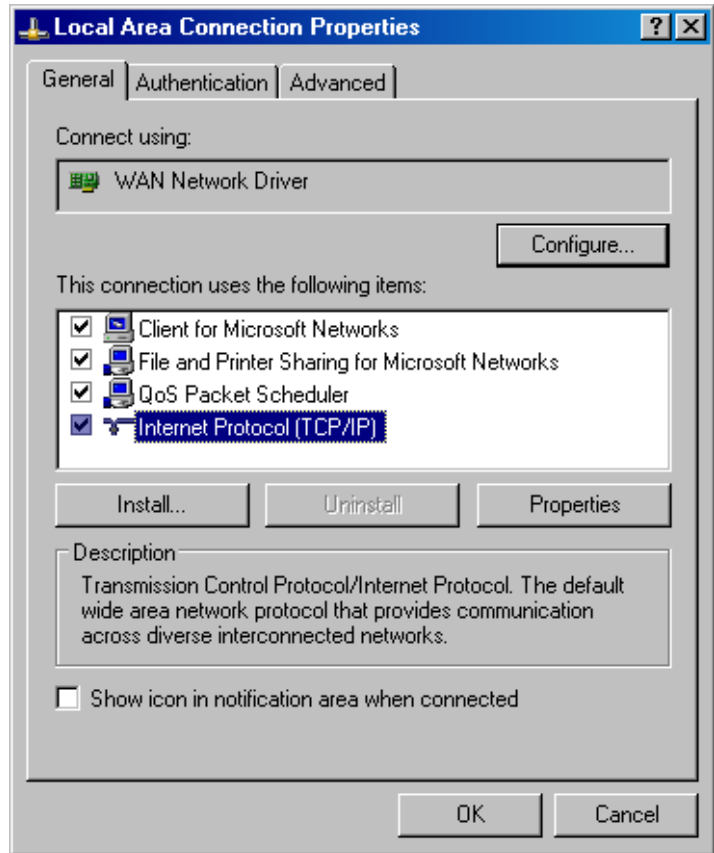

4. Click the **Use the following IP address** radio button. Enter an IP address of 10.1.2.4, a subnet mask of 255.255.255.0, and click the **OK** button.

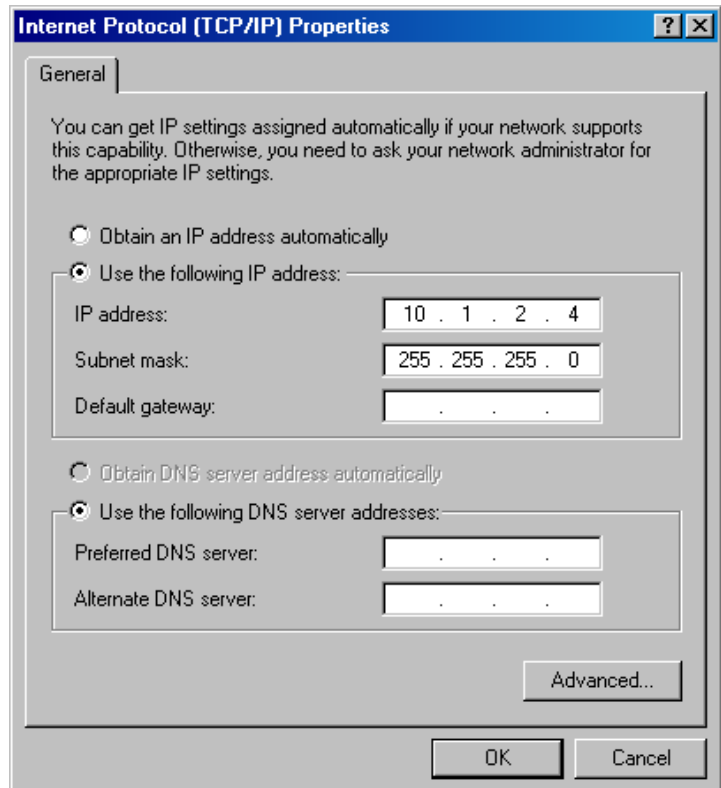

Windows 2000®

1. Open the **Start** menu; select **Settings**, then **Network and Dial-up Connections**.

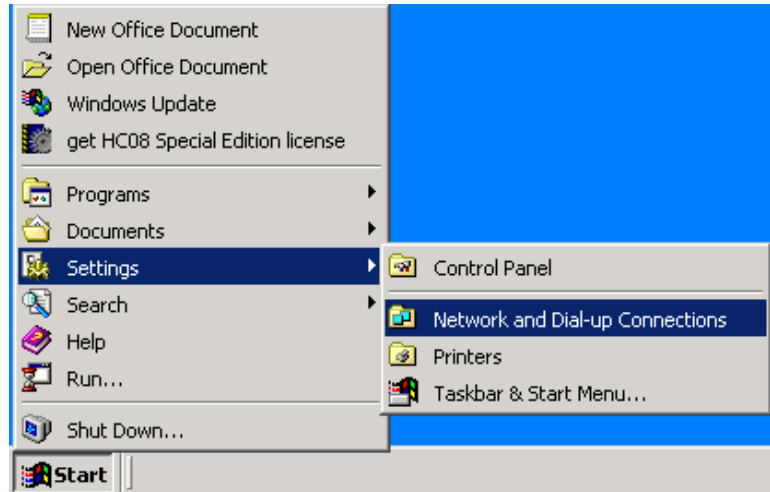

2. Click the desired connection, then open the **File** menu and select **Properties**.

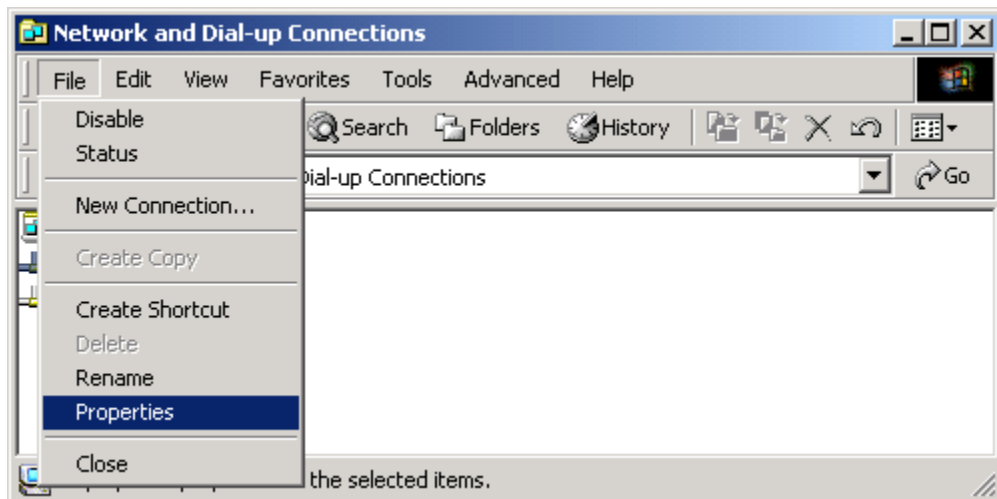
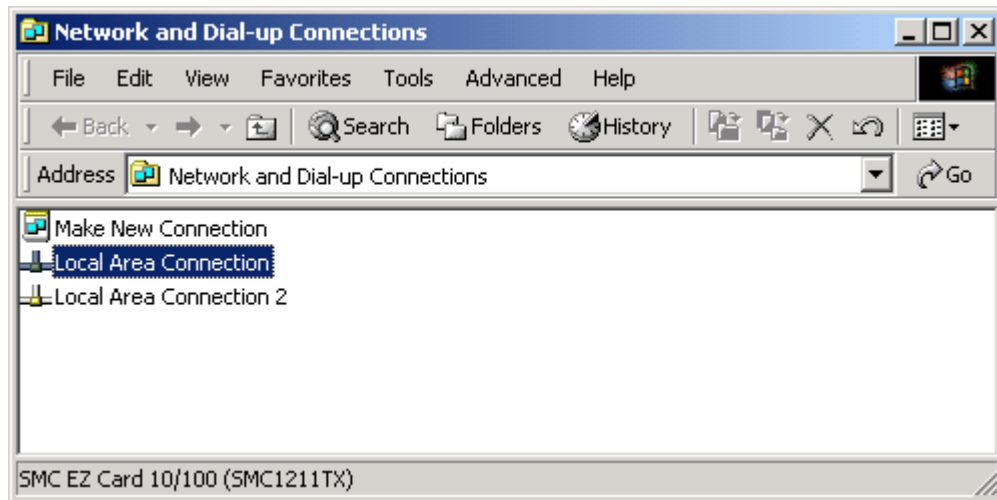

3. Select **Internet Protocol (TCP/IP)** then click the **Properties** button.

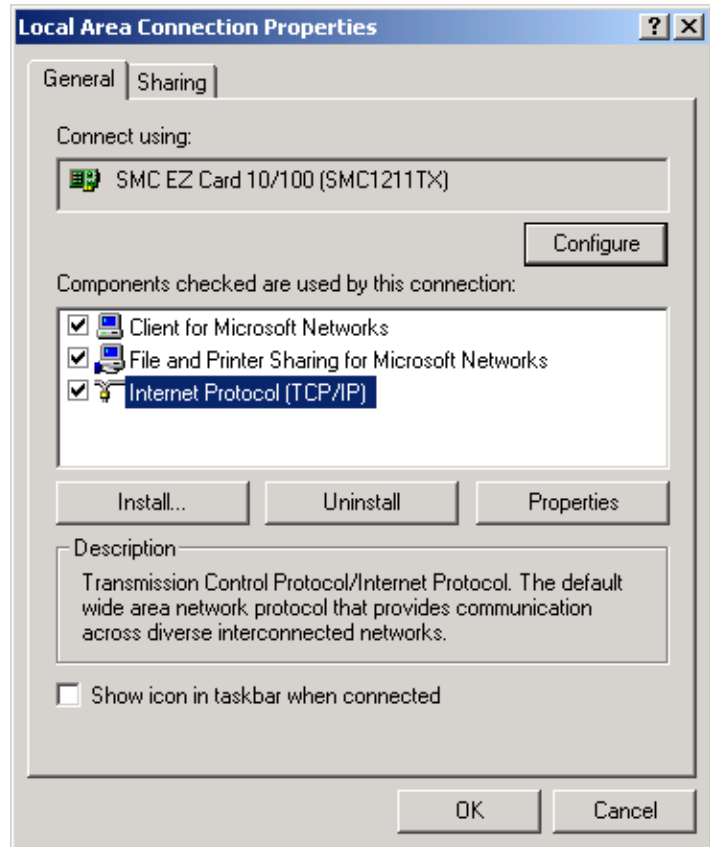

4. Click the **Use the following IP address** radio button. Enter an IP address of 10.1.2.4, a subnet mask of 255.255.255.0, and click the **OK** button.

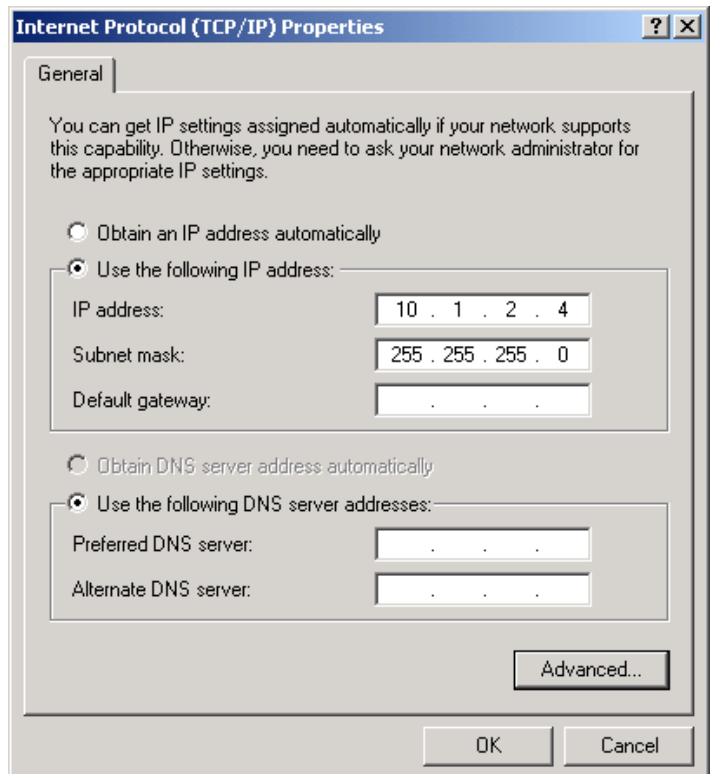

Windows 98®

1. Open the **Start** menu; select **Settings**, then **Control Panel**.



2. Double-click the **Network** icon (bottom row, second from the right in the illustration below.)



3. Select **TCP/IP** and click the **Properties** button.

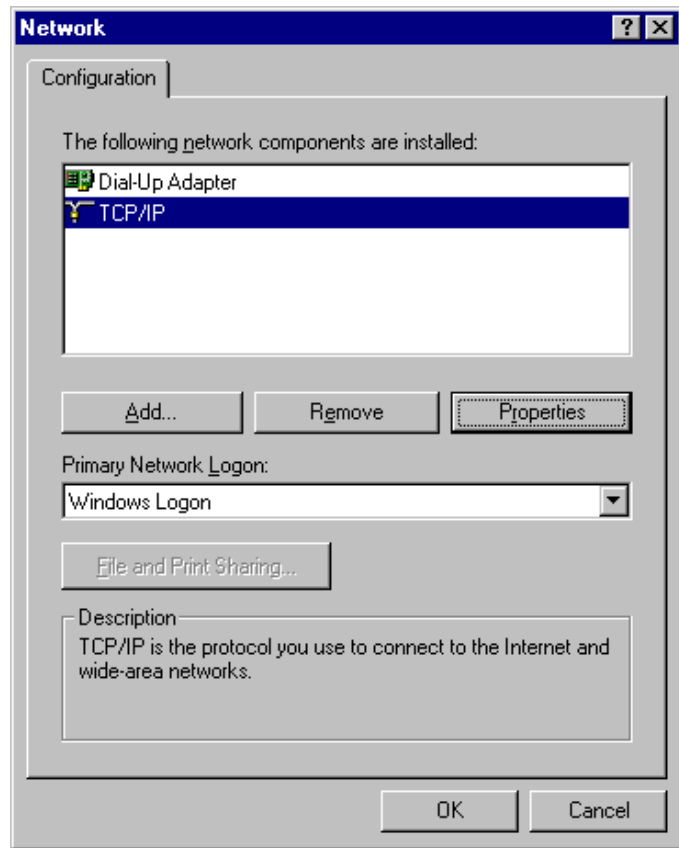

4. On the **IP Address** page, click the **Specify an IP address** radio button. Enter an IP address of 10.1.2.4, a subnet mask of 255.255.255.0, and click the **OK** button.

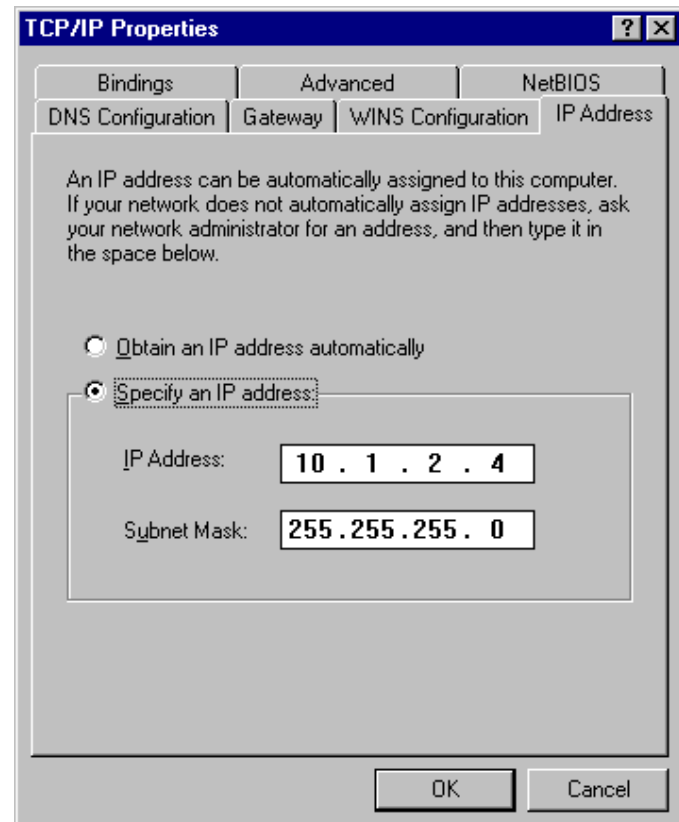

Appendix F: Database Start

Description

Prior versions of BoxWriter allowed for the start of a task with database elements, which can then prompt the user to enter the key field value for the Pro to search the database and replace the default database element data with the data from the remote data source. In addition to those features, this version allows the Pro to prompt for the key field value, obtain that value, look up that value in the database (which is preconfigured for all messages in the Pro), find the task field in the database, use that value to start the corresponding task, and while starting the task, use the previously entered key field value as the value for all fields in the database. Thus, the user needs only to enter one value to start the correct task **and** all data in the task. This is referred to as Database Start.

Database Start Task Routine Flowchart

The following flowchart briefly explains the new process:

1. The Operator initiates a database task start routine. This can be accomplished by using the **Operate, Database Start** menu option. In addition, the operator may use the new "**play**" button on the toolbar indicated by the yellow cylinder. Finally, a new serial option called **Database Task Start** is available for use with hand scanners and/or remote systems.
2. The system will respond by prompting the user for a key field value.
3. Based on the user's input, the software goes to the predefined record source to locate the key field based on the value from step #2.
4. Once located, the software pulls up that record's information. Based on the predefined field for a task name, the system looks at that field for the task name to start.
5. The software then starts that task and any database elements that are tied to the same record (as in step #4); the system does **not** prompt the user, but instead uses the data out of that record automatically. The system is now ready to print, unless there are additional user-prompted fields necessary (see step #6).
6. If any other user-prompted information is necessary (such as database elements that specify a different record set or standard user-prompted elements), the system will prompt for these elements.

Database Lookup Definition - Global Setting

In order for the Marksman Pro to go to an outside database for task name information, it is necessary to first globally define where that location will reside. To instruct the Marksman Pro where this data will reside, the details must be entered on the new menu option **Configure, Database**.

First, click the **Select** button to select the DSN entry to use when utilizing the database start routine.

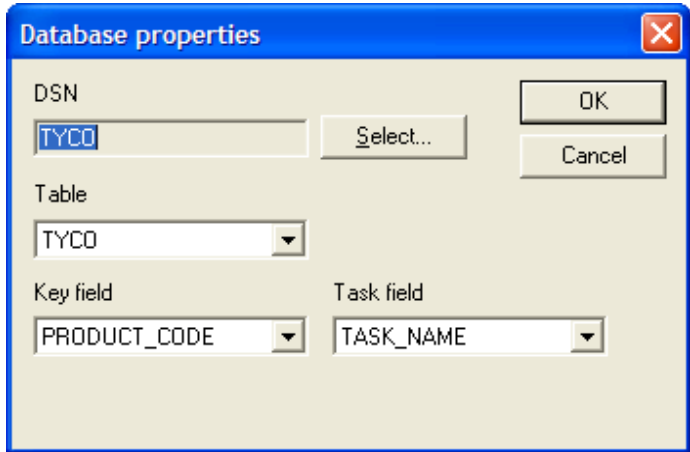

Each of the available tables (or sheets) will be available based on the DSN entry. Select the appropriate table for use.

Next, choose the field that will be utilized for the Key field - to identify the record in which the task name will be found.

Finally, choose the field where the task name is located.

A sample table is shown below for reference (based on input above).

TYCO Sample Table (This "TYCO" table is contained in an Access Database named TYCO in a DNS named TYCO):

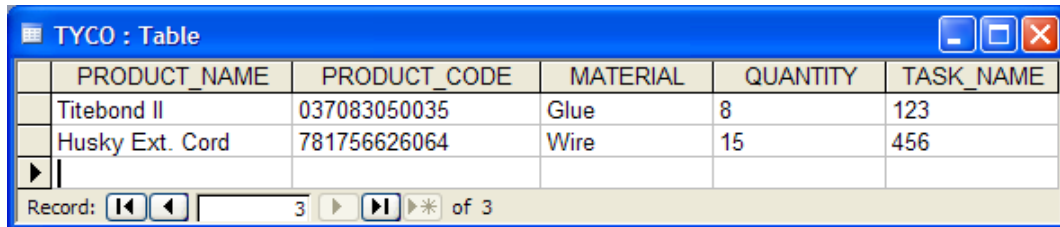

PRODUCT_NAME	PRODUCT_CODE	MATERIAL	QUANTITY	TASK_NAME
Titebond II	037083050035	Glue	8	123
Husky Ext. Cord	781756626064	Wire	15	456

Database Start Task

By accessing either the menu option **Operate, Database Start** or by using the newly available toolbar button (just to the right of the normal task start button), the operator is presented with the database start task screen.

The operator can either input the key field by using the keyboard or clicking the select button to choose from the database view.

Clicking **OK** starts the Database Start Routine flowchart as indicated previously in this section.

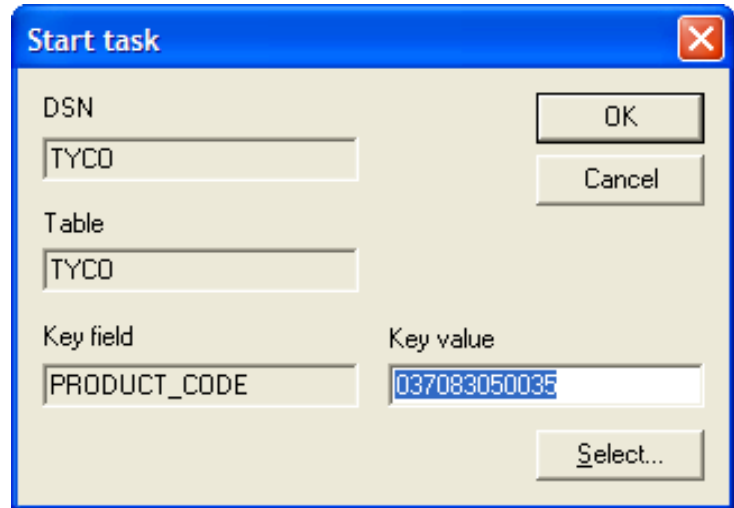

Serial Port Modification

In addition to accessing the new menu option and toolbar button, the serial port options have been modified to allow for a "Database task start" as seen in the figure at right.

When set to the database task start setting, the system will accept serial input from the communication port and use this information as the key field value, as indicated in the Start task screen in the previous figure.

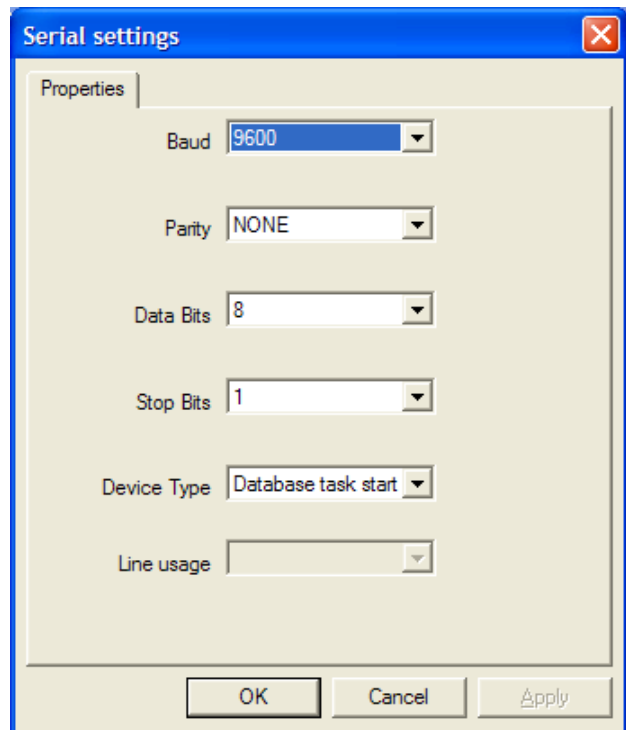

Printer Report Modification

In order to determine what key field has been selected by the operator, the printer report has been modified to indicate the chosen key field. The key field will be indicated on the preceding line under the Task Name field.

A screenshot of a 'Print Report' window. The window has a blue title bar with the text 'Print Report' and a close button (red X) on the right. Below the title bar is a table with the following data:

Time	Action	User	Line	Task name	Co...
11/05/07 17:03:28	Database start - key value	ROOT	LINE0001	456: 781756626064	
11/05/07 17:03:28	Start task	ROOT	LINE0001	456	29
11/05/07 17:03:34	Stop task	ROOT	LINE0001	456	35

Appendix G: Hand Scanner

Scan and Shoot Setup

The first step in setting up the hand scanner is determining which numbers in the barcode are to be used to select the task to be started. The following example will demonstrate the process by using 5 digits of a 12 digit UPC barcode. You will need to print this page if you plan on using the example barcode. It may be preferable to get an actual barcode that will be used.

Create a task

The task that is to be printed after the barcode is scanned must be associated with that barcode. This is done by creating a task and giving it the name of the 5 digits of the barcode being used to start the task. In the example below, the barcode being scanned is:

0 79068 17001 7

The part of the barcode that will be used to identify the task is highlighted: **17001**. This is the name that will be given to the task. A task should now be created using the name **17001**.



Scanner

Plug the scanner into a serial port, either the *Auxiliary Input port or Com1 port.

Setup the port that was chosen to match the scanner:

*AUXILIARY INPUT:

**Configure/Print heads/Head 1/
More /Define**

Com1:

**Configure/System/General Set-
tings/Com1/Properties**

*** NOTE:** There is +12V on pin 1 of the auxiliary input port that is used to power the Foxjet scanner.

Set up the serial port to match the scanner:

- Baud = 9600
- Party = NONE
- Data Bits = 8
- Stop Bits = 1
- Device Type = Task start
- Line usage = N/A

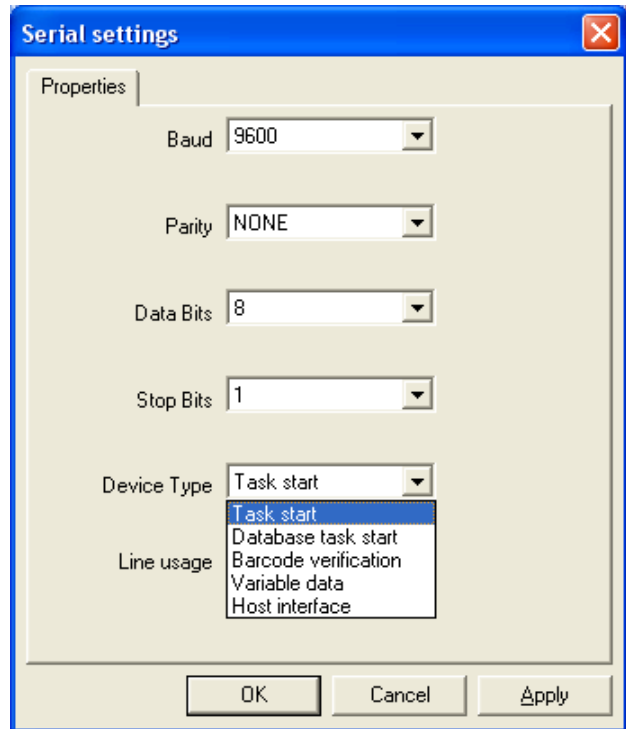

The port is now set up to start a task from a serial string.

Mask task name from a serial string:

To create the mask to separate the task name from the barcode, go to the line properties: **Configure/Production Line**. Edit the line where the head is located.

Buffer offset: The number of characters in the string to the start of the task name, starting with 0. In our example the offset is 6.

Barcode characters: 0 7 9 0 6 8 1
 Buffer Offset Count: 0 1 3 2 4 5 6.

Data length: The number of characters in the task name.

17001= 5 characters

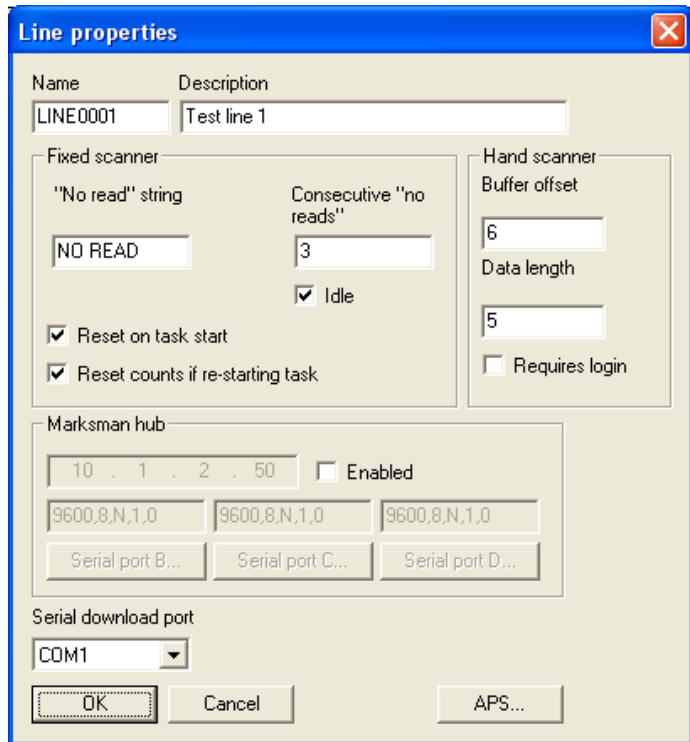

Testing the Start Task

The controller should now be set up to start a task using a hand scanner. Make sure there are no tasks running; use the **Stop** button if a task is selected.

Use the hand scanner and scan the barcode that the task was created from. If the task starts, then the controller is set up. Additional tasks can now be added as needed using the same approach as above.

If the task fails to start:

- Check that the scanner is programmed for a UPC and that it has a carriage return for a postamble.
- Check that the scanner is connected to the proper port and that it is configured correctly.
- If a "Task Failed To Start" message appears, make sure that the task is properly named and that it matches the barcode.

The Diagnostic window (**View/Diagnostic Dialog**) can be used to assist in the troubleshooting process.

Appendix H: Fonts

Font List

In addition to the standard TrueType fonts, the following fonts were designed specifically for the Marksman© Pro. (Contact the Distributor for special fonts, special characters or new fonts.)

- MK Aardvark
- MK Arabia
- MK Arial
- MK Arial Low Caps
- MK Avalon
- MK Barcode
- MK Courier
- MK Courier Low Caps
- MK Diploma
- MK Fujiyama
- MK Gothic
- MK Harquil
- MK Harquil Low Caps
- MK Script
- MK Times
- MK Times Low Caps

Font Samples

The following samples were printed with a ProSeries 768 Print Head at 300 dpi (standard) and default width. The first two sets of Fonts (Aardvark and Arabia) are shown at 128, 64 and 32. The remaining fonts are shown at 64 only, but other sizes are available.

MK Aardvark 128

ABCcab

MK Aardvark 64

ABCabc

MK Aardvark 32

ABCabc

MK Arabia 128

ABCabc

MK Arabia 64

ABCabc

MK Arabia 32

ABCabc

MK Arial 64

ABCabc

MK Arial Low Caps 64

ABC_{ABC}

MK Avalon 64

ABCabc

MK Barcode 64

ABCabc

MK Courier 64

ABCabc

MK Courier Low Caps 64

ABCABC

MK Diploma 64

ABCabc

MK Fujiyama 64

ABCabc

MK Gothic 64

ABCabc

MK Harquil 64

ABCabc

MK Harquil Low Caps 64

ABCABC

MK Script 64

ABCabc

MK Times 64

ABCabc

MK Times Low Caps 64

ABC_{ABC}

Appendix I: Standard Operating Procedures

FJSOP1 - Removal of FoxJet High Resolution Printheads

PURPOSE: To detail the procedure for removing a Foxjet High-Resolution inkjet printhead from a production line.

RESPONSIBILITY: Customer or authorized FoxJet Distributor technician.

SAFETY: All personnel performing this procedure must wear proper eye protection and latex gloves.

FREQUENCY: Each time a printhead is to be removed from a production line.

PROCEDURE:

1. Initiate the proper controller shutdown procedure, TURN OFF AND UNPLUG THE CONTROLLER from electrical power source to avoid possible electrical problems and/or electric shock.
2. Disconnect all printhead cables from the controller.
3. Remove the ink bottle and install the Reservoir Ship Cap.
4. Remove vent cap filter (if applicable) and close the vent cap.
5. For an AMS/APS system, remove Waste Ink Bottle and reinstall the Short Black Protective Shipping Bottle.
6. Install the faceplate cover on the front of the printhead (when properly installed it should cover the CP/OP).



7. Insure that all printhead covers are properly installed, clean and all screws are in place.

8. Remove all photocell and photocell brackets from the printhead, if applicable.
9. Remove screws that hold the printhead to the bracketry.
10. Wrap a clean shop cloth around the front of the printhead to catch any ink that may leak out and secure the cloth with masking or packing tape.
11. Place a plastic bag over the printhead assembly and secure it with tape.

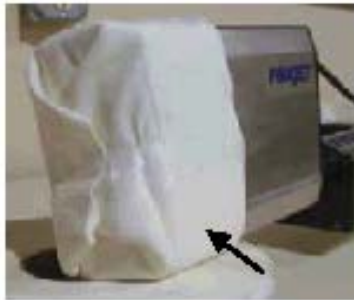

12. If the printhead is to be stored for later use, it should be stored in a cool, dry location.
13. If the printhead is to be shipped, it should be well padded and packed in its original shipping box.



CAUTION:

Observance and practice of this procedure is critical to insure no damage occurs during shipping.

FoxJet will replace, and charge for, any items found to be missing before it can be returned.

FoxJet may deny warranty coverage if the printer or part has failed as a result of abuse, neglect, improper maintenance, improper shipping, or unapproved modification(s). Please refer to the Master Warranty Statement.

END

FJSOP2 - Daily Maintenance for AMS/APS Printheads

- SCOPE:** All AMS/APS (Automatic Priming System) Printheads.
- PURPOSE:** Detail the procedure for performing the required maintenance routine for Foxjet AMS/APS High-Resolution inkjet printheads.
- RESPONSIBILITY:** Customer.
- SAFETY:** All personnel performing this procedure must wear proper eye protection and latex gloves.
- FREQUENCY:** This procedure is to be performed daily, or as often as required, depending on print quality.

PROCEDURE:

1. Using a lint-free Texwipe, carefully clean any corrugated dust, hot melt glue strings and/or other debris from the CP/OP area. Be sure to wipe across the CP/OP in one direction, NOT UP AND DOWN OR BACK AND FORTH, to lessen the likelihood of debris being pushed into the orifices. Failure to wipe in the appropriate direction will damage the CP/OP.
 2. Press and release the purge button to initiate an automatic prime/purge cycle (observe that the ink is vacuumed off the CP/OP).
 3. Wipe across the CP/OP with a lint-free Texwipe in one direction to remove excess ink, if necessary.
 4. Verify that all screws are in place and that covers are clean and properly installed.
 5. Insure that the front of the printhead is parallel to, and within 6mm (0.25") or less, of the side of the carton as it passes in front of the printhead.
 6. Insure that the conveyor guides are adjusted to prevent cartons from contacting the printhead.
 7. Run a print sample to ensure all the channels are printing and producing good print quality.
- IF PRINT QUALITY IS ACCEPTABLE, PROCEED NO FURTHER.
8. If there are several channels not printing, take several lint-free Texwipes and press them against the front of the CP/OP to catch the ink during the next step in the maintenance process.
 9. Press and hold the purge button for three to four seconds to prime the system or purge air from the printhead.

10. Spray the proper maintenance fluid, as identified below, on a dry wipe card or folded Texwipe.
 - 10.1 For Printheads using VersaPrint ink, use FoxJet P/N X31003-001 spray.
 - 10.2 For Printheads using ScanTrue II ink, use FoxJet P/N X31027-001 spray.
11. Wipe across the CP/OP with the wipe card or lint-free Texwipe to remove any excess ink and/or maintenance spray.
12. Run a print sample to ensure all the channels are printing and producing good print quality.

IF PRINT QUALITY IS ACCEPTABLE, PROCEED NO FURTHER.

13. If there are any channels that still do not print, repeat steps 8 through 12 as required.

Replacing APS waste ink bottles

FoxJet APS systems have waste ink catch bottles installed to the rear of the printhead/ink system and employ a waste ink detection circuit to disengage the APS feature when the bottle becomes full. Failure to replace a full waste ink bottle will disengage the APS system.

To maximize equipment longevity and increase performance, preventive maintenance routines must be performed on pre-defined daily, weekly, and/or monthly schedules.

If performing these measures is not already a regular practice, it should be immediately established as a top priority to prolong the life of the system.

FoxJet may deny warranty coverage if the printer or part has failed as a result of abuse, neglect, improper maintenance, or unapproved modification(s). Please refer to the Master Warranty Statement.

END

FJSOP3 - Daily Maintenance for non-AMS/APS Print-heads

SCOPE: All non-AMS/APS (Automatic Priming System) Printheads.

PURPOSE: Detail the procedure for performing the required maintenance routine for Foxjet non-AMS/APS High-Resolution inkjet print-heads.

RESPONSIBILITY: Customer.

SAFETY: All personnel performing this procedure must wear proper eye protection and latex gloves.

FREQUENCY: This procedure is to be performed daily, or as often as required, depending on print quality.

PROCEDURE:

1. Using a lint-free Texwipe, carefully clean any corrugated dust, hot melt glue strings and/or other debris from the CP/OP area. Be sure to wipe across the CP/OP in one direction, NOT UP AND DOWN OR BACK AND FORTH, to lessen the likelihood of debris being pushed onto the orifices. Failure to wipe in the appropriate direction will damage the CP/OP.
2. Fold 2 Texwipes over and hold them against the face of the printhead to catch the ink during the next step in the maintenance process.
3. Press and hold the priming button for three to four seconds to prime the system or purge air from the printhead.

There are two types of Non AMS/APS Heads on the Market:

A: With a motorized priming pump and button to energize it.

B: With a prime bulb mounted to the rear of the Print Head Assembly. With this type printhead, only push the bulb in. Do not squeeze or pinch the bulb, which can damage the bulb and/or the valve internal to it.

4. Wipe across the CP/OP in one direction with a lint-free Texwipe to remove excess ink.
5. Verify that all screws are in place and that printhead covers are clean and properly installed.
6. Insure that the front of the printhead is parallel to, and within 6mm (0.25") or less, of the side of the carton as it passes in front of the printhead.
7. Insure that the conveyor guides are adjusted to prevent cartons from contacting the printhead.

8. Run a print sample to ensure all the channels are printing and producing good print quality.

IF PRINT QUALITY IS ACCEPTABLE, PROCEED NO FURTHER.

9. If there are several channels not printing, fold two Texwipes over and hold them against the face of the printhead to catch the ink during the next step in the maintenance process.

10. Press and hold the priming button for a maximum of five seconds to prime the system or purge air from the printhead.

11. Spray the proper maintenance fluid, as identified below, on a dry wipe card or folded Texwipe.

11.1. For Printheads using VersaPrint ink, use FoxJet P/N X31003-001 spray.

11.2. For Printheads using ScanTrue II ink, use FoxJet P/N X31027-001 spray.

11.3. For Printheads using AlphaMark ink, use Ethyl Alcohol (commercially available).

12. Wipe across the CP/OP with the wipe card or folded Texwipe to remove any excess ink and/or maintenance spray.

13. Run a print sample to ensure all the channels are printing and producing good print quality.

IF PRINT QUALITY IS ACCEPTABLE, PROCEED NO FURTHER.

14. If there are any channels that still do not print, repeat steps 8 through 12 as required.

Maintenance Requirements

To maximize equipment longevity and increase performance, preventive maintenance routines must be performed on pre-defined daily, weekly, and/or monthly schedules.

If performing these measures is not already a regular practice, it should be immediately established as a top priority to prolong the life of the system.

FoxJet may deny warranty coverage if the printer or part has failed as a result of abuse, neglect, improper maintenance, or unapproved modification(s). Please refer to the Master Warranty Statement.

END

FJSOP4 - Installation of FoxJet High Resolution AMS/APS Printheads

PURPOSE: Detail the procedure for installing a FoxJet AMS/APS high-resolution inkjet printhead onto the production line.

RESPONSIBILITY: Customer or Distributor.

SAFETY: All personnel performing this procedure must wear proper eye protection and latex gloves.

FREQUENCY: Every time a printhead is installed on the production line.

PROCEDURE:

1. Remove packing materials and retain for possible future use.
2. Insure that all printhead covers are properly installed, clean and all screws are in place and tight.
3. Position the printhead and install the screws that hold the printhead to the printhead bracketry.
4. Adjust bracketry so that the front of the printhead is parallel to, and no more than 6mm (0.25") away from, the side of the carton as it passes in front of the printhead.
5. Insure that conveyor guides are adjusted so that the cartons CANNOT hit the printhead.
6. Remove the Reservoir ship cap and install the ink bottle (insure the expiration date on the ink bottle has not yet occurred).
7. Open the vent cap and install a clean vent cap filter (FoxJet PN X40119-001).
8. If not installed, install an ink waste bottle (FoxJet PN X01240-002).
9. Remove the faceplate cover from the front of the printhead (Save the faceplate cover and Reservoir ship cap for use when you remove the printhead from the production line).
10. Switch controller power OFF.
11. Unplug controller from power source, if applicable.
12. Connect the printhead cable to the controller.
13. Connect the photocell cable to the printhead, if applicable.
14. Plug the system into a dedicated source of clean electric power.
15. Turn the power on to the printhead and wait for it to heat to temperature, which should take approximately five to ten minutes. (A Marksman Net or UJII 352/32 Printhead may take up to 30 minutes. On Marksman Net and Marksman Pro Series controllers, it may take approximately 30 minutes to bring a ProSeries printhead to the appropriate temperature.)

16. Take several lint-free Texwipes and press them against the front of the CP/OP to catch any ink.
17. Press the purge switch for three to four seconds to purge any air out of the system.
18. Spray the proper maintenance fluid, as identified below, on a dry wipe card or folded Texwipe.
 - 18.1 For Printheads using VersaPrint ink, use FoxJet P/N X31003-001 spray.
 - 18.2 For Printheads using ScanTrue II ink, use FoxJet P/N X31027-001 spray.
19. Momentarily press the purge switch to initiate an automatic prime/purge cycle.
20. Wipe across the CP/OP with the wipe card or lint-free Texwipe to remove any excess ink and/or maintenance spray.
21. Run a print sample to ensure all the channels are printing and producing good print quality.

IF PRINT QUALITY IS ACCEPTABLE, PROCEED NO FURTHER.
22. If all channels are not printing properly, repeat steps 16 through 21. If the printhead has not been in use for several months, it may take 30+ minutes for all channels to print.

END