Ink Jet Printer Operations Manual

5750-440
Revision F

English

Prompts in some languages do not fit inside the twenty-character lines of the liquid crystal display. When a prompt extends beyond twenty characters, the full text of the prompt appears in this book. Always check this book when you are uncertain about the meaning of a prompt on the display.

Not for use in a computer room as defined in the Standard for the Protection of Electronic Computer/Data Processing Equipment, ANSI/NFPA 75.

Ne peut être utilisé dans une salle d'ordinateurs telle que définie dans la norme ANSI/NFPA 75 Standard for Protection of Electronic Computer/Data Processing Equipment

The information contained in this manual is correct and accurate at the time of its publication. Illinois Tool Works reserves the right to change or alter any information or technical specifications at any time and without notice.

© 2006 Illinois Tool Works Inc
All rights reserved.
Printed in the United States of America

Table of Contents

Warranty & Introduction		Placing Variables in Messages	E
SAFETY	i	Placing the Date in a Message	E1
Ink Jet Printer Features.....	ii	Placing the Expiration Date in a Message	E2
Controller	iii	Placing the Time in a Message.....	E3
Basics	A	Placing a Work Shift in a Message.....	E4
Printing a Message.....	A1	Placing an Item Count in a Message.....	E5
Creating a Simple Message	A2	Placing a Pallet Count in a Message.....	E6
Editing a Message	A3	Using Alternate Characters	E7
Deleting a Message	A4	System Operation	F
Viewing System Information	A5	Selecting a Language.....	F1
Frequently Asked Questions.....	A6	Setting the Date	F2
Maintenance	B	Setting Units of Measure.....	F3
Loading Ink	B1	Setting the Print Mode.....	F4
Purging All Channels	B2	Setting the Message Gap	F5
Purging a Single Channel	B3	Setting the Box Length	F6
Purging With Conditioner	B4	Setting the Print Speed	F7
Broaching the Orifice	B5	Setting the Print Direction	F8
Startups & Shutdowns	B6	Using a Password.....	F9
Changing Ink Colors	B7	Using the External Photocell Model.....	F10
Adjusting the Screen Contrast.....	B8	Sample Messages	G
Resetting Factory Defaults	B9	New Message	G1
Print Adjustments	C	Message with Date and Count	G2
Changing an Individual Message Indent	C1	Message with Expiration Date	G3
Setting the Default Message Indent.....	C2	Message with Alternate Characters	G4
Changing Character Width in a Message.....	C3	Wide Message with Time Mark	G5
Setting the Default Character Width	C4	Message with Pallet and Item Count.....	G6
Changing the Printed Dot Size	C5	Troubleshooting	H
Changing the Font in a Single Message.....	C6	Not Printing	H1
Changing the Default Font.....	C7	Unsatisfactory Print.....	H2
Rotating the Message	C8	Printhead Leaking.....	H3
Adjusting a Single Dot Diameter	C9	Printhead Preload Adjustment	H4
First Dot Adjustment	C10	Ink Regulator Maintenance Procedure	H5
Sizing Dots in Columns	C11	System Specifications	App A
Setting Message Variables	D	Controller/Ink Delivery System.....	A1
Setting the Date	D1	Printhead	A2
Setting an Expiration Date.....	D2	Parts and Supplies	App B
Setting the Time	D3	Service Parts Kits	B1
Setting Work Shifts	D4	Consumables	B2
Setting the Shift Start (Code Date).....	D5	Assembly Drawings.....	B3
Setting the Item Count	D6	Theory of Operation	App C
Setting a Pallet Count	D7	Mechanical	C1
		Electrical.....	C2

Warranty

The Ink Jet System (excluding printhead) carries a 365 day limited warranty from the date of shipment. The Printhead carries a 180 day limited warranty from the date of shipment. For all terms and conditions, refer to the full warranty statement packaged with the Ink Jet Printer.

Use of the wrong fluid type in the system is not covered under warranty.

Introduction

NOTE: This manual describes operation of both the porous (water-based) and non-porous (alcohol-based) printers. Water-based fluids can **NOT** be used in non-porous (alcohol-based) systems. Alcohol-based fluids can **NOT** be used in porous (water-based) systems.

The ink jet printing system is compact and easy to use. It prints a single line of alphanumerics at speeds as slow as 5 fpm and as fast as 250 fpm. Print quality is excellent and it offers message control and printhead flexibility. There are three font choices: 5-dot (3/8"), 7-dot (1/2") and 7-dot bold and it can print with multiple fonts on the same line. The ink is contained in a 13 fluid ounce (392 ml) pressurized canister. Ink canisters can be replaced without interrupting production. You can choose from six high-visibility ink colors: black, blue, green yellow, orange and red.

The printhead has patented I.V. (Integrated Valve) print technology and individual dot control capability, resulting in better print quality. Ink does not touch the internal electronics of the printhead, ensuring long-term operational reliability. It has flexible mounting that allows printing on the side, top or bottom of cartons as well as printing on inclined surfaces. There are two built-in photosensors that measure speed and direction and are located in the face of the printhead. The printhead requires daily maintenance measures (purging) performed at the beginning of the work day, and following an extended shutdown of a week or more.

The controller offers a QWERTY keypad with ALT key for multiple key combinations, separate number keys, icon function keys, four keys for cursor control and four LEDs (that warn or show status of power, photosensor, print mode and low ink). It has autocode capabilities that allow for Julian/Gregorian date, time sequential numbering, shift, item count, pallet/batch count and expiration date. It also has message storage capabilities of 99 fifty-character messages and an "ink out" alarm. Tubing comes attached to the controller and connects to the back of the printhead. A power supply unit connects to the controller and sets in a holster on the mounting bracket.

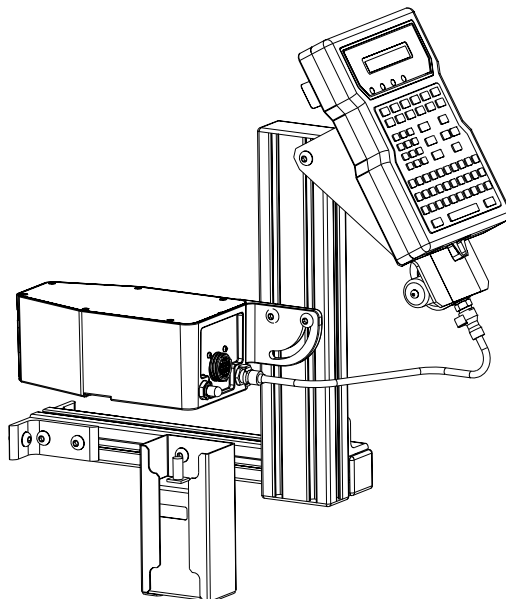

SAFETY

i

Following is a list of safety symbols and their meanings, which are found throughout this manual. Pay attention to these symbols where they appear in the manual.



Wear safety goggles when performing the procedure described!



Caution! Denotes possible personal injury and/or damage to the equipment.



Caution! Denotes possible personal injury and/or equipment damage due to electrical hazard.



NOTE: (Will be followed by a brief comment or explanation.)



CAUTION: Turn off the equipment's main power before:

- Performing preventive maintenance.
- Performing any repairs to the unit.
- Servicing the equipment in any manner.

ESD (Electro-Static Discharge) protection should be worn when servicing internal printed circuit boards.

After service to the equipment is completed, replace all protective devices such as grounding cables and covers before operating the equipment.



It is extremely important to:

- Refer to your supervisor for complete instructions on personal protective equipment (PPE) required to work safely with this system.
- Read the MSDS (Material Safety Data Sheet) and follow its instructions for proper storage, handling and disposal of inks and conditioners.



PRODUCT COMPLIANCE DISCLAIMER NOTE:

This product meets the requirements of CAN/CSA-22.2 NO.60950-00 * UL 60950 using ITW Company approved items. Units are only tested and qualified with ITW Company approved inks, parts and accessories. Use of other inks, parts or accessories may introduce potential risks for which ITW can assume no liability.

Ink Jet Printer Features

The Ink Jet Printer has a variety of features that make it uniquely suited to print in industrial printing applications.

- Self-contained printing system for marking products moving on conveyors.
- Adjustable printhead that allows for side, top, or inclined conveyor printing at line speeds up to 250 feet (76 meters) per minute.
- Prints characters up to seven dots high, one half-inch tall.
- Ink supply system from a pressurized can. Cans can be changed during operation for uninterrupted printing.
- Detects product direction and speed of movement with photosensors mounted in the front of printhead. An external photosensor option is available.
- Prints one message per item or many messages per item.
- Twelve function keys for easier editing and system operation.
- Built-in count, shift, time and date codes including expiration dates.
- Prints in three different fonts: 3/8 inch (9.5 mm), 1/2 inch (12.7 mm) and 1/2 inch (12.7 mm) bold.
- Screen menus in multiple languages.
- Two-line, twenty character per line, liquid crystal display.
- Power supply operates on 100 to 240 VAC input.
- May be used between 40° F (4.4° C) and 110° F (43.4° C).
- Modular printhead design that incorporates Quick Disconnects for easy maintenance.
- Modular spare parts kits for easy maintenance.
- Long printhead bracket for easy printing on top of a product.
- Ink and electronics are separated throughout the system to ensure reliability and industrial durability.
- Ink available in several colors: Black, Blue, Green, Red, Orange and Yellow.
- Supplies available worldwide.

Controller

DISPLAY

- Two-line, twenty character per line, liquid crystal display (LCD).

LEDs

- Power LED; lit when the printer has power.
- Photo-eye LED; on while a product passes by.
- Print LED; lit when the printer is in print mode.
- Ink out LED; blinks when the ink can is out of ink.

FUNCTION KEYS

- PRINT: Starts and stops printing.
- EDIT: Create, edit or delete a message.
- PURGE: Purge all ink channels; with ALT (24), it purges single channels.
- MESSAGE INDENT: Sets the message indentation from the leading edge of the product.
- FONT: Selects the font to print.
- TIME: Inserts the printed time into a message. With ALT (24), it inserts a work shift code..
- SET-UP: For configuration of the system.
- INFORMATION: Provides status and setting information.
- DOT SIZE: Increases or decreases all dot sizes at once.
- CHARACTER WIDTH: Changes the width of printed characters which produces changes in the length of printed messages.
- DATE: Inserts the date into a message. With ALT (24), it inserts an expiration date.
- ITEM COUNT: In print mode, it shows the last count for Item, Pallet and Total; in edit mode, it inserts the item count into a message. With ALT (24), it inserts a pallet count.

NUMERIC KEYPAD

- Keys for number entry which will show alternate characters when scrolled with the arrow keys

EDIT KEYS

- DELETE: Erases the character under the cursor and does not repeat.
- BACKSPACE: Deletes the character to the left of the cursor and will continue to delete when held down.
- ENTER: Completes entries and enacts changes.

ARROW KEYS

- Keys that provide cursor movement and screen scrolling.

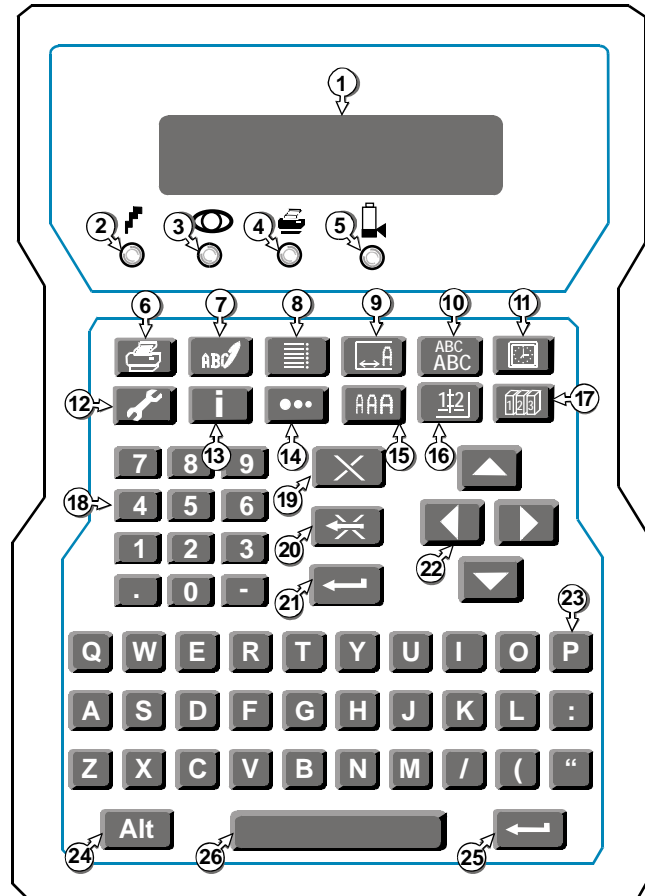

ALPHABETIC KEYS

- Keys for character entry. Each character will show alternate characters when scrolled with the up and down arrow keys.

ALTERNATE KEYS

- ALT: Provides alternate characters and functions when used in combination with other keys.
- ENTER: This key duplicates the function of key 21

SPACE BAR

- Enters spaces in messages; can be scrolled with the up and down arrows to show alternate characters

Printing a Message

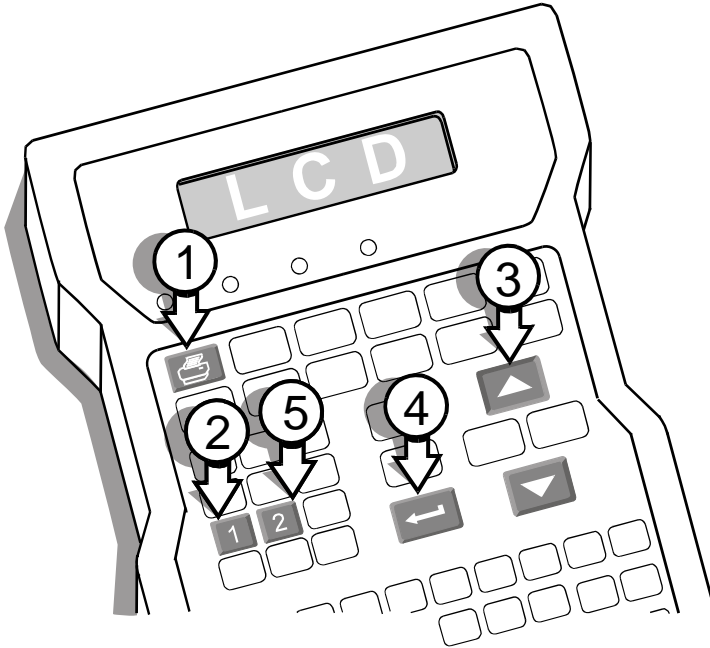

- 1 Press PRINT and the LCD will show "1-Print" and "2-Stop Print".

```
1-Print
2-Stop Print
```

- 2 Press 1 and the LCD will show the name of the last message printed and its corresponding text.

```
Name: TEST 123
TEST 123<
```

The screen example above shows the message created at the factory.

- 3 Scroll until the message to print appears on-screen.



- 4 Press ENTER to print.

- 5 Press 2 to stop printing.

The print sample below is the default message printed with controller default settings.

TEST 123

This feature is a part of sample message G1.

Creating a Simple Message

A2

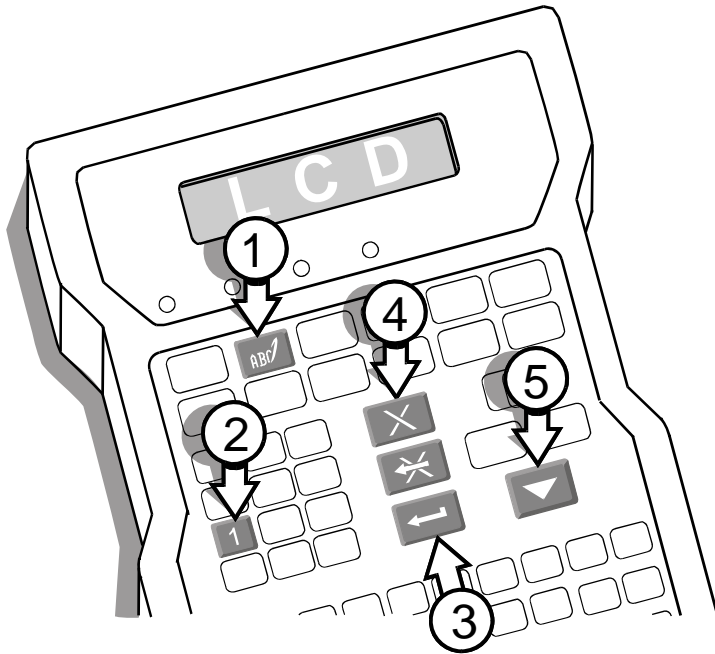

- 1 Press EDIT and the LCD will show "1- Press 1 and the LCD will prompt for a name for the new message.

Name:
█

- 3 Type a name and press ENTER.

Name:
TESTMESSAGE█

- 4 Type a simple message of letters and numbers only, no codes. Correct mistakes with DELETE and BACKSPACE.

Editing...
123TESTING123<

- 5 Press ENTER to finish the message. The LCD will offer three choices:

1-Save:TESTMESSAGE
2-Cancel changes: T↓

2-Cancel changes: TE
3-Edit: TESTMESSAGE

NOTE: a down arrow on the LCD indicates that this menu has more than two selections.

- 6 Press 1 to save the new message.

This feature is a part of sample message G1, G2, G3, G4 and G5.

Editing a Message

A3

- 1 Press EDIT and the LCD will show “1-New Message” and “2-Edit Message.”
- 2 Press 2 and the LCD will show a message. If you want to edit the message on-screen, press ENTER.

Name: **TESTMESSAGE**
123TESTING123<

If you want to edit another message, scroll until your message appears and press ENTER.

- 3 Type changes. Use BACKSPACE and DELETE to remove unwanted characters.
- 4 Press ENTER to finish editing. The LCD will offer three choices:

1-Save: **TESTMESSAGE**
2-Cancel changes: T↓

2-Cancel changes: TE
3-Edit: **TESTMESSAGE**

NOTE: A down arrow on the LCD indicates that this menu has more than two selections.

- 5 Press 1 to save the edits.

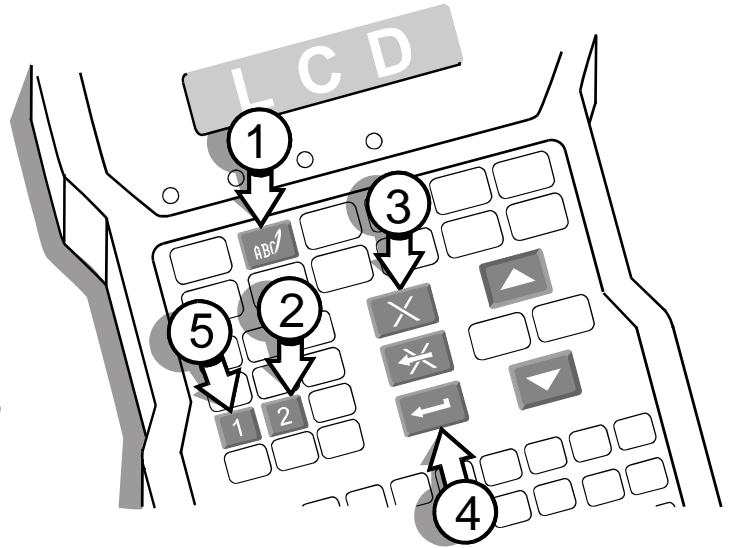

This feature is a part of sample message G1, G2, G3, G4 and G5.

Deleting a Message

A4

- 1 Press EDIT.
- 2 Press 3 for “Delete Message.” The LCD will show the name of a message and its content.
- 3 Scroll until the message to delete is on-screen.
- 4 Press ENTER. The LCD will prompt to cancel the changes or delete the message:
- 5 Press 2. The message is now deleted and the LCD shows the Edit screen:

Name: **MESSAGE**
MESSAGE<

Name: **TEST MESSAGE**
12134567890<

1-Cancel Changes: **TE**
2-Ok. Delete: **TEST M**

2-Edit Message
3-Delete Message

Viewing System Information

A5

- 1 Press INFORMATION.
- 2 Scroll up and down to see all choices.
- 3 Press ENTER at any menu entry to see the associated detail. The chart below left shows all prompts with explanatory notes.
- 4 Press ENTER when done.



Menu Selection	Explanation
1-Unused Messages	This selection shows the number of available messages. The system can store 99 messages.
2-Date	This selection shows the date currently set in the system in the year, month and day format.
3-Time	This selection shows the time set in the system in hours, minutes and seconds.
4-Print Speed	This selection shows the speed recorded by the photosensors during the last printing session.
5-Item Count	This selection shows the number of times the current message has been printed.
6-Version	This selection shows the version of firmware in your controller.
7-Support/Supplies	This selection displays information on supplies and support for your Ink Jet printer.

Frequently Asked Questions (FAQs)

A6

Q1 How do I create a message?

A1 Follow the directions in Instruction A2, "Creating a Simple Message". See G1 for an example of a new message.

Q2 How do I change the parameters of a message I have already created?

A2 See Instruction A3, "Editing a Message." Determine what variables are in your message such as Item Count (E5) and Date (E1) and review Section D that explains how to set variables and Section E that explains how to insert variables in messages.

Q3 How do I select and print a message?

A3 1 Press PRINT.

2 Press 1. The top line of the LCD will show the name of the message and line two will show the message contents.

Name: MESSAGE MESSAGE<



3 Scroll through message names until you find the one to print.

4 Press ENTER to print.



Q4 What do I do if my print quality does not match the quality of the print sample supplied with the unit?

A4 Determine exactly how your print differs from the supplied sample. Is it too light? Is it missing dots? Look in Section H, "Troubleshooting" to find the solution to your printing problem.

Frequently Asked Questions (FAQs)**continued A6**

- Q5 If I am using sequential numbers while printing and stop the print, what number will the print start with when I send it to print again?**
 A5 *The numbers will start over again. Specifically, they will begin with the starting number specified in either “Setting the Item Count (D6)” or “Setting a Pallet Count (D7)”.*
- Q6 What do I do if I see no image printed on the substrate but I see that the message has been sent to print?**
 A6 *See Section H, “Troubleshooting.”*
- Q7 How far will the built-in photosensors “see”?**
 A7 *The photosensors should be placed no farther than one-quarter inch from the product.*
- Q8 What do I do if the unit is printing in the wrong area on the case or between cases?**
 A8 *See Section H, “Troubleshooting.”*
- Q9 What do I do with the unit if I won't be using it for a week or more?**
 A9 *Purge the system with conditioner. See Instruction B4 for details on flushing.*
- Q10 Can I turn the printhead straight up and print on the bottom of the product?**
 A10 *No.*
- Q11 Can I print upside down?**
 A11 *Inverted printing requires no changes in position of the printhead or its bracket—the controller has been programmed to print upside down messages. Follow the directions in Instruction C8, “Rotating the Message.”*
- Q12 What happens if I unplug the unit?**
 A12 *The controller memory retains your messages and parameters.*
- Q13 How often should I purge?**
 A13 *Purge at the start of each workday or more often in dusty environments.*
- Q14 Do I have to stop printing to put in a new can of ink?**
 A14 *No. There is enough ink in the ink delivery system to allow continuous printing while you install a new can of ink.*
- Q15 If I get lost in a menu, what button should I press to find my way again?**
 A15 *INFORMATION () is a safe key to press if you are unsure about editing, printing or working in the Set-Up menu. Some of the other function keys such as Date and Time, will not let you out of the menu until you have entered a value or pressed ENTER.*
- Q16 The character I want to print isn't on the keyboard.**
 A16 *All alphabetic and numeric keys on the keypad can display alternate characters when used with the up and down arrows. The English vowel set and the consonants C, N and Y have alternate characters with phonetic marks such as the umlaut (¨) and the acute accent (´). All consonant keys provide access to the entire alphabet in both uppercase and lowercase. The punctuation keys provide multiple punctuation marks. Follow the directions in Instruction E7, “Using Alternate Characters” to create messages with characters not on the keyboard.*

Maintenance

B

Loading Ink

B1



Do not stop printing when you run low on ink. The system has enough ink in its delivery system to continue printing until you install a fresh can.

- 1** Unscrew the old can and set aside.
- 2** Remove the cap from the new can, invert and screw into the ink receptacle. Make sure that the ink can adapter and the receiver on the ink delivery system are the same color.

Black adapter and black receiver indicate water-based porous.

Red adapter and red receiver indicate alcohol-based non-porous.



- 3** Dispose of the old can in accordance with local, state and federal regulations.

NOTE: When the ink can empties, ink pressure drops below normal operating pressure. This causes ink to collect on the face plate. The face plate should be cleaned every time the ink can is replaced.

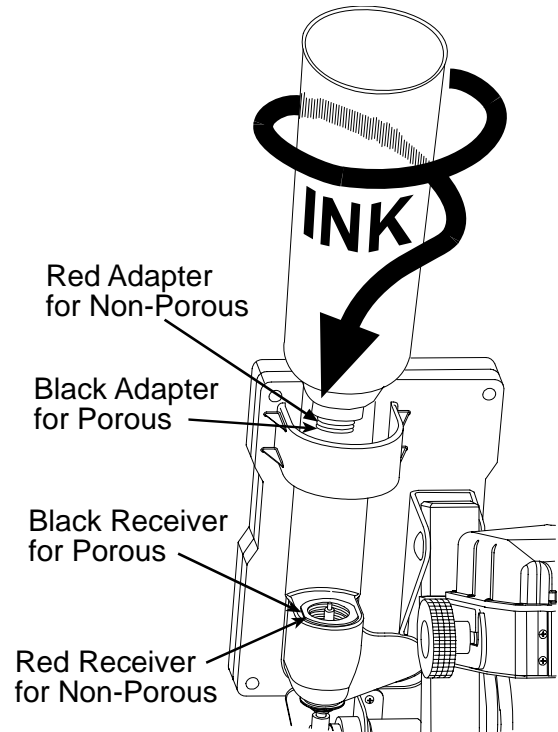

CAUTION

1. Use only water-based porous inks, identified with *black* fittings, for porous printers with *black* receivers.
2. **DO NOT SHAKE THE INK CAN.**

CAUTION

1. Use only alcohol-based non-porous inks, identified with *red* fittings, for non-porous printers with *red* receivers.
2. **DO NOT SHAKE THE INK CAN.**

Purging All Channels

B2



Purge the printer at the start of the workday.

- 1 Hold a disposable towel in front of the printhead.
- 2 Press PURGE.



Hold for long purge
Purge 96/100<

The printhead will expel ink for approximately two seconds.
Continue to press PURGE if you want a long purge of ink.

- 3 Clean the face of the printhead with Maintenance Spray.

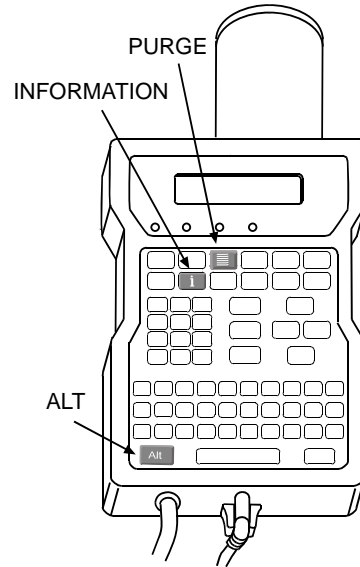

Purging a Single Channel

B3



Purge a single channel when a dot is missing or undersized.

- 1 Press and hold ALT and PURGE.

Dot: 7
Press i to exit

- 2 Press the corresponding numeric key to select a channel to purge.
- 3 Hold a disposable towel in front of the printhead.
- 4 Press PURGE.



The printhead will expel ink for approximately two seconds.

- 5 Spray the face of the printhead with Maintenance Spray.
- 6 Press **i** (INFORMATION) to exit or enter another channel to purge and repeat steps 3 and 4.

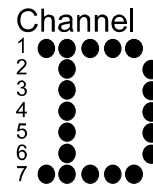

Purging with Conditioner

B4



Extended shutdowns will require purging the printhead with conditioner.

- 1 Remove the ink canister and attach a canister of conditioner.
- 2 Hold a lint-free disposable cloth in front of the printhead.
- 3 Press PURGE.
- 4 Continue to press PURGE until the expelled fluid is clear.
- 5 Remove the conditioner and attach the ink canister.



Broaching the Orifice

B5



If a printhead orifice is clogged or obstructed, and wiping the front plate and purging will not clear it, the appropriate orifice should be broached.

- 1** Make sure the broach pin does not extend out of the handle any more than 0.10 inch.
- 2** Wipe the front plate clean with a cloth and conditioner.
- 3** Identify the clogged orifice by identifying the missing dot(s) from a print sample.
- 4** Count the orifices one the front plate up or down until you locate the clogged orifice. A flashlight or other concentrated light source will help, as the orifices are very small.
- 5** Carefully insert the broach pin in the clogged orifice until the handle touches the front plate. Remove the broach pin from the orifice and create a print sample.
- 6** If the print sample shows that the orifice is still clogged, purge the printhead and make a second print sample.
- 7** If the orifice is still clogged, count the orifices again to make sure that you are broaching the correct orifice, then repeat steps 5 and 6.

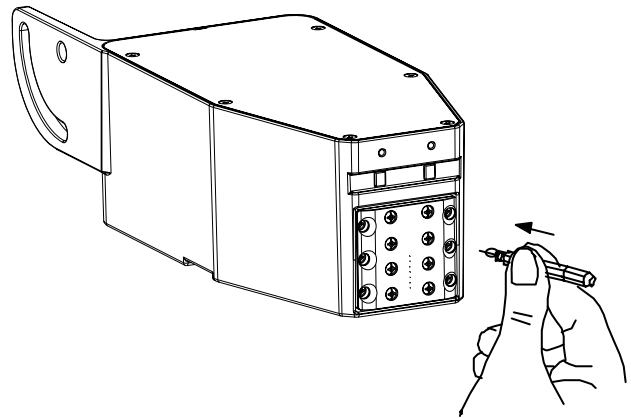
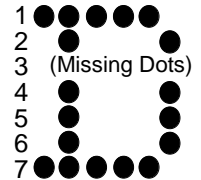
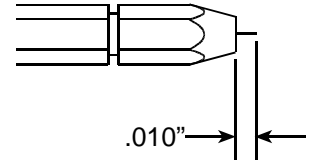

Startups & Shutdowns

B6

Overnight Shutdown

To keep the printheads running smoothly, spray the printhead face with Maintenance Spray and use a cloth to catch the fluid as it runs off the faceplate.

DO NOT WIPE THE FACEPLATE.

Overnight Startup

Spray Maintenance spray onto a clean, lint-free cloth and wipe the face plate of the printhead. Purge with ink by pressing PURGE. If any of the channels are not ejecting ink, follow the directions on B3, Purging a Single Channel.

Shutdown for Seven Days or More



For shutdowns lasting a week or longer, it may be necessary to flush all printheads with Conditioner. Flush and thoroughly purge the printhead. Keep a cloth handy for wiping up excess ink.

- 1** Remove the ink can and attach the effluent bottle kit (5750-503) to the male fitting on the back of the printhead. Make sure that the valve on the effluent line is closed.
- 2** Insert a can of Conditioner in the ink receptacle.
- 3** Open the valve in the effluent line. Allow the liquid to empty into the effluent bottle until it runs clear.
- 4** Close the valve in the effluent line and disconnect it from the ink outlet in the back of the printhead.
- 5** Hold a clean wipe in front of the printhead and press PURGE several times to clean printhead orifices.
- 6** Insert the ink can.

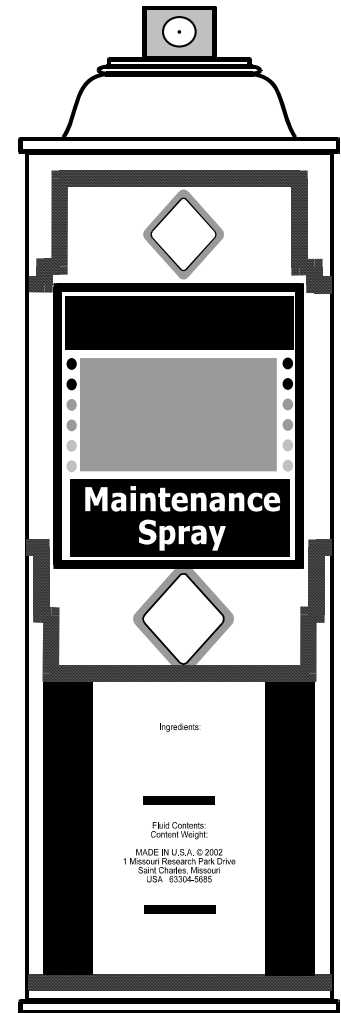

If You Purchased Spare Printheads

Spare printhead(s) should be circulated into operation on a regular basis. Rotate the printheads every couple of months to keep them performing up to expectations. Rotating spare printheads prevents hardening of the internal printhead components, making startup much easier. Before returning a spare printhead to the shelf, please be sure to thoroughly flush with conditioner.



CAUTION

- 1. Use only water-based porous inks, identified with *black* fittings, for porous printers with *black* receivers.**
- 2. DO NOT SHAKE THE INK CAN.**

CAUTION

- 1. Use only alcohol-based non-porous inks, identified with *red* fittings, for non-porous printers with *red* receivers.**
- 2. DO NOT SHAKE THE INK CAN.**

Changing Ink Colors

B7



Changing colors of ink requires complete flushing of the printhead.

- 1** Disconnect the original can of ink.
- 2** Attach the effluent bottle kit to the male OUT fitting on the back of the printhead (**A**). Make sure that the valve on the effluent line is closed (**B**).
- 3** Insert a can of conditioner in the ink receptacle.
- 4** Open the valve (**B**) in the effluent line. Allow the liquid to empty into the effluent bottle (**C**) until it runs clear.
- 5** Close the valve on the effluent line.
- 6** Remove the can of conditioner and insert the can of ink with the new color.
- 7** Open the valve on the effluent line and allow the fluid to run out until the color is undiluted. Turn off the valve.
- 8** Disconnect the effluent line from the back of the printhead. Clean up any drips with a lint-free wipe.
- 9** Hold the wipe in front of the printhead and press PURGE repeatedly until the printhead ejects undiluted ink.

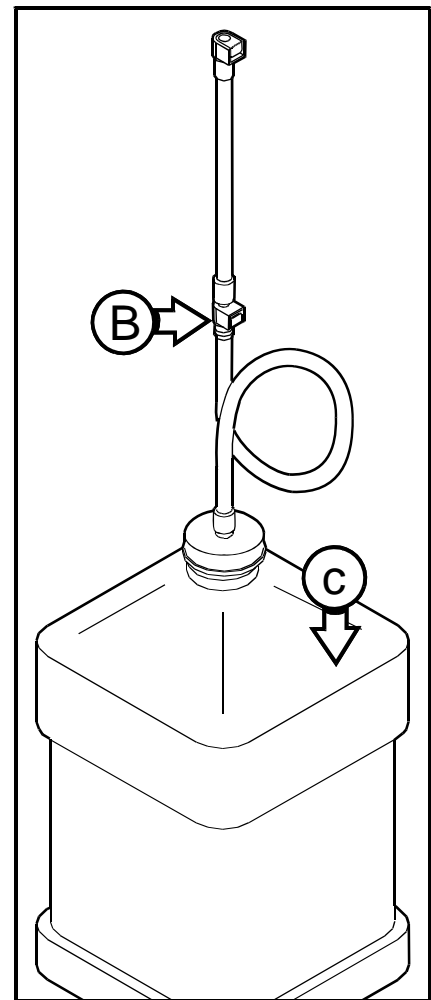
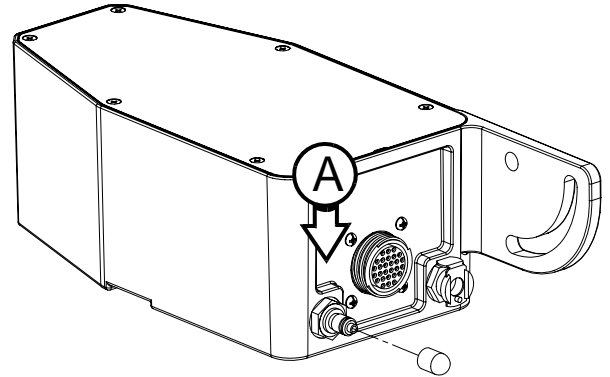

Adjusting the Screen Contrast

B8

You can change the contrast on the LCD by using the UP and DOWN arrows with ALT.

- 1 Press and hold ALT and the DOWN arrow. Hold for at least five seconds. The screen contrast will gradually dim.
- 2 Press and hold ALT and the UP arrow. Hold for at least five seconds. The screen contrast will gradually become sharper.

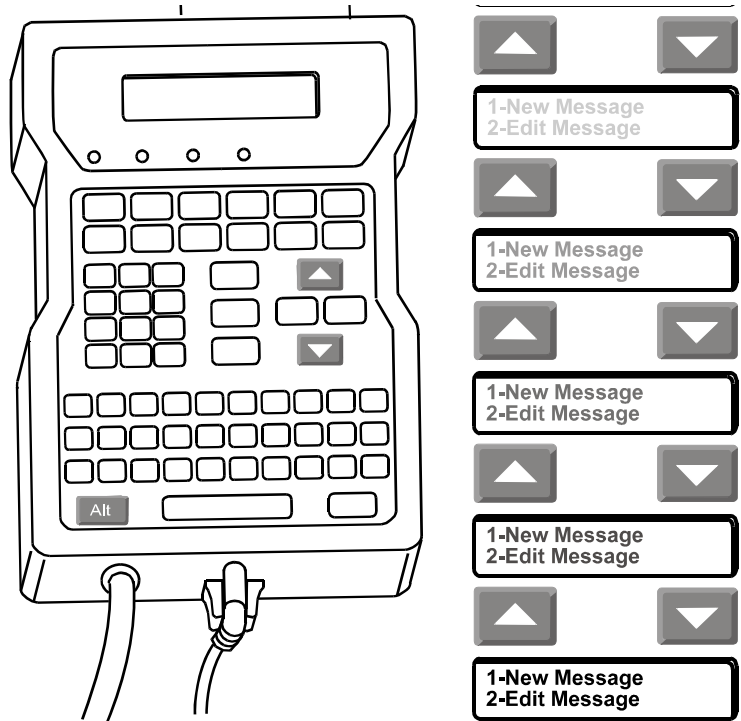

Resetting Factory Defaults

B9

If you want to reset your printer to factory defaults, unplug the controller. If you want to see the factory-default values before you change the settings, look at the label on the printhead that shows the values set in final assembly for optimal performance.

- 1 Press and hold ALT and the decimal point on the numeric keypad.
- 2 Reconnect power. Release the keys when the LCD asks if you want to "Erase All Messages?"

Erase all messages?		
1-No	2-Yes	:2

- 3 Make your selection and press ENTER.
The controller will initialize and you must set a language for the LCD, the date, the time and the units of measurement.

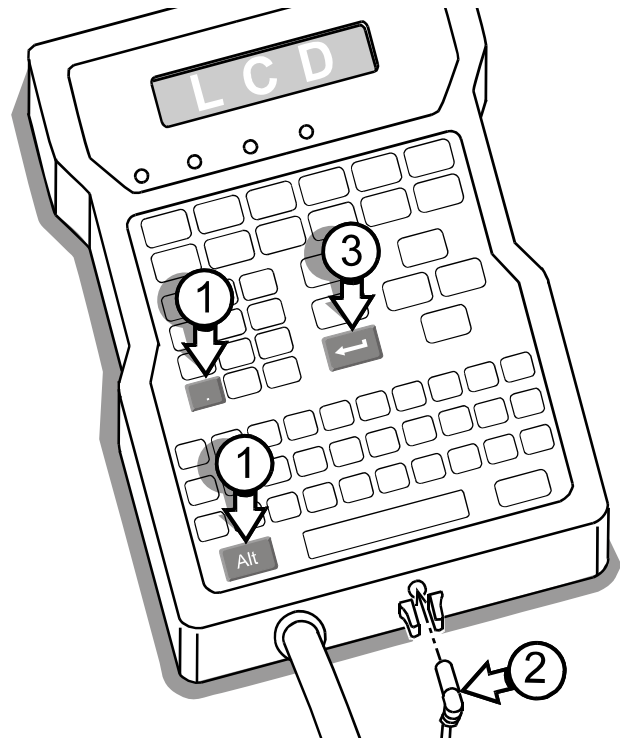

Print Adjustments

C



Changing an Individual Message Indent

C1

The message indent is the distance from the leading edge of the product to the starting character of the message. The system default for message indent is 0.5 inches (12.7 mm).

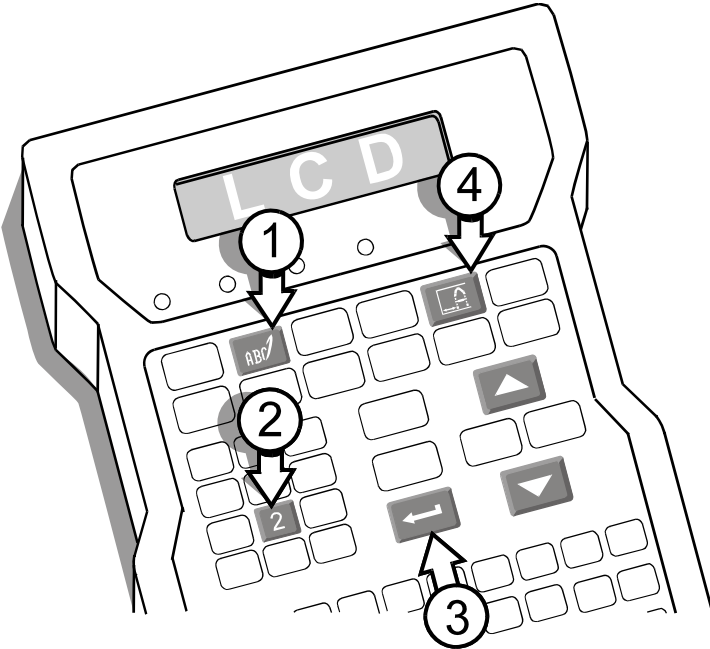
Using the indent function while editing gives the message an indent value different from the default indent distance. This feature is useful when printing on products of varying sizes.



- 1** Press EDIT. 
- 2** Press 2 and scroll until the target message is on-screen. 
- 3** Press ENTER.
- 4** Press INDENT, move the cursor to the number for change and type in a new indent value.

Set Message Indent:
001.0 inches

- 5** Press ENTER to finish.

Setting the Default Message Indent

C2

CHANGING MESSAGE INDENT *The indent distance set in this routine will be the default indent for all messages created in the future. To change the indent distance in an existing message, follow the directions in Instruction C1, “Changing an Individual Message Indent”.*

The message indent is the distance from the leading edge of a product to the first printed character. For products moving from right-to-left, the first printed character will be the beginning of the message. For products moving from left-to-right, the first printed character will be the end of the message.

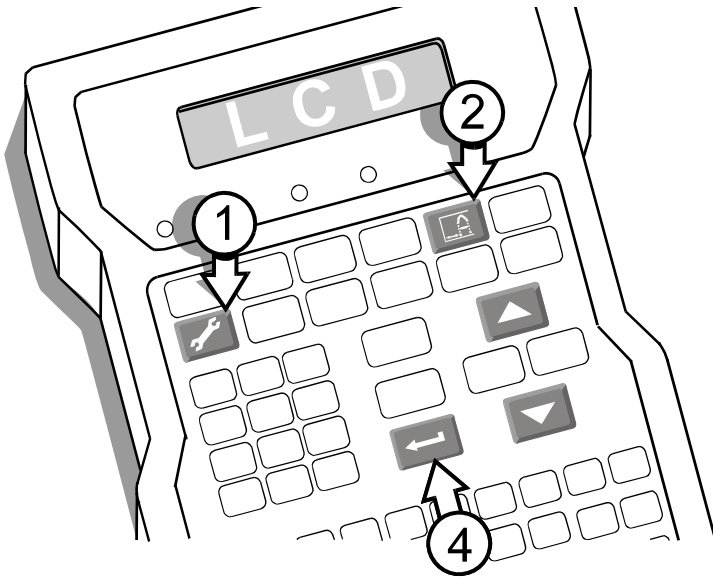

- 1 Press SET-UP.
- 2 Press INDENT.
- 3 Type in indent value.

Set Message Indent:
001.0 inches

- 4 Press ENTER when done.

Changing the Character Width in a Message

C3

Changing the Character allows you to change the horizontal dots in a printed character. The default value is 6.

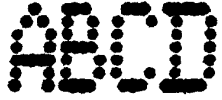
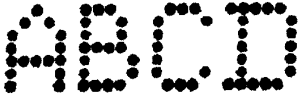
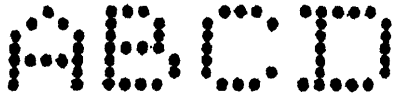
Character Width 1	Character Width 4	Character Width 6
		

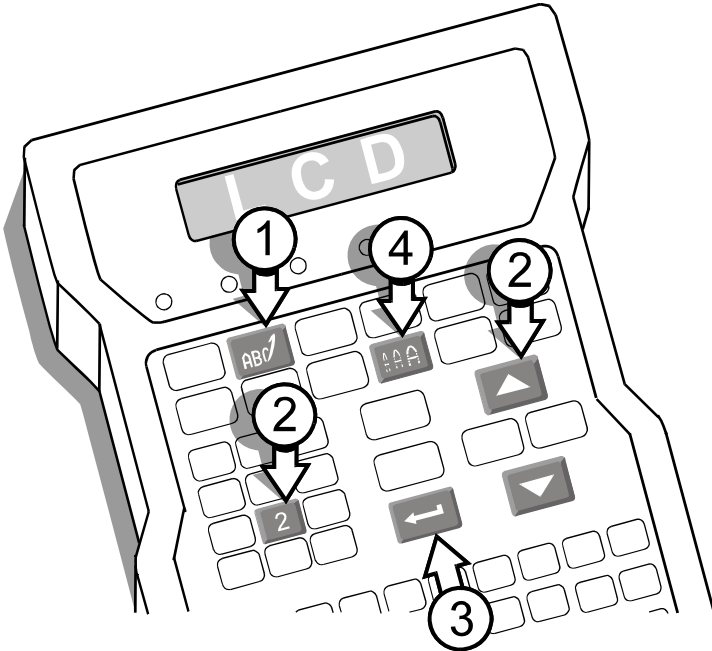

- 1 Press EDIT.
- 2 Press 2. Scroll until the target message is on-screen.

▲
▼
- 3 Press ENTER.
- 4 Press CHARACTER WIDTH.
- 5 The LCD will show a range of 1 (narrow) to 9 (wide).

Set Character Width:
6

Select a new width by scrolling and press ENTER.
- 6 Press ENTER to complete the edit change.

This feature is a part of sample message G5.

Setting the Default Character Width

C4

CHANGING THE CHARACTER WIDTH. *The character width set in this routine will be the default character width for all messages created in the future. To change the character width in an existing message, follow the directions in Instruction C3, “Changing the Character Width in a Message”.*

This feature enables you to set the horizontal space between the dots in a printed character. The default value is 6. See Instruction C3 for scanned samples of different character widths.

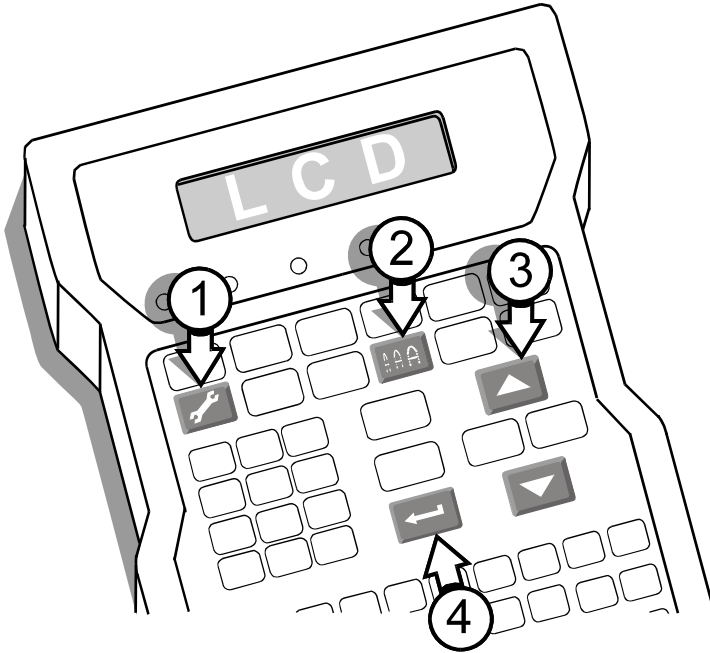

- 1** Press SET-UP.
- 2** Press CHARACTER WIDTH.
- 3** The LCD will show a range of 1 (narrow) to 9 (wide).

Set Character Width:

6

Select a width by scrolling and press ENTER.



- 4** Press ENTER to finish.

Changing the Printed Dot Size

C5

The system allows you to change the diameter of all the dots that form printed characters in a range from 0.05 inch (1.27mm) to 0.10 inch (2.54mm). The default dot size is 4.

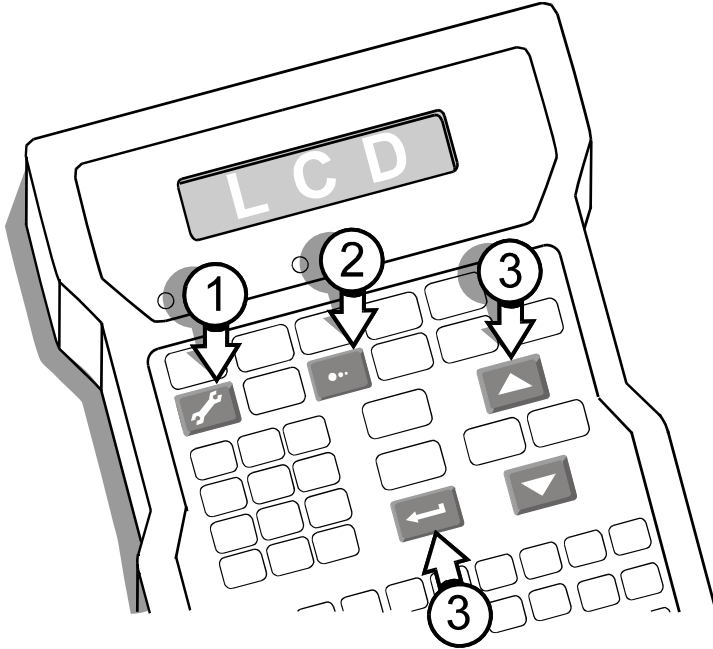

- 1 Press SET-UP.
- 2 Press DOT SIZE. The LCD will prompt for a dot diameter:

Dot diameter (1-9):
4

- 3 Scroll to a new dot diameter and press ENTER.



Try sample prints with the new dot diameter to see if you have improved the printing. If not, change the dot size and run more print samples.

The scanned samples following show the differences in printed characters when the dot size is 3, then 4 and finally 7.

Dot Size 3	Dot Size 4	Dot Size 7
A B C	A B C	A B C

Changing the Font in a Single Message

C6

The system has three fonts: 5 dot-tall, single dot (5S); 7 dot-tall, single dot (7S); and 7 dot-tall with double dots. See scanned samples in Instruction C7.

The routine that follows changes the font in a single message.

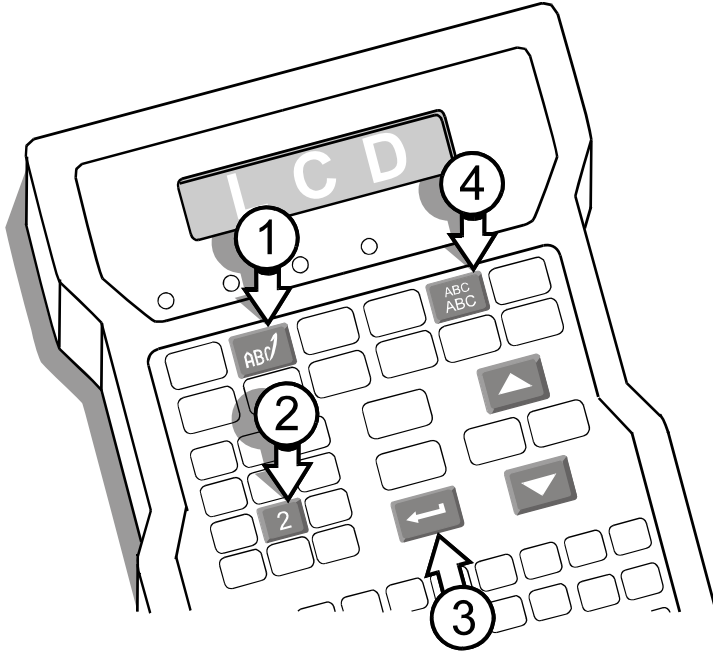

- 1** Press EDIT.
- 2** Press 2 and scroll until the target message is on-screen.

▲

▼
- 3** Press ENTER.
- 4** Press FONT. The LCD will prompt for a font selection.



1:7B 2:7S 3:5S
 Set Font: 3
- 5** Type the number of the new font and press ENTER
- 6** Press ENTER again to finish the edit.

Changing the Default Font

C7

CHANGING THE MESSAGE FONT The font set in this routine will be the default font for all messages created in the future. To change the font in an existing message, follow the directions in Instruction C6, “Changing the Font in a Single Message”.

The system has three fonts:

7B: Double line characters 7 dots tall (“B” for bold).	7S: Single line characters 7 dots tall	5S: Single line characters 5 dots tall.
		

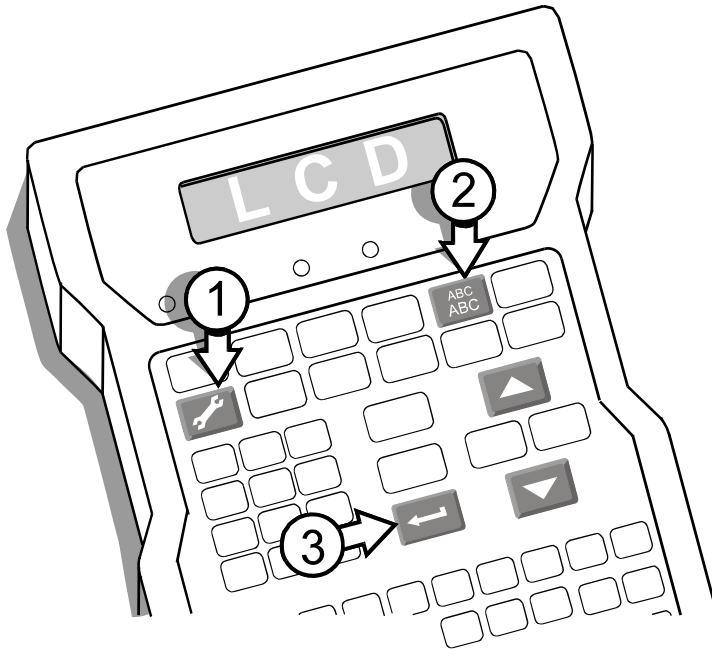

- 1 To change the font, start by pressing SET-UP.
- 2 Press FONT. The LCD will prompt you to select a font.

1:7B 2:7S 3:5S
Set Font: 3

- 3 Scroll to a new font and press ENTER.



Rotating the Message

C8

This function will rotate the printed message 180 degrees, which enables you to print a readable message that is upside down. Rotated messages allow you to print very close to the bottom of a box if the box is moving upside down on the conveyor.

Setting the controller for rotated printing requires accessing a menu that is available only after a special initialization. Start by unplugging the barrel connector from the system.

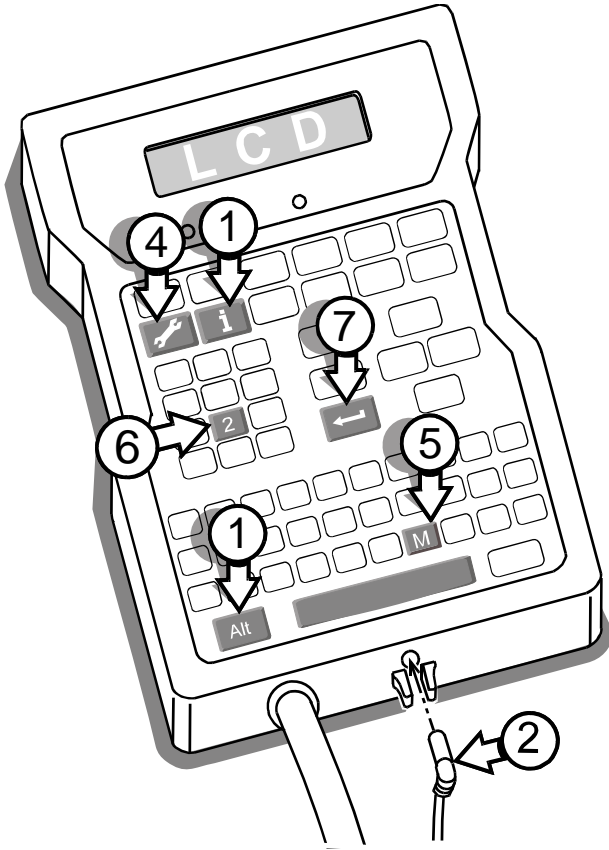

- 1** Press and hold ALT+INFORMATION.
- 2** Plug in the barrel connector.
- 3** Release the keys when the LCD shows "Information".

Information 1-Unused Messages
--

- 4** Press SET-UP.
- 5** Press M on the QWERTY keypad. The LCD will prompt for a rotated message.

Rotate Message? 1-No 2-Yes :1
--

- 6** Press 2 to rotate the message.
- 7** Press ENTER to finish.

Adjusting a Single Dot Diameter

C9

This function allows you to change the dot diameter of individual dots from top to bottom by altering the stroke, in microseconds, of a piston in an ink channel. When the dots in a row are too small, they require a dot-size increase. If they are too large, they require a dot-size decrease.

Changing individual dot diameters requires a menu that is available only after a special initialization. Start by unplugging the system.

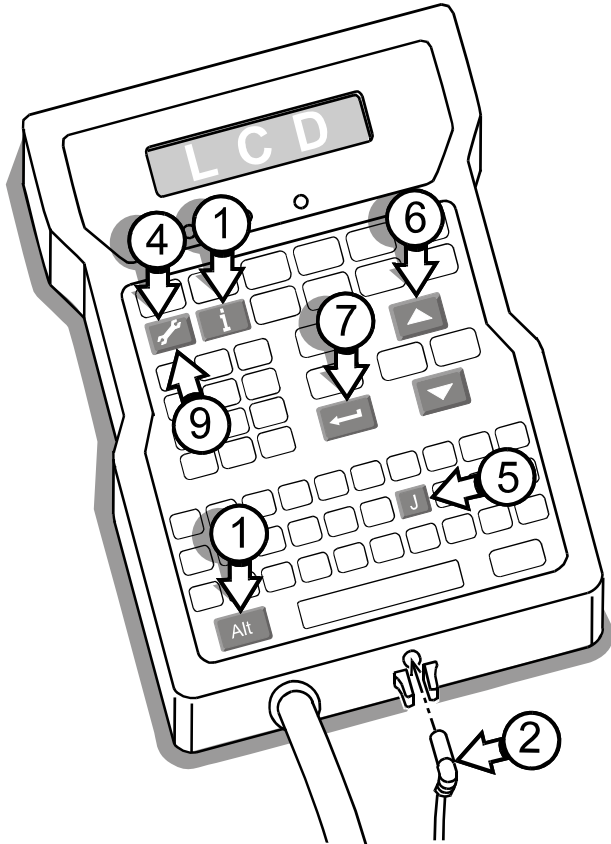

- 1 Press and hold ALT+INFORMATION.
- 2 Plug in the barrel connector.
- 3 Release the keys when the LCD shows "Information."

Information
1-Unused Messages

- 4 Press SET-UP
- 5 Press J on the QWERTY keypad. The LCD will prompt for the number of the dot that is not printing like the other dots. The top dot on the printhead is dot number 1 and the bottom dot is dot number 7.

Dot: 1

- 6 Scroll to the number of the problem dot.
- 7 Press ENTER.
- 8 The LCD will prompt for a new diameter of the selected dot. Move to the second digit (25) and scroll to a new value. The scroll changes by units of 10.

- 9 Press SET-UP. The LCD will ask if you want to keep the "Factory Setting Y/N?" Select "1-NO." When you select NO, the system remembers the dot diameter only until the next initialization. By running print samples and altering dot diameters, you can change a single dot until it matches the other dots.

- 10 When you achieve the best print, select "2-YES" when exiting this function. This choice makes the dot diameter value permanent.

The scanned samples below show the changes in appearance of a single dot with different diameters.

Dot #4 reduced by 25	Dot #4 at preset value	Dot #4 increased by 40

First Dot Adjustment

C10

When the system has not printed for several minutes, the first dots printed in a message can be too small. You can prevent these initial small dots with First Dot Adjustment, which increases the dot sizes only on the first print. Dots in the second and all subsequent messages return to their defined dot-size settings, depending on the dot-size you choose. First dot adjustments are made at the factory but may require fine-tuning.

Adjusting the first dot size requires a menu that is available only after a special initialization. Start by unplugging the system.

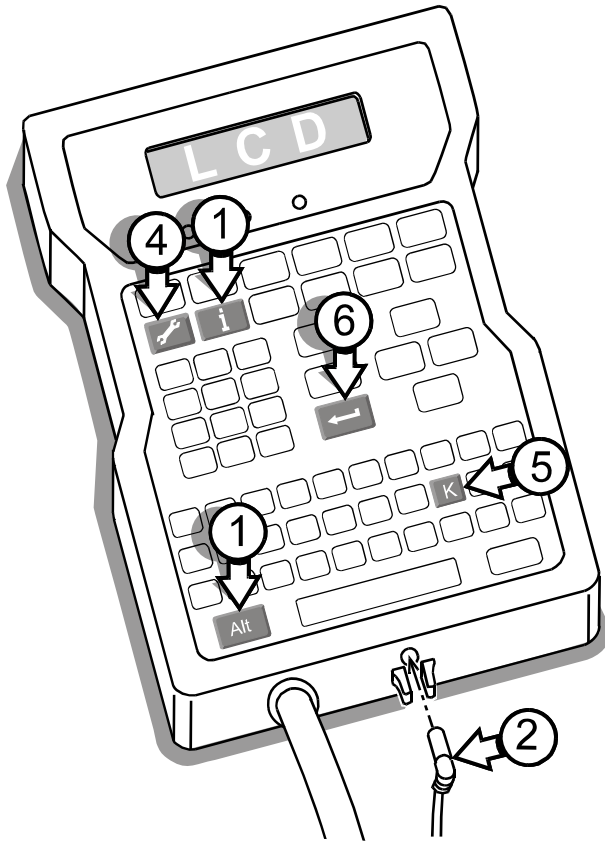

- 1 Press and hold ALT+INFORMATION.
- 2 Plug in the barrel connector.
- 3 Release the keys when the LCD shows "Information."

Information
1-Unused Messages

- 4 Press SET-UP
- 5 Press K on the QWERTY keypad. The LCD will prompt for the time in seconds that the printer will stand idle."

1st dot time:000 sec

- 6 Type in the amount of time and press ENTER.
- 7 The LCD will show "1st Dot Adjust:1" for the first valve (dot) at the top of the printhead. Press ENTER.

1st dot adjust:1
Dot Adjustment:30

The second line of the LCD will prompt for "Dot Adjustment." If this dot is small in the sample print (see the first sample below), increase the value by 10 which increases the size of the dot for the first print. If the dot was full-size, DO NOT enter a new value: leave the existing value and press ENTER

- 8 The display will change to "1st Dot Adjust:2" for the second valve. Press ENTER and the second line will prompt for "Dot Adjustment." Repeat this process through all seven dots.
- 9 After the seventh dot, press SET-UP. The LCD will prompt for "Factory Setting." Select "2-YES." Wait the time designated in step 5, then print a message. If the print is satisfactory, unplug and replugin to set the system in print mode. If the print is unsatisfactory reset the first dot by repeating this procedure (C10) and run another sample. Repeat until you achieve a satisfactory first print.

The scans following show examples of first prints with a problem fourth dot.

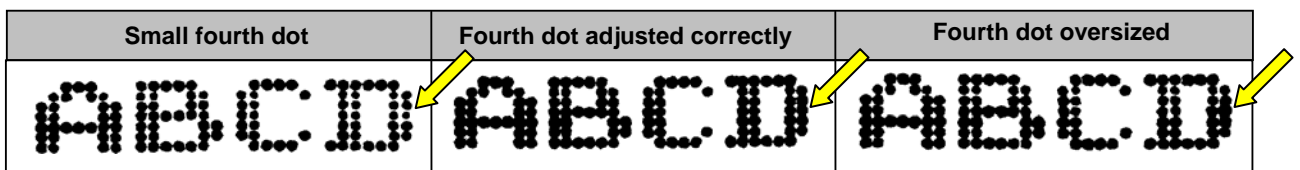

Sizing Dots in Columns

When the system prints a single dot, the printing channel has individual access to ink pressure. When all seven channels print simultaneously, they share the ink pressure. This sharing can produce printed dots in columns that are slightly smaller in diameter than single printed dots. The column dot adjustment enables you to eliminate slight size variances between dots printed in rows and dots printed in columns.

Column dot adjustment requires a menu that is available only after a special initialization. Start by unplugging the system.

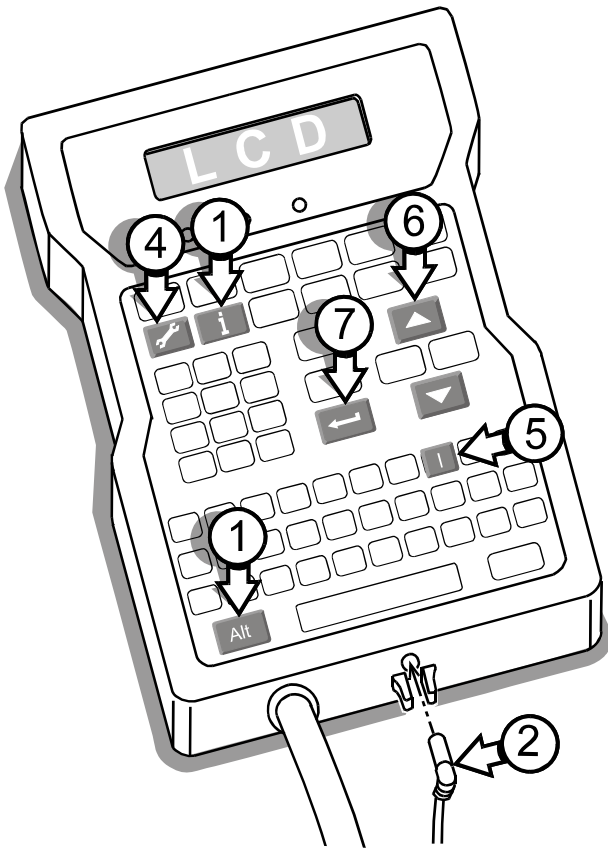

- 1 Press and hold ALT and INFORMATION.
- 2 Plug in the barrel connector.
- 3 Release the keys when the LCD shows "Information."

Information
1-Unused Messages

- 4 Press SET-UP.
- 5 Press I on the QWERTY keypad. The LCD will prompt for a change in value of the column dot adjustment:

Column Dot Adjust:

3

- 6 Scroll to a higher or lower number.



- 7 Press ENTER.
- 8 Run a print sample at the speed of a production run.
- 9 Continue adjusting until the dots in columns match the size of dots printed in rows.

The scanned samples below show the adjustments that can be made to dots in columns.

Dots with column adjustment set too low	Nominal letters	Dots with column adjustment set too high

Setting Message Variables

D

Setting the Date

D1

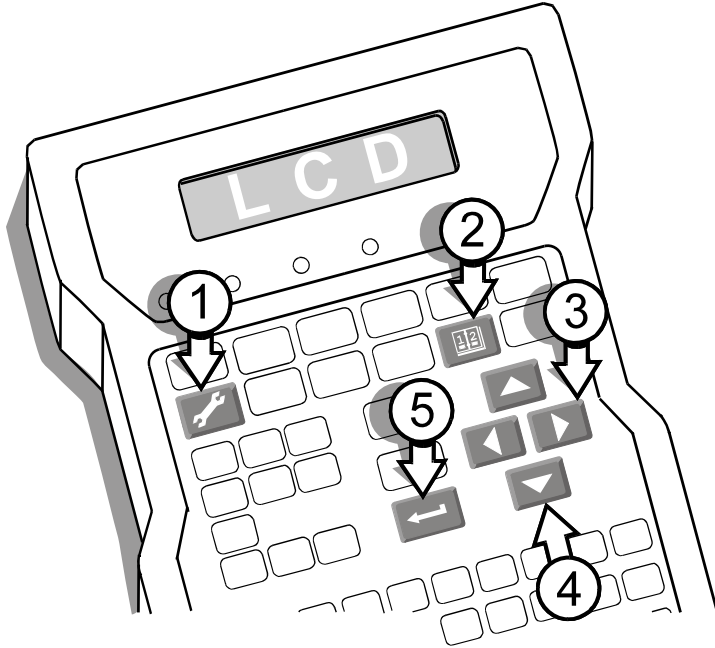

- 1** Press SET-UP.
 - 2** Press DATE. The LCD will show an entry screen with a four-place field for year, two places for the month, and two for the day.
 - 3** Move the cursor to the first number in the year.
- YYYY / MM / DD
1999 11 04
- 4** Scroll to the correct year.

- 5** Press ENTER then move the cursor to the second number in the month field. Scroll to the correct month.

YYYY / MM / DD
2000 11 04

- 6** Press ENTER then move the cursor to the second number in the day field. Scroll to the correct day.

YYYY / MM / DD
2000 12 04

- 7** Press ENTER when done.

This feature is a part of sample message G2 and G3.

Setting an Expiration Date

D2

The system sets an expiration date for a product by adding a user-defined number of days to the system date.

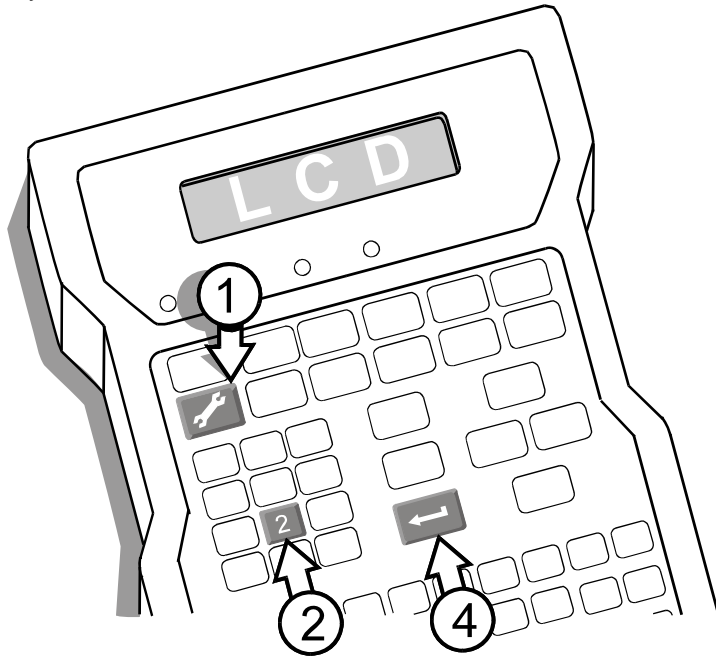

- 1 Press SET-UP.
- 2 Press 2 and the LCD will prompt for the number of days to add to the current system date.

Expiration Days 0000

- 3 Type in the number of days before the product expires.
- 4 Press ENTER to finish.

NOTE: Instruction E2 shows all the various formats available for an expiration date in a message.

This feature is a part of sample message G3.

Setting the Time

D3

- 1 Press SET-UP
- 2 Press TIME. The LCD will show the system time by hours (HH), minutes (MM) and AM or PM.

HH	:	MM	PM/AM
06	:	22	PM

- 3 Move the cursor to the second digit of the entry.
- 4 Scroll until the correct time appears.
- 5 Press ENTER. The cursor will move to the minute (MM) entry.
- 6 Repeat steps 3, 4 and 5 to set the minute entry.
- 7 Type AM or PM to set the time before or after 12 noon.
- 8 Press ENTER when done.

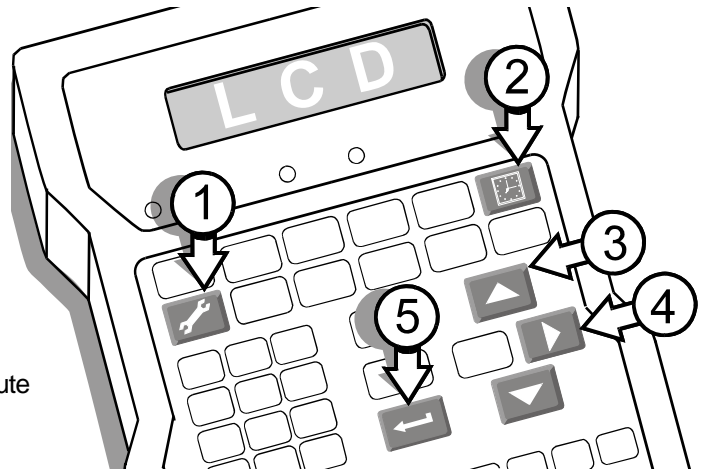

This feature is a part of sample message G5.

Setting Work Shifts

D4

This function enables you to divide the workday into shifts and assign a start time and a name to each shift.

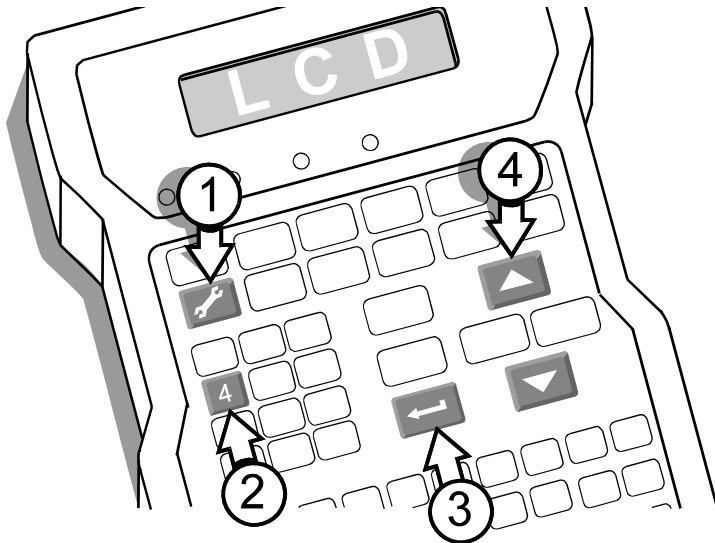

- 1 Press SET-UP.
- 2 Press 4 for “4-Work Shifts.” The LCD will prompt “Set Shifts (1-6).”

Set Shifts (1-6):
Shift: 1

- 3 Type the number of a shift to define and press ENTER.
- 4 The LCD will prompt for a start time from a 24-hour clock.

Start:
03:00

Scroll to the starting hour and press ENTER. The cursor will move to minutes. Scroll to the starting minutes of the hour. Press ENTER.

- 5 The LCD will prompt for the name of the shift.

Shift Name:
A<

Type a name for the shift (1 to 19 alphanumeric characters). This is the name that will print in your messages. The table at right shows the default values. Note that if you use less than three shifts, edit shift 3 by deleting the name “C.”

Shift Number	Start Time	Shift Name
1	08:00	A
2	16:00	B
3	00:00	C
4	00:00	
5	00:00	
6	00:00	

- 6 Repeat steps 2 through 5 to create additional shifts.
- 7 Press SET-UP to exit the work shift set-up.

Setting the Shift Start (Code Date)

D5

Code Date allows you to change the time for work shifts to begin from midnight to another hour in the day.

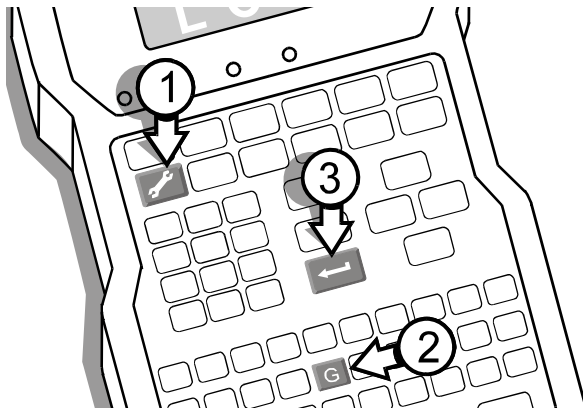

- 1 Press Set-Up.
- 2 Press G for “G-Code Date.” The LCD will prompt for an entry from 0 to 23 that identifies the hour the work shifts start again.

Rollover Hour (0-23):
00

- 3 Type the hour to restart work shifts and press ENTER. If you want to keep the rollover hour at midnight, leave the default value of 00 and press ENTER.

Setting the Item Count

D6

Item count enables you to print increasing or decreasing numbers on each item. If the starting number is smaller than the ending number, the item count will increase with each printed message. If the starting number is larger than the ending number, the item count will decrease with each printed message. When the item count reaches the ending number, it will start again with the starting number. You can define starting and ending values from 0 to 9999999.

The system remembers the item count progression whenever printing stops so that the next print run will start and continue with the previous count. To see the progress of the item count, pallet count or total count, press COUNT  at any time during the print cycle.

Resetting the item count requires editing the message that includes the item count. Whenever you change the parameters of item count, you will need to update all messages that contained item count prior to the change. Update by selecting a message to edit, erasing the old item count and inserting a new one by pressing COUNT.

If you do not have an item count autocode in your message and you press COUNT, you will see "Item Count" above a row of Xs. These Xs mean that either no messages with item count have been printed or no message contains the item count autocode.

- 1 Press SET-UP.
- 2 Press 5 for "5-Item Count." The LCD will prompt for a starting value.

```
Start:
0000001
```

- 3 If you want a starting number other than 1, move the cursor to the right and type a new starting number. Press ENTER.
- 4 Move the cursor to the right and type your ending number. Press ENTER.

```
End
0001000
```

- 5 For "Change" select either 1 or 2 with the arrow keys and press ENTER. Depending on your selection, the item count will increase or decrease by 1 or 2 with each print.

```
Change:
01
```

- 6 The LCD will prompt for the inclusion of leading zeros in the printed item count. Press 2 if you want zeros printed before the number. The width of the greatest count--which can be either the starting or ending number--determines the number of printed zeros.

```
Leading Zero?
1-No 2-Yes :2
```

If you want no leading zeros, press 1.

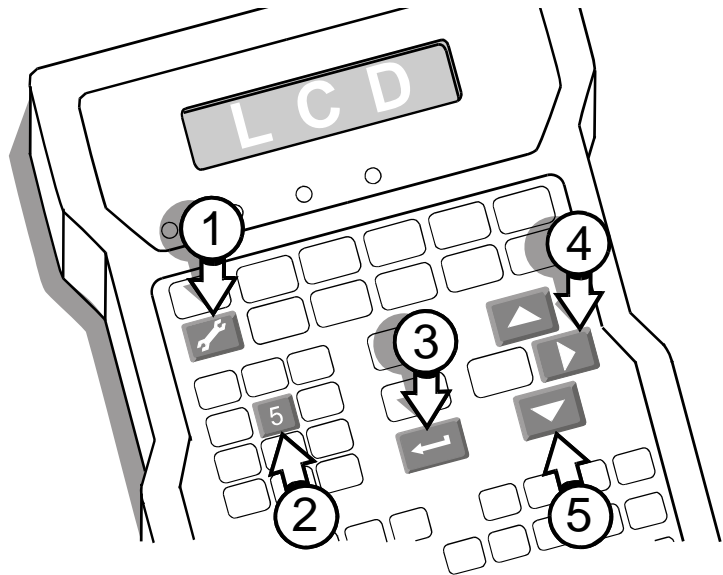

This feature is a part of sample message G2.

Setting a Pallet Count

D7

Pallet Count enables you to print the same number on several products that all belong on the same pallet. For example, defining the pallet quantity as 20, causes the system to print "1" on the first 20 items for the first pallet, "2" on the second 20 items and so on.

The system remembers the pallet count progression whenever printing stops so that the next print run will start and continue with the previous count. To see the progress of the item count, pallet count or total count, press COUNT  at any time during the print cycle.

Resetting the pallet count requires editing the message that includes the pallet count. Whenever you change the parameters of pallet count, you will need to update all messages that contained pallet count prior to the change. Update by selecting a message to edit, erasing the old pallet count and inserting a new one by pressing COUNT.

If you do not have a pallet count autocode in your message and you press COUNT, you will see "Pallet Count" above a row of Xs. These Xs mean that either no messages with pallet count have been printed or no message contains the pallet count autocode.

- 1 Press SET-UP.
- 2 Press 6. The LCD will prompt for the number of items per pallet.

Items per Pallet:
000012

- 3 Move the cursor to the right and type the number of items for each pallet and press ENTER.
- 4 The LCD will prompt for the starting number to print on items for the first pallet.

Start
0000001

Type a number and press ENTER.

- 5 The LCD will prompt for the "End" number, the number to print on items for the last pallet. Type a number and press ENTER.

End
0000100

- 6 The LCD will prompt for the inclusion of leading zeros in the pallet count. Press 2 if you want zeros printed before the number. The width of the greatest count--which can be either the starting or ending number--determines the number of printed zeros.

Leading Zero?
1-No 2-Yes :2

If you want no leading zeros, press 1.

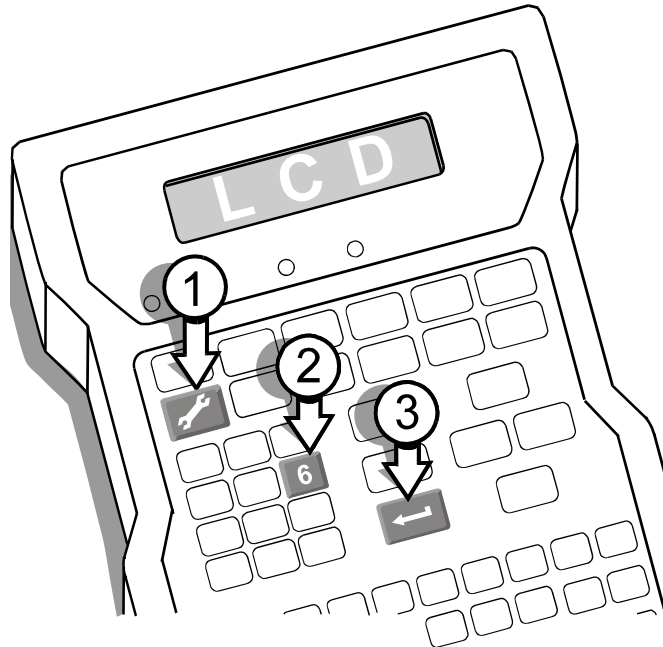

This feature is a part of sample message G6.

Placing Variables in Messages

E

Placing the Date in a Message

E1

You must be in the edit mode to place a date in a message or change the format of the date. See Instruction A2, “Creating a Simple Message” to enter the edit mode.

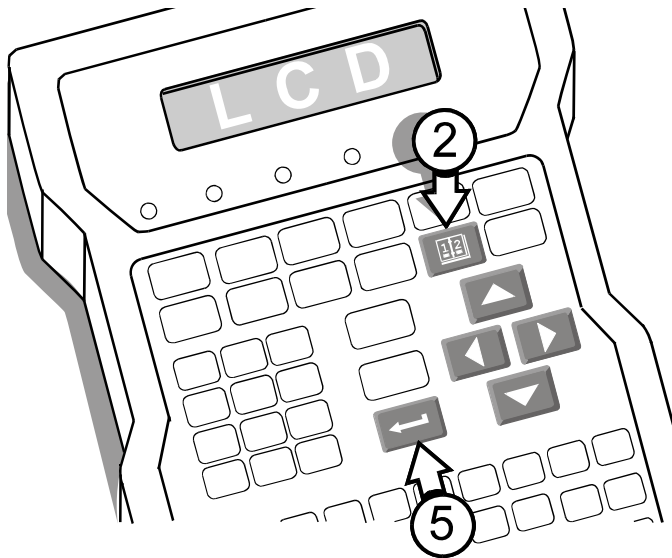

- 1 While editing, position the cursor where you want a date to appear.
- 2 Press DATE. The LCD will show the date enclosed by braces. The braces appear only on-screen, not in the printed message.
- 3 Position the cursor under the initial brace of the message date. The first line of the LCD will now show the format of the message date in an abbreviated form.

DD/MM/YY
 { 04 / 07 / 01 } SHIPMENT
- 4 To change the date format, use the UP and DOWN ARROWS.

The chart below shows all the available date formats on the system with examples for July 4, 2001.

Date in Message	Format Prompt	Explanation
{07/04/01}	MM/DD/YY	Two digits each for the month / the day / the year.
{JUL}	MON-ENGLISH	Month in three letters abbreviated from English
{A}	W/W	Current week as two alphabets. Week 53 = *
{G}	M	Month in a single letter: Jan is A, Feb is B, and so on.
{27}	WW	Current week as two digits.
{185}	DDD	Day of the year in three digits.
{07}	MM	Month in two digits.
{04}	DD	Day of the month in two digits.
{JUL}	MON	Month in three letters abbreviated from selected language.
{01}	YY	Last two digits of the year.
{2001}	YYYY	Year in four digits.
{04/07/01}	DD/MM/YY	Two digits each for the day / the month / the year.

- 5 Press ENTER when done.

This feature is a part of sample message G2.

Placing the Expiration Date in a Message

E2

You must be in the edit mode to place an expiration date in a message or change the format of the expiration date. See Instruction A2, "Creating a Simple Message" to enter the edit mode.

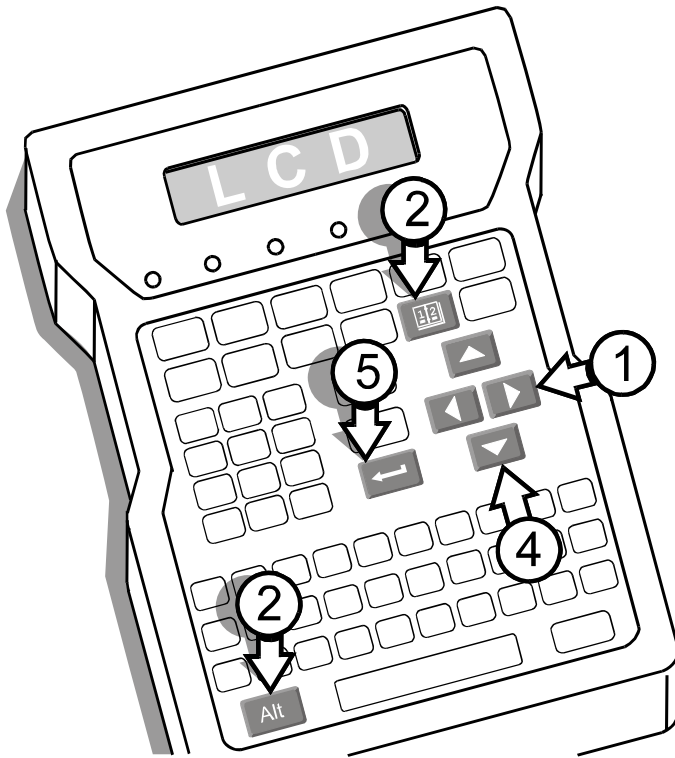

- 1 While editing, position the cursor where you want the expiration date to appear.
- 2 Press ALT+DATE. The LCD will show the expiration date enclosed by braces. The braces appear only on-screen, not in the printed message.
- 3 Position the cursor under the initial brace of the expiration date. The first line of the LCD will show the format of the expiration date in an abbreviated form.

XDD/MM/YY
 { 04 / 08 / 01 } SHIPMENT

- 4 Scroll to change the format.



The chart below shows all the available expiration date formats on the system with examples for August 4, 2001.

Date in Message	Format Prompt	Explanation
{04/08/01}	XDD/MM/YY	Two digits each for the day / the month / the year.
{08/04/01}	XMM/DD/YY	Two digits each for the month / the day / the year.
{04/AUG/01}	XDD/MON/YY	Two digits for the day, three letters for the month and two digits for the year.
{AUG}	XMON-ENGLISH	Month in three letters abbreviated from English
{H}	XM	Month in a single letter: Jan is A, Feb is B, and so on.
{216}	XDDD	Day of the year in three digits.
{31}	XWW	Week as two digits.
{2001}	XYYYY	Year in four digits.
{01}	XYY	The last two digits of the year.
{08}	XMM	Month in two digits.
{AUG}	XMON	Month in three letters abbreviated from selected language.
{04}	XDD	Day of the month in two digits.
{AUG 01}	XMON YY	Month in three letters and the year in two digits

- 5 Press ENTER when done.

INDIVIDUAL EXPIRATION DATES - The expiration date set in this procedure will be the default expiration date for all future messages. To override this default for a single message, select the message while in the edit mode. Press ALT+DATE, type a new number and then press ENTER.

This feature is a part of sample message G3.

Placing the Time in a Message

E3

You must be in the edit mode to place the time in a message or change the format of the time. See Instruction A2, “Creating a Simple Message” to enter the edit mode.

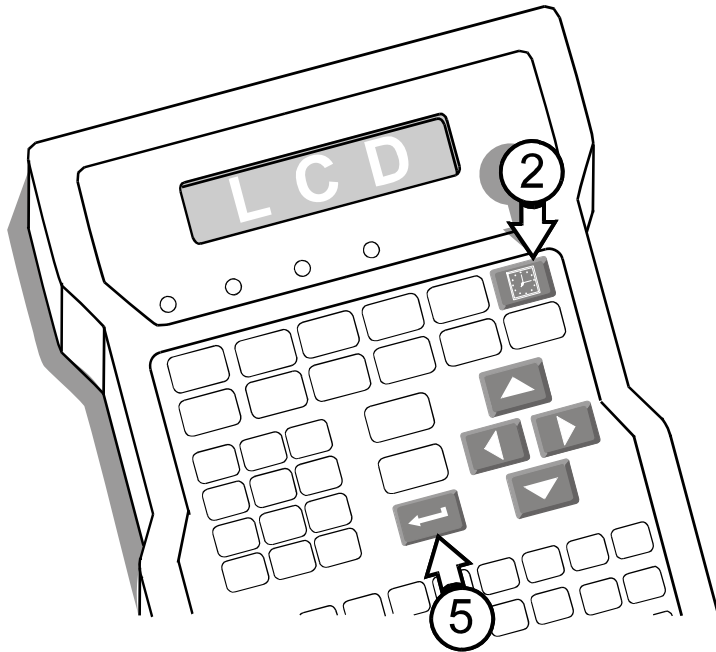

- 1 While editing, position the cursor where you want the time to appear.



- 2 Press TIME. The LCD will show the time enclosed by braces. The braces appear only on-screen, not in the printed message.

- 3 Position the cursor under the initial brace of the message time. The first line of the LCD will now show the format of the message time in an abbreviated form.

hh:mm {11:44} SHIPMENT

- 4 To change the time format, use the UP and DOWN ARROWS.



The chart below shows all the available time formats on the system with examples for 11:44 AM. All prompts with “hh” in them will display and print as a twenty-four hour clock.

Time in Message	Format Prompt	Explanation
{11:44}	hh:mm	Hours and minutes, 2 digits each separated by a colon.
{1}	1:AM/2:PM	1 = before 12 noon. 2 = after 12 noon.
{AM}	AM/PM	AM for before 12 noon. PM for after 12 noon.
{44}	mm	Minutes only in 2 digits.
{11}	hh	The hour only in 2 digits.
{11:44AM}	hh:mmAM/PM	Hours and minutes with AM or PM appended.
{1144}	hhmm	Hours and minutes with no separation.

- 5 Press ENTER when done.

This feature is a part of sample message G5.

Placing a Work Shift in a Message

E4

Review work instruction D4, “Setting Work Shifts” and D5, “Setting the Shift Start” before placing a work shift in a message.

You must be in the edit mode to place the work shift in a message. See Instruction A2, “Creating a Simple Message” to enter the edit mode.

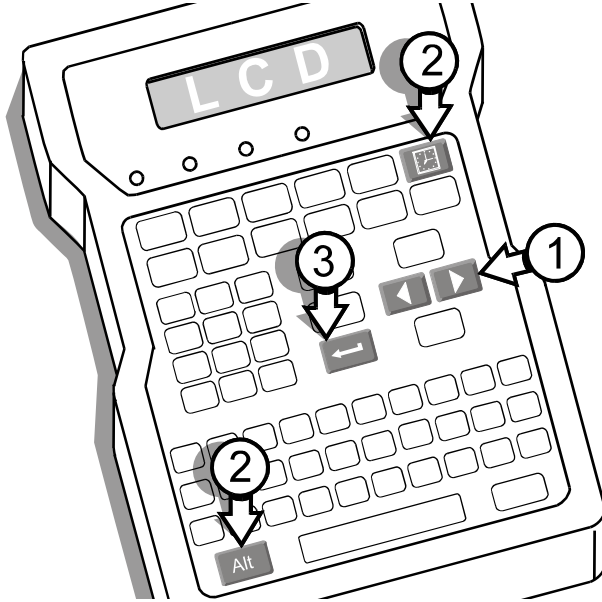

- 1 While editing, position the cursor where you want the work shift to appear.
- 2 Press ALT+TIME. The LCD will show the shift enclosed by braces. The braces appear only on-screen, not in the printed message.

```
SHIFT
{B} SHIPMENT
```

- 3 Press ENTER when finished.

Placing an Item Count in a Message

E5

Review work instruction D6, “Setting the Item Count” before inserting an item count into a message.

You must be in the edit mode to place the item count in a message. See Instruction A2, “Creating a Simple Message” to enter the edit mode.

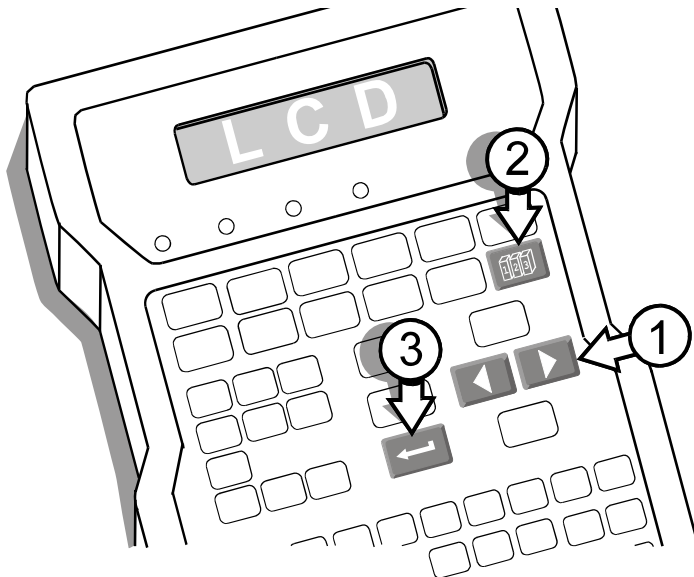

- 1 While editing, position the cursor where you want the item count to appear.
- 2 Press COUNT. The LCD will show the item count enclosed by braces. The braces appear only on-screen, not in the printed message. If you selected to print leading zeros (Instruction D6), then zeros will appear inside the braces.

```
COUNT 1, 2, 3
{1} SHIPMENT
```

- 3 Press ENTER when finished.

This feature is a part of sample message G2.

Placing a Pallet Count in a Message

E6

Review work instruction D7, “Setting a Pallet Count”, before inserting the pallet count into a message.

You must be in the edit mode to place the pallet count in a message. See Instruction A2, “Creating a Simple Message” to enter the edit mode.

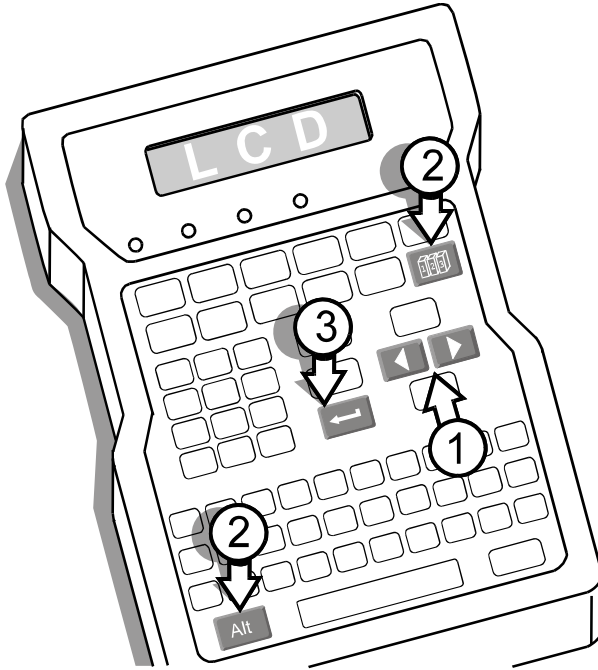

- 1 While editing, position the cursor where you want the pallet count to appear.



- 2 Press ALT+COUNT. The LCD will show the pallet count enclosed by braces. The braces appear only on-screen, not in the printed message. If you selected to print leading zeros (Instruction D7), then zeros will appear inside the braces. To verify that you have inserted the correct code, place the cursor on the initial brace. The type of code will appear in the first line of the LCD.

PALLET 10, 20, 30 [1] SHIPMENT

- 3 Press ENTER when finished.

This feature is a part of sample message G6.

Using Alternate Characters

E7

All alphabetic and numeric keys on the system keypad can display alternate characters when used with the up and down arrows. The English vowel set and the consonants C, N and Y have alternate characters with phonetic marks such as the umlaut (¨) and the acute accent (´). All consonant keys provide access to the entire alphabet in both uppercase and lowercase. The punctuation keys provide multiple punctuation marks. The instructions that follow explain how to access these characters.

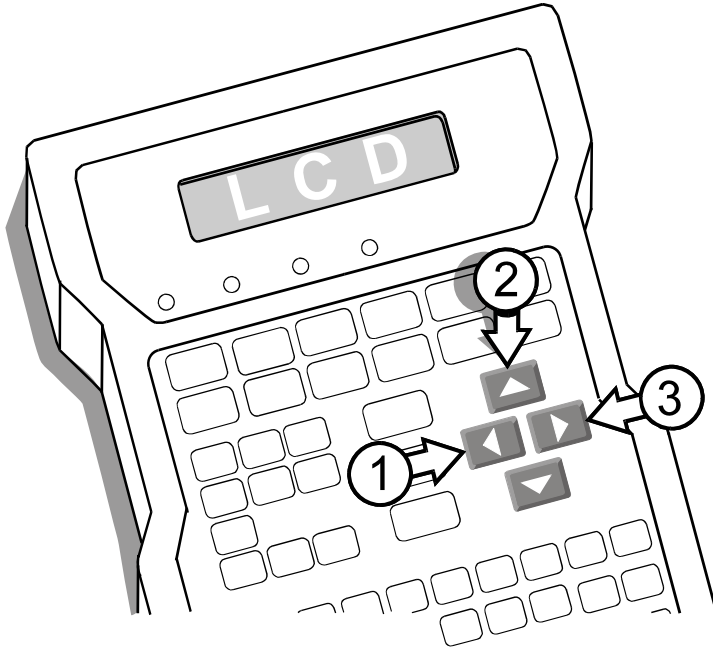

1 While editing or creating a message, type a letter and then place the cursor on it.

TESTING<

2 Press the up or down arrow and the LCD will show the alternate characters.

TESTING<

3 Press the right arrow when the character or mark you want appears onscreen.

The graphic below shows only some of the characters available. You can see all the characters by scrolling through each character on screen.

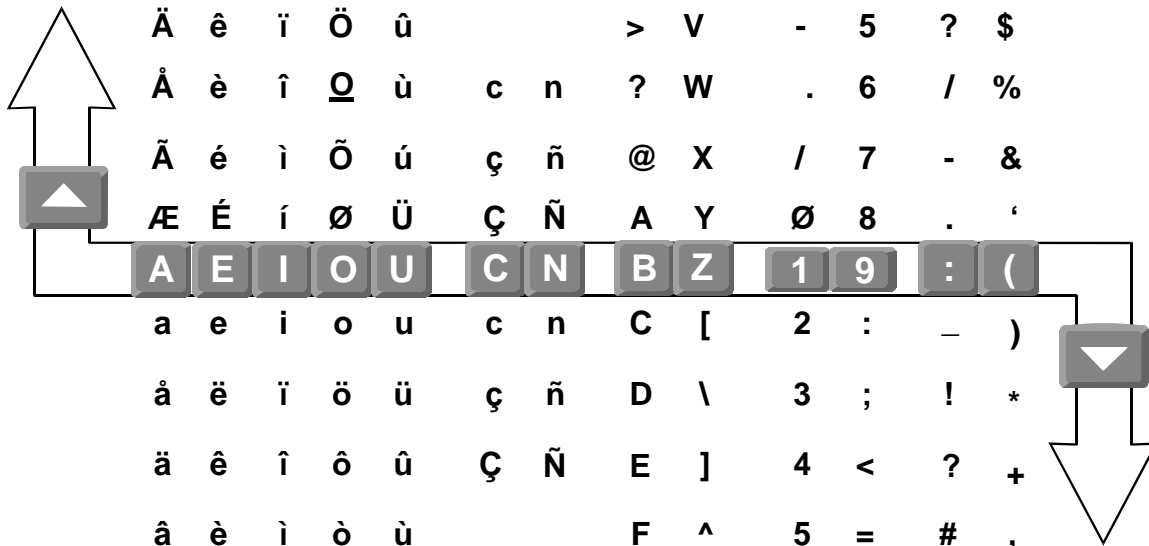

This feature is a part of sample message G4 and G5.

System Operation

F

Selecting a Language

F1

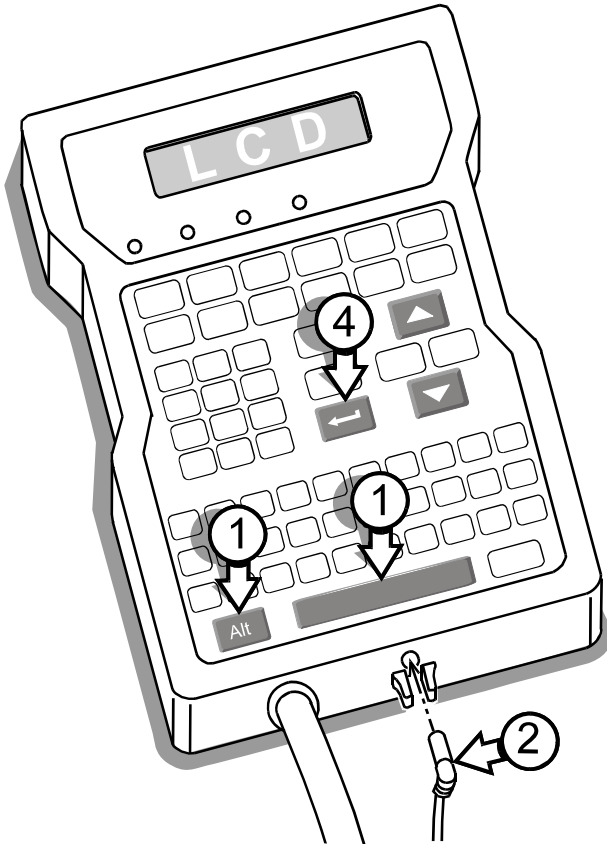

- 1 Press and hold ALT and SPACE.
- 2 Plug in the barrel connector.
- 3 Release the keys when the LCD shows "Self Test."

Self Test

- 4 Scroll to a language and press ENTER.



Language Choices:

1. English
2. Español
3. Deutsch
4. Français
5. Italiano
6. Nederlands

Setting the Date

F2

During Initialization

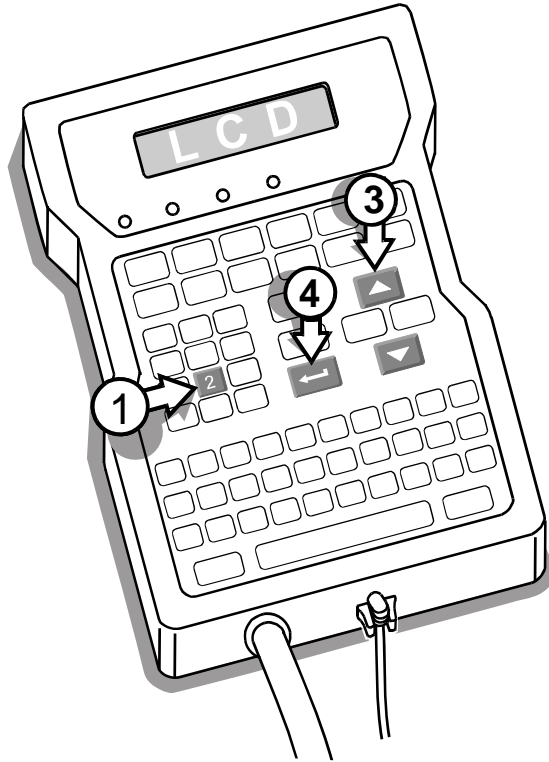

- 1 Press 2 when the LCD asks you to set the date.

Set Date		
1-No	2-Yes	:2

- 2 Move the cursor to the far right number in the year.

YYYY / MM / DD		
199	07	/ 07

- 3 Scroll to the correct year.

- 4 Press ENTER. The cursor will move to the Month field. Repeat steps 2 and 3 to alter the month and the day.

While Editing

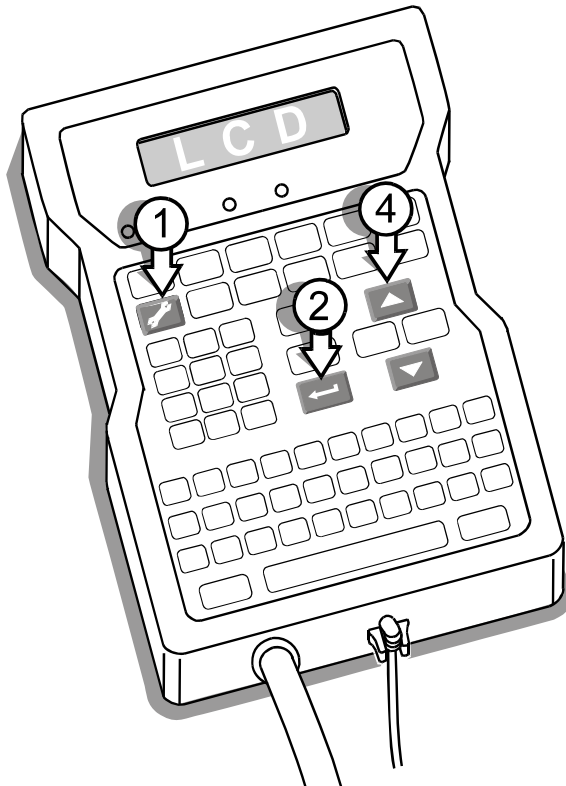

- 1 Press SET-UP.

Set-Up	
1-Date	↓

- 2 Press ENTER.

- 3 Move the cursor to the far right number in the year.

YYYY / MM / DD		
199	07	/ 07

- 4 Scroll to the correct year.



- 5 Press ENTER. The cursor will move to the Month field. Repeat steps 3 and 4 to alter the month and the day.

Setting Units of Measure

F3

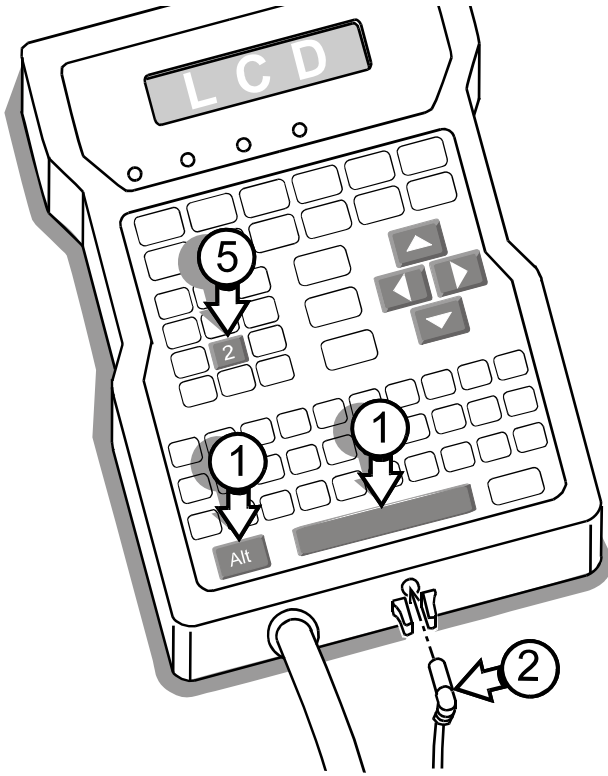

- 1 Press and hold ALT and SPACE.
- 2 Plug in the barrel connector.
- 3 Release the keys when the LCD shows "Self Test."

Self Test

- 4 Select a language, set the date and set the time (see Instruction F1).
- 5 Press 2 when the LCD prompts for units of measure.

Select Units
1-No 2-Yes :2

- 6 Press 1 for U.S. Customary or 2 for metric.

1-Inches 2:Meters
Units:1

Setting the Print Mode

F4

The system has two print modes: single and multiple. In Single mode (the default), it prints once on each item. In Multiple mode, it prints a single message multiple times on one item. Multiple mode is useful for printing repeated messages on long items such as sheets of wallboard. When you select to print multiple prints, the system will print until stopped by a photosensor signal.

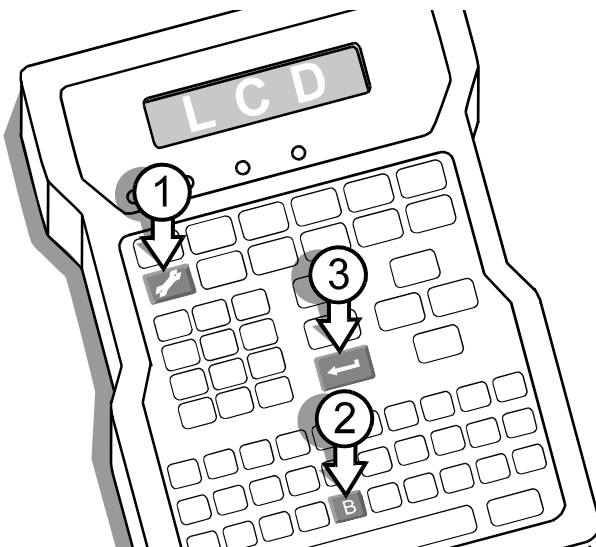

- 1 Press SET-UP.
- 2 Press B for Print Mode. The LCD will prompt for multiple prints.

Print Multiple
1-No 2-Yes :2

- 3 Make your choice and press ENTER. Either choice returns the display to the Set-Up menu.
- 4 If you choose multiple prints, you will need to define the distance between prints with Message Gap (see Instruction F5).

Setting the Message Gap

F5

Message Gap defines the distance between the beginning of each messages when printing the same message repeatedly on the same item.

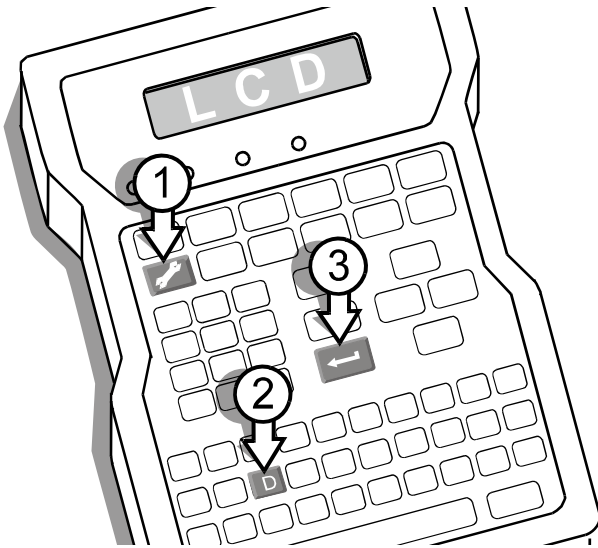

- 1 Press SET-UP.
- 2 Press D for "D-Message Gap."

Message Gap:
000.4 inches

- 3 Type the distance in inches or centimeters between messages and press ENTER.

Setting the Box Length

F6

The system has the ability to ignore photosensor signals after detecting the box. This feature is useful when you observe the system printing between boxes or more than once per box. Setting an accurate box length will prevent unwanted prints. Do not set the box length to be longer than the length of the product: you can miss printing on the next box if it is following too closely.

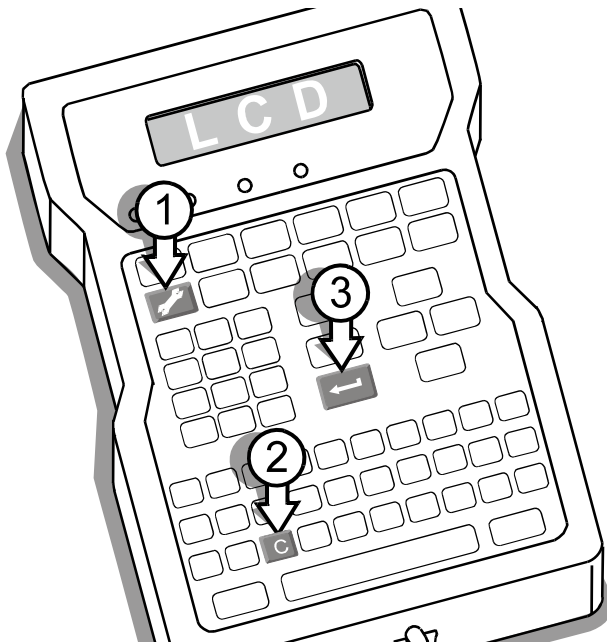

- 1 Press SET-UP.
- 2 Press C for "C-Box Length." The display will prompt for distance.

Box Length:
000.2 inches

- 3 Type in the box length in inches or centimeters.

Setting the Print Speed

F7

The system has the ability to print at a fixed speed while using the photosensors only to detect the arrival of a product, not to track the direction and speed of the product. Since the motion detection is off, fixed speed printing requires a fixed direction. Be sure to follow the directions on Instruction F8 to set the print direction. If the direction is not fixed, it is possible that your message will be unreadable.

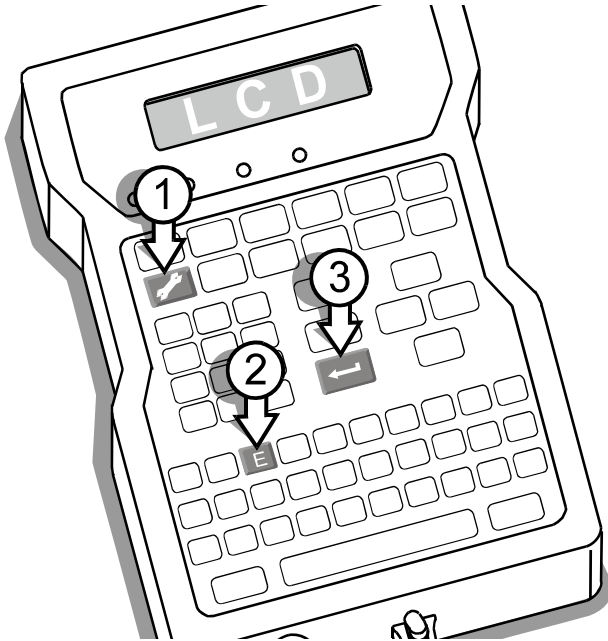

- 1 Press SET-UP.
- 2 Press E for “E-Print Speed.” The LCD will prompt for a Yes or No to fixed speed printing.

Fixed Speed (Y/N):		
1-No	2-Yes	:2

If you select “1-No”, the display will return to the Set-Up menu. If you select “2-Yes”, the LCD will ask for the speed in feet or meters per minute.

- 3 Type the speed and press ENTER.

Print Speed:
040.0 ft/min

Follow the directions in Instruction F8 to set the print direction.

Setting the Print Direction

F8

The system can print in the direction you choose. In normal mode, the photosensors detect the direction of the product and the controller adjusts the message to print correctly whether printing from left-to-right or from right-to-left. In fixed speed mode (Instruction F7) the message will still print in both directions but only one direction is correct: product moving in the other direction will receive a message printed backwards. To avoid backward printing, the direction of the printing must be fixed as well as the speed. The default direction is left-to-right.

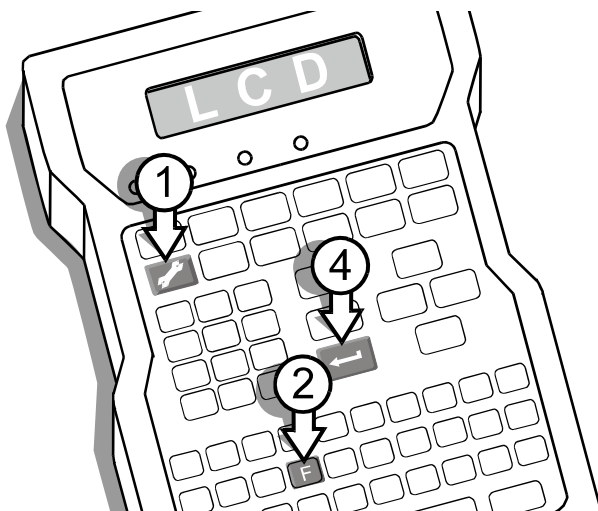

- 1 Press SET-UP.
- 2 Press F for “F-Print Direction.” The LCD will prompt for a Yes or No to fixed direction printing.

Fixed Direction (Y/N):		
1-No	2-Yes	:1

If you select “1-No”, the LCD will return to the Set-Up menu.

If you select “2-Yes”, the LCD will ask you to set the print direction:

Fixed Direction		
1:-←	2:→	:2

- 3 Select a direction and press ENTER.

Using a Password

F9

The system can operate with password protection and lock out all functions except printing, purging and access to information.

When password protected, the screen will report "Invalid Password" whenever it receives an incorrect password. If you make a mistake during password entry, press ENTER and wait. The screen will refuse your entry, report "Invalid", wait 3 seconds and give you another chance. It will repeat this cycle until it receives the active password.

Valid passwords contain only alphabetic characters. Passwords CANNOT CONTAIN numbers, punctuation marks, icon key entries or scrolled (alternate) characters.

Accessing the Password Feature

- 1** Press SET-UP.
- 2** Press H. The Password menu offers three choices: 1. Enable; 2. Disable; and 3. Change.

Password
1-Password Enable

Password
2-Password Disable

Password
3-Change

Enabling Password Protection

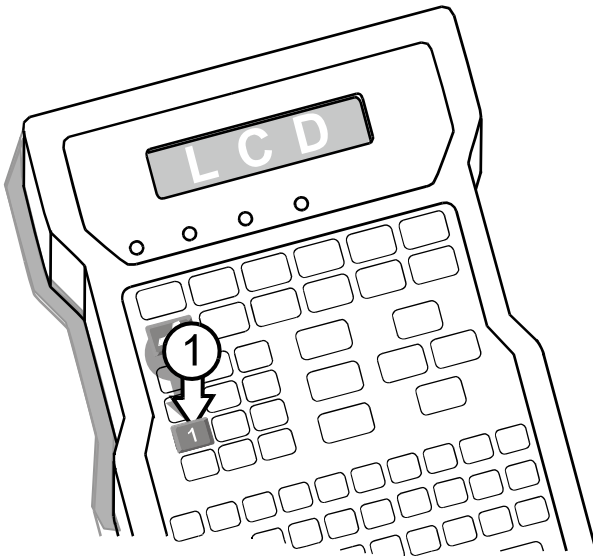

- 1** Press 1. The LCD will prompt "PASSWORD" and show a blank second line.

Password

- 2** To enable password protection for the first time, type **ADMIN** and press ENTER.

Password

If you type ADMIN correctly, the screen will respond with "OK." Your printer is now protected and will allow access only to Information, Print and Purge. All other functions now require password entry.

Using a Password

continued **F9**

To enable password protection after changing to a password other than ADMIN, you must enter the new password when prompted for "PASSWORD." If you type the new password correctly, the screen will respond with "OK."

Disabling Password Protection

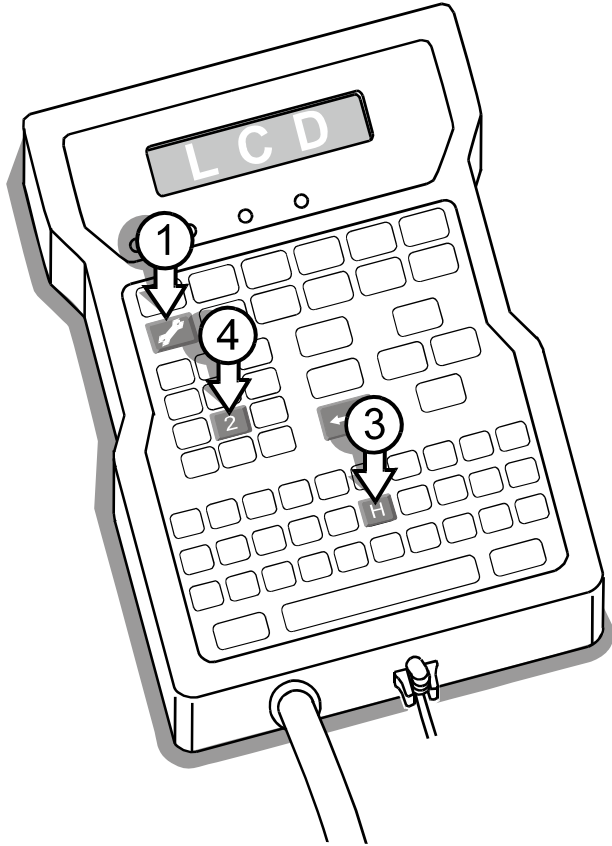

1 Press SET-UP.

2 Type the current password.

Password

3 Press H to access the Password menu.

Password
2-Password Disable

4 Press 2. The LCD will respond "Disabling Password..."

All functions are now accessible without password entry.

Using a Password

continued F9

Changing a Password

NOTE: You can change the password when password protection is disabled. If you do, record the new password where you can find it easily because when the time comes to enable password protection, the system will no longer accept ADMIN as the password.

Changing when Protection is Disabled

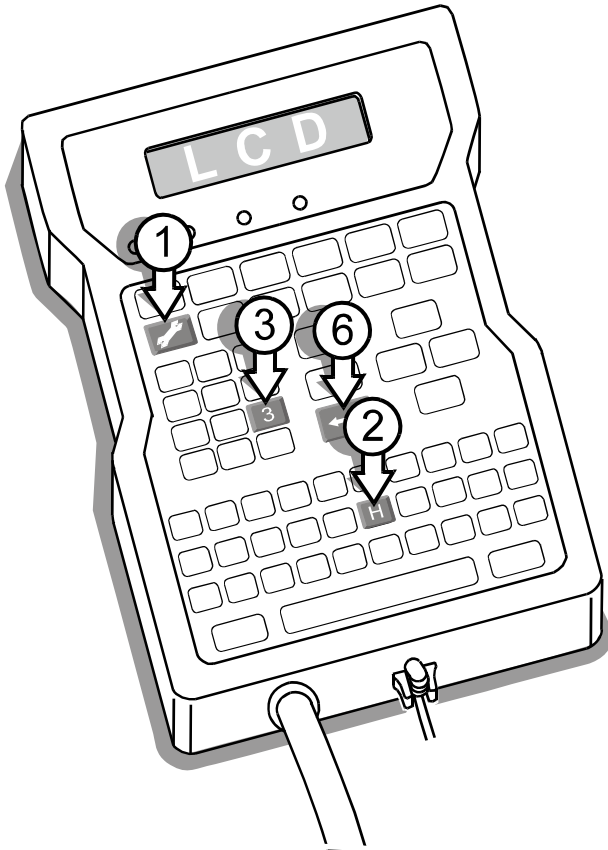

- 1** Press SET-UP.
- 2** Press H to access the Password menu.

Password
1-Password Enable
- 3** Press 3 to select "Change Password".

Password
3-Change
- 4** The LCD will respond with "Old Password" and a blank line. Type the current password and press ENTER. If correct, the screen will respond with "Old Password, OK" and request "New Password."
- 5** Type a new password. Note that no scrolled characters, numbers or punctuation marks will be accepted.

- 6** Press ENTER. The LCD will prompt "Confirm Password."
- 7** Type your new password exactly as you typed it before and press ENTER. If you vary your spelling, the LCD will respond "New Password" and you must redefine the new password. When you have entered your password successfully two times, the screen will return to the password menu.

Using a Password

continued **F9**

Changing when Protection is Enabled

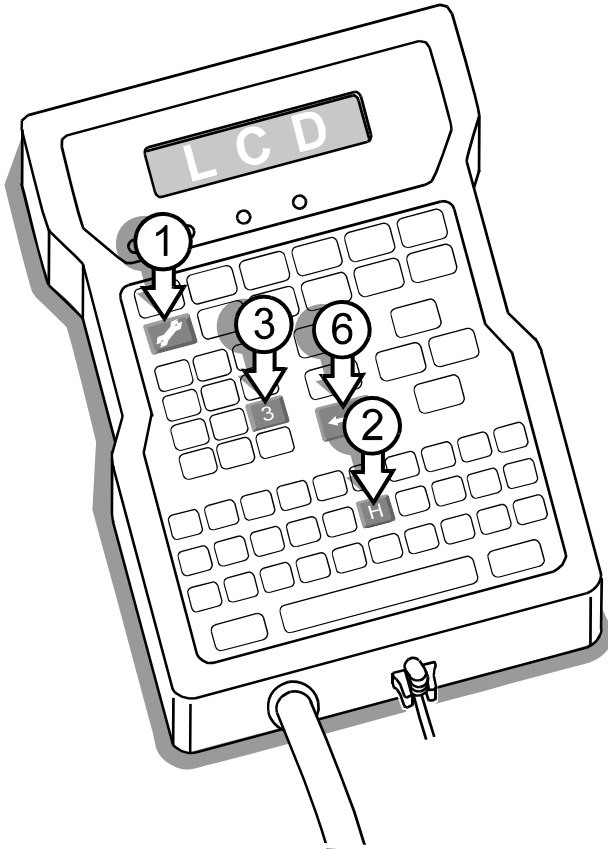

- 1** Press SET-UP and type the current password. Press ENTER.
- 2** Press H to access the Password menu.

Password
1-Password Enable

- 3** Press 3 to select "Change Password".

Password
3-Change

- 4** The LCD will respond with "Old Password" and show a blank line.

Old Password

Type the current password and press ENTER. If correct, the screen will respond with "OK" and request "New Password."

- 5** Type a new password and press ENTER. The screen will prompt "Confirm Password."
- 6** Type your new password exactly as you typed it before and press ENTER. When the LCD reports "OK", you have successfully changed the password.

Using the External Photocell Model

F10

These instructions cover the configuration of the system with the external photosensor.

Setting the controller for the external photosensor requires accessing a menu that is available only after a special initialization. **DO NOT USE THIS MENU** option if you are using the standard system and its built-in photosensors. Start by unplugging the system.

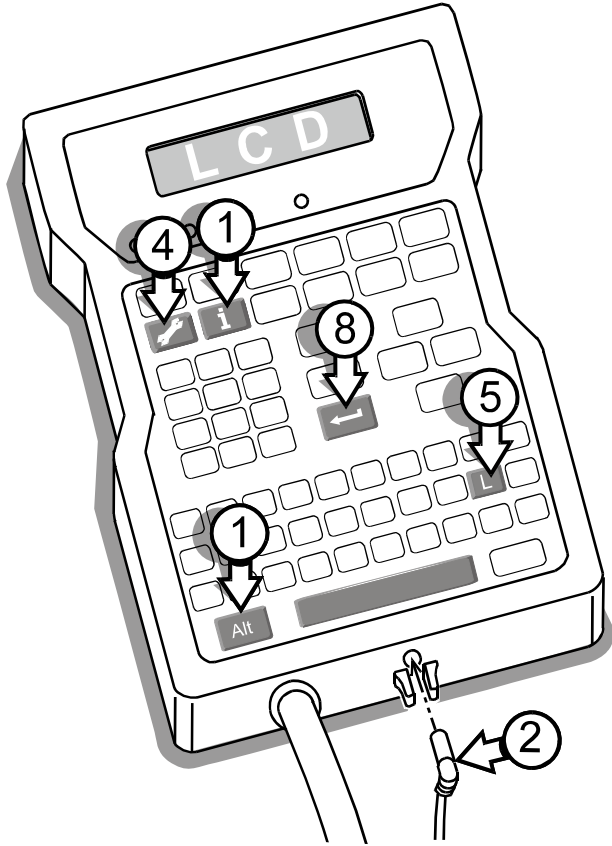

- 1** Press and hold ALT + INFORMATION.
- 2** Plug in the cannon connector.
- 3** Release the keys when the LCD shows "Information".

Information 1-Unused Messages
--

- 4** Press SET-UP.
- 5** Press L on the QWERTY keypad. The LCD will prompt for an external photocell.

External Photocell? 1-No 2-Yes :1
--

- 6** Press 2 and the LCD will prompt for a fixed print speed.

Print Speed: 040.0 ft/min
--

- 7** Type in a print speed and the LCD will prompt for a fixed print direction.

Fixed Direction: 1:<--- 2:---> :2
--

- 8** Select the print direction and press ENTER.

Sample Messages

G

New Message

G1

Message

2000 PRODUCTS IN 2000

Goal

Create a new message on the system.

Instructions

Naming a message: A2

Adding text to a message: A2

Saving a message: A2, A3

Retrieving a message: A1, A3

1. Press EDIT to select a new message.



1-New Message
2-Edit Message

2. Press 1 to start a new message.



Name:
<

3. Type 2Y2 to name the message.

Name:
2Y2<

4. Press ENTER to access the message editor.



Editing...
<

5. Type 2000 PRODUCTS IN 2000.

Use the LEFT and RIGHT ARROW to see the entire message.



Editing...
2000 PRODUCTS IN 200<

6. Press ENTER to complete the message.



Editing...
2000 PRODUCTS IN 200<

7. Press 1 to save the message.



1-Save: 2Y2
2-Cancel Changes: 2↓<

Message with Date and Count

G2

Before starting, follow the directions in Instruction D1, “Setting the Date”, and D6, “Setting the Item Count”.

Message

158/2

Goal

Create a message with the current date and the product count.

Instructions

Naming a message: A2

Changing the Date Format: E1

Adding text to a message: A2

Placing the Item Count: E5

Saving a message: A2, A3

Placing the Date: E1

1. Press EDIT to select a new message.



1-New Message
2-Edit Message

2. Press 1 to start a new message.



Name:
<

3. Type DATECOUNT to name the message. Press ENTER.



Name:
DATECOUNT<

4. Press DATE.



Editing...
{06/07/99}<<

5. Move the cursor under the first brace.



MM/DD/YY
{06/07/99

6. Scroll until the first line shows DDD, the day in three digits (Julian date).



DDD
{158}

7. Move the cursor to the end of the message.



Editing...
{158}

Message with Date and Count

continued G2

8. Press SLASH.



Editing...
{158}

9. Press COUNT.



Editing...
{158}/{1}

10. Press ENTER to complete the message.



1-Save:DATECOUNT
2-Cancel Changes:D↓

11. Press 1 to save the message.



1-New Message
2-Edit Message

12. Run sample prints to see the count increase in each message.

Message with Expiration Date

G3

Before starting, follow the directions in Instructions D1, "Setting the Date", and D2, "Setting the Expiration Date."

Message

USE BY: AUG 99

Goal

Create a message with an expiration date.

Instructions

Naming a message: A2

Adding text to a message: A2

Saving a message: A2, A3

Inserting an expiration date: E2

1. Press EDIT to select a new message.



1-New Message
2-Edit Message

2. Press 1 to start a new message.



Name:
<

3. Type USEBY to name the message.

Name:
USEBY<

4. Press ENTER to access the message editor.



Editing...
<

Message with Expiration Date

continued G3

5. Type **USE BY**:

Editing...
USE BY: []

6. Press ALT+DATE.



Expiration Days
0000<

7. Type in the number days when the product expires and press ENTER.

Example: Enter **0030** for thirty days.

Editing...
USE BY: {08/04/99} []

8. Move the cursor under the first brace and scroll until the XMON YY prompt appears on the first line of the LCD.



XMON YY
USE BY: [] {AUG 99}<

9. Press **ENTER** to complete the message.



1-Save:USEBY
2-Cancel Changes: U↓

10. Press **1** to save the message.



1-New Message
2-Edit Message

Message with Alternate Characters

G4

Message

GRÜN BEANS- NT WT 20 lbs

Goal

Create a long message with alternate characters.

Instructions

Naming a message: A2

Adding text to a message: A2

Saving a message: A2, A3

Using alternate characters: E7

1. Press EDIT to select a new message.



1-New Message
2-Edit Message

2. Press 1 to start a new message.



Name:
<

Message with Alternate Characters

continued G4

3. Type **GB** to name the message.

Name:
GB<

4. Press ENTER to access the message editor.



Editing...
<

5. Type **GRU**.

Editing...
GRU

6. Move the cursor under the U and scroll up until the U-umlaut (ü) character appears.



Editing...
GRÜ<

7. Move the cursor to the right and type **N BEANS:**



Editing...
GRÜN BEANS:

8. Move the cursor under the colon (:) and scroll up until the hyphen (-) appears.



Editing...
GRÜN BEANS:

9. Move the cursor to the right and type **NT WT 20 LBS.**



Editing...
BEANS-NT WT 20 LBS

10. Move the cursor under the colon the L and scroll down until the lowercase l appears.

Move the cursor under the B and scroll down until the lowercase b appears.

Move under the S and scroll down until the lowercase s appears.

Editing...
BEANS-NT WT 20 lbs

11. Press **ENTER** to complete the message.



1-Save:GB
2-Cancel Changes: G↓

12. Press **1** to save the message.



1-New Message
2-Edit Message

Wide Message with Time Mark

G5

Before starting, review Instructions D3, “Setting the Time”, and C3, “Adjusting the Character Width”.

Message 11:44 AM

Goal *Create a message with wide characters that tells the time of printing.*

Instructions

- Naming a message: A2*
- Adding text to a message: A2*
- Saving a message: A2, A3*
- Using alternate characters: E7*
- Adjusting character widths: C3*

1. Press EDIT to select a new message.



1-New Message
2-Edit Message

2. Press 1 to start a new message.



Name:
<

3. Type **WTIME** to name the message.

Name:
WTIME<

4. Press ENTER to access the message editor.



Editing...
<

5. Press TIME.



Editing...
{11:44}<

6. Move the cursor under the first brace ({}) and scroll up until hh:mmAM/PM appears in the top line of the LCD.

hh:mmAM/PM
{11:44AM}<

7. Press CHARACTER WIDTH and scroll down to 6.



Set Character Width
6

8. Press ENTER twice to complete the message.



1-Save:WTIME
2-Cancel Changes: W↓

Message with Pallet and Item Count

G6

Before starting, follow the directions on instructions D6, “Setting the Item Count”, and D7, “Setting the Pallet Count”. Select YES for leading zeros when setting up the Item Count and NO for the pallet count.

Message **APPLES 2/0000001**

Goal *Create a message with a pallet count and an item count with leading zeros.*

Instructions *Naming a message: A2* *Placing the Item Count: E5*
 Adding text to a message: A2 *Placing a Pallet Count: E6*
 Saving a message: A2, A3

1. Press EDIT to select a new message.



1-New Message
2-Edit Message

2. Press 1 to start a new message.



Name:
<

3. Type **APPLES** to name the message. Press ENTER.



Name:
APPLES<

4. Type **APPLES** for the message text and press SPACE.

Editing...
APPLES

5. Press ALT + COUNT to insert the Pallet Count.



Editing...
APPLES {1}

6. Move the cursor to the initial brace to confirm that the code in the message is the Pallet Count code.



PALLET 10, 20, 30...
APPLES {1}

7. Move the cursor to the end of the message.



Editing...
APPLES {1}<

Message with Pallet and Item Count

continued G6

8. Press SLASH.



Editing...
APPLES {1}/

9. Press COUNT.



Editing...
APPLES {1}/{0000001}

10. Move the cursor to the initial brace to confirm that the code in the message is the Item Count code.



COUNT 1,2,3
APPLES {1}/0000001<

11. Press ENTER to complete the message.



1-Save:APPLES
2-Cancel Changes:A↓

12. Press 1 to save the message.



1-New Message
2-Edit Message

13. Press PRINT and then 1 to print this message.



Name:APPLES
APPLES {1}/0000001

14. Press ENTER and the LCD will show the next count in the sequence of pallets. Press 2 to change the pallet count.



Pallet Count=0000001
1-OK 2-Change :█

15. The LCD will prompt for a different pallet count. Move the cursor to the right and type 2.



Pallet Count
000000█

16. Press ENTER and the LCD will prompt for the box number on the pallet. Press 2 to change.



Box # 1 of 12
1-OK 2-Change :█

Message with Pallet and Item Count

continued G6

17. Press ENTER and the LCD will prompt for a box number change.
Press ENTER again.



Set Box #
01 of 12

18. The LCD will show the next item count it will print in the APPLES message and offer you the opportunity to change that count. Press 2.



Item Count=0000001
1-OK 2-Change :1

19. The LCD will show the screen for changing the Item count.
Press ENTER to start printing.



Item Count
0000001

Troubleshooting

H

NOTE: This section is intended for qualified maintenance personnel.

Problems with the printer are separated into two areas: Either the unit is not printing or the unit is printing but the results are unsatisfactory.

Not Printing, Questions and Solutions

H1

NOTE: Procedures in this section are intended for qualified maintenance personnel.

Q1 The system is not printing and the power LED is not lighted. Why?

- S1 The printer does not have power. Check the following:
- [1] The round plug connection at the base of the controller;
 - [2] The cable connection at the base of the power supply;
 - [3] The round plug for a 15 VDC output;
 - [4] The cable connection at the rear of the printhead;
 - [5] The wall receptacle to make sure that it is supplying power.

Q2 The system is not printing and the photocell LED is not blinking. Why?

- S2 The photosensors can not detect the product. They can be either too far from the product or dirty. Clean the photosensors and adjust the printhead within 0.25 inch of the product.

Q3 The system is not printing and the ink LED is flashing. Why?

- S3 The printer is out of ink. Replace the old ink can with a new can.

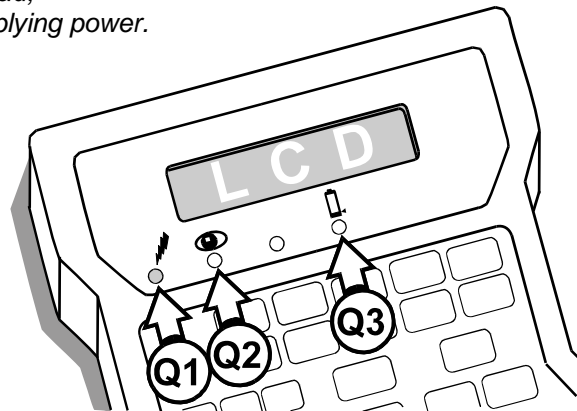

Q4 The system is not printing but all LED signals are normal. Why?

- S4 The character width setting is too small for the product line speed. Increase the character width by following the directions in Instruction C3.

Q5 The system is not printing and ALL the LEDs are blinking. Why?

- S5 A short-circuit has occurred. Disconnect the round controller power connector, and the printhead. Connect the round controller power connector, but DO NOT connect the printhead. If the unit initializes normally, replace the printhead. If the unit does not initialize normally, replace the controller.

Unsatisfactory Print, Questions and Solutions

H2



Q6 The system is not printing even though all of the LEDs are working normally.

S6 *Disconnect power and remove the four Phillips screws from the controller housing, and check the cable connection between the printhead cable and the controller board. Reassemble and reconnect power.*

Q7 All indications are normal but the system prints on every other box. Why?

S7 *The Box Length distance is longer than the length of the product. Decrease the Photocell Off distance by following the directions Instruction F6.*

Q8 The system is printing normally but it's the wrong message. Why?

S8 *The wrong message has been selected to print. Follow the directions in Instruction A1 and select another message to print.*

Q9 The system is printing the correct message but the message is too far to one side. Why?

S9 *The message indent distance is incorrect. Adjust the distance by following the directions in Instructions C1 and C2.*

Q10 The system is printing normally but the message is too wide. Why?

S10 *The character width is too big or too narrow. Perform one of the following procedures:*

[1] *Shorten or widen the character width by following the directions in Instruction C3.*

[2] *Increase or decrease the fixed speed by following the directions in Instruction F7.*

Q11 The system is printing the correct message but ink dots are missing from some of the characters. Why?



S11 *The faceplate of the printhead is dirty and some of ink jet orifices are blocked. Clean the faceplate with Maintenance Spray and purge the printhead. If any of the ink jet orifices remain blocked, then remove the obstruction using a Broach Kit (1902-857).*

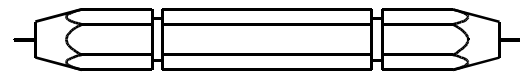

1902-857

Q12 The system is printing the correct message but the ink dots are too small. Why?

S12 *The dot size is too small. Increase the dot size by following the directions in Instruction C5.*

Q13 The system is printing the correct message but the characters are out of position and there are a lot of extra dots. Why?

S13 *The printhead is too far from the product. Adjust the printhead until it is closer to the box. The faster the box travels the closer the printhead must be to the box.*



Q14 After sitting idle for a few minutes, the dots in the in the first message are too small when the system starts printing again. Why?

S14 *Undersized dots on startup can result from two adjustments: dot size and print delay. These variables need to be tested and set at the same time to achieve a satisfactory solution. Adjust the size of the first printed dots and the print delay by following the directions in Instruction C10.*

Q15 I selected fixed speed and now my system prints random dots. Why?

S15 *The print direction is wrong. Change the print direction by following the directions in Instruction F8.*

Unsatisfactory Print, Questions and Solutions

continued H2

Q16 The system is printing the correct message, but the ink dot size is fluctuating from small to large. Why?



S16 If print dot size is fluctuating, check the printhead pressure using a pressure gauge (5700-743). If a pressure gauge is not available, refer to Section H6: Alternate Method of Performing the Regulator Maintenance Procedure without a Pressure Gauge. If the dot size fluctuations can be correlated to changes in ink pressure, the ink regulator may be in need of service.

Printhead Leaking, Questions and Solutions

H3

Q1 The printhead is leaking ink from the faceplate when not printing. Why?

S1a The ink regulator pressure may need to be adjusted. Variations in ink pressure produce different dot sizes; the higher the pressure the larger the dot. However, over-pressurizing the printhead can result in leakage or cause ink to shoot across the conveyor. Follow the instructions listed in Section H5: Ink Regulator Maintenance Procedure.

S1b The printhead may need solenoid adjustment. Follow the instructions listed in Section H4: Printhead Preload Adjustment Procedure.

Q2 The printhead is leaking ink from the faceplate while printing. Why?

S2a The ink regulator pressure may need to be adjusted. Variations in ink pressure produce different dot sizes; the higher the pressure the larger the dot. However, under-pressurizing the printhead can cause ink to drip from the front plate while printing. The printhead may also take a long time to print all the dots at morning startup. Follow the instructions listed in Section H5: Ink Regulator Maintenance Procedure.

S2b The printhead may need solenoid adjustment. Follow the instructions listed in Section H4: Printhead Preload Adjustment Procedure.

Printhead Preload Adjustment

H4

If a printhead is leaking when not printing, it may require solenoid preload adjustment.

Preload is the amount of force a piston [H] applies to the membrane [D] to prevent ink from leaking when the printhead is idle or not printing.

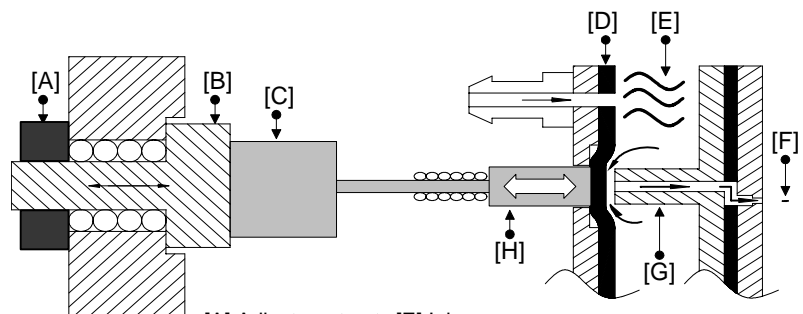

- | | |
|--------------------|------------------------|
| [A] Adjustment nut | [E] Ink |
| [B] Bushing | [F] Ink droplet |
| [C] Solenoid | [G] Chamber plate post |
| [D] Membrane | [H] Piston |

Printhead Preload Adjustment

continued H4



- 1 Adjust the regulator to the preload pressure (9 psig).
- 2 Clean the front plate with a clean cloth and maintenance spray.
- 3 Remove the printhead cover.
- 4 Purge the printhead.
- 5 Clean the front plate with a clean cloth and maintenance spray.
- 6 Identify the orifice that is leaking from the illustration at right.

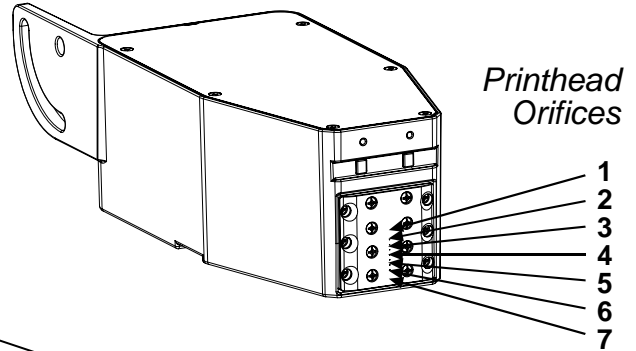

- 7 Use the diagram at right to locate the corresponding adjustment nut for the leaking orifice.

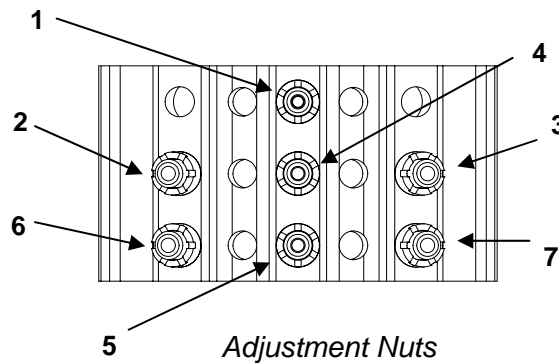

- 8 Using the preload adjustment tool, **SLOWLY AND CAREFULLY** turn the adjustment nut **COUNTERCLOCKWISE** approximately 1/8 turn to ADD additional pressure to the piston.



CAUTION: Excessive preload will damage the printhead.

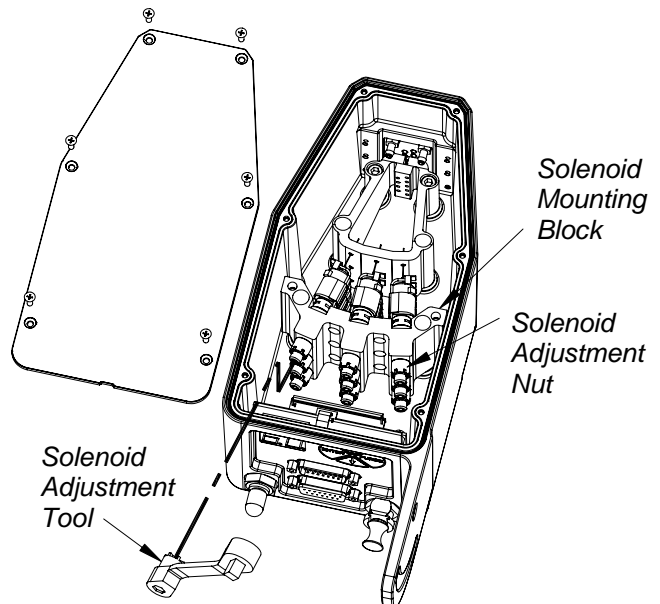

- 9 Purge the printhead.
- 10 Clean the front plate again with a clean wipe and maintenance spray.
- 11 If no static leakage is observed, replace the printhead cover. If the printhead continues to leak, repeat the adjustment procedure.
- 12 Adjust the regulator to the operating pressure (7 psig).

Ink Regulator Maintenance Procedure

H5

Pressure swings (decreasing and increasing pressure from nominal setting) can be caused by obstructions in the valve seat of the ink regulator. Obstructions in the valve seat area may also cause the pressure to creep up over a period of time (for example, the pressure is set at 7 PSIG, and fifteen minutes later it has increased to 9 PSIG).



The following maintenance procedure can remove obstructions from the valve seat area of the ink regulator, restoring normal operation.

- 1** Ensure that the system is idle and not in print mode.
- 2** Install a NEW can of conditioner into the receiver (ink may be used, but conditioner is preferred).
- 3** Unplug the ink line from the printhead.
- 4** Plug the ink line into an effluent bottle (5750-503).
- 5** Remove the regulator adjustment locking screw, and pull the pressure adjustment knob into the unlocked position.
- 6** Rotate the pressure adjustment knob clockwise until it stops, then counterclockwise until it stops. Repeat six to twelve times.
- 7** Disconnect the ink line from the effluent bottle and re-connect it to the printhead.
- 8** Turn the ink regulator off (completely counter-clockwise).

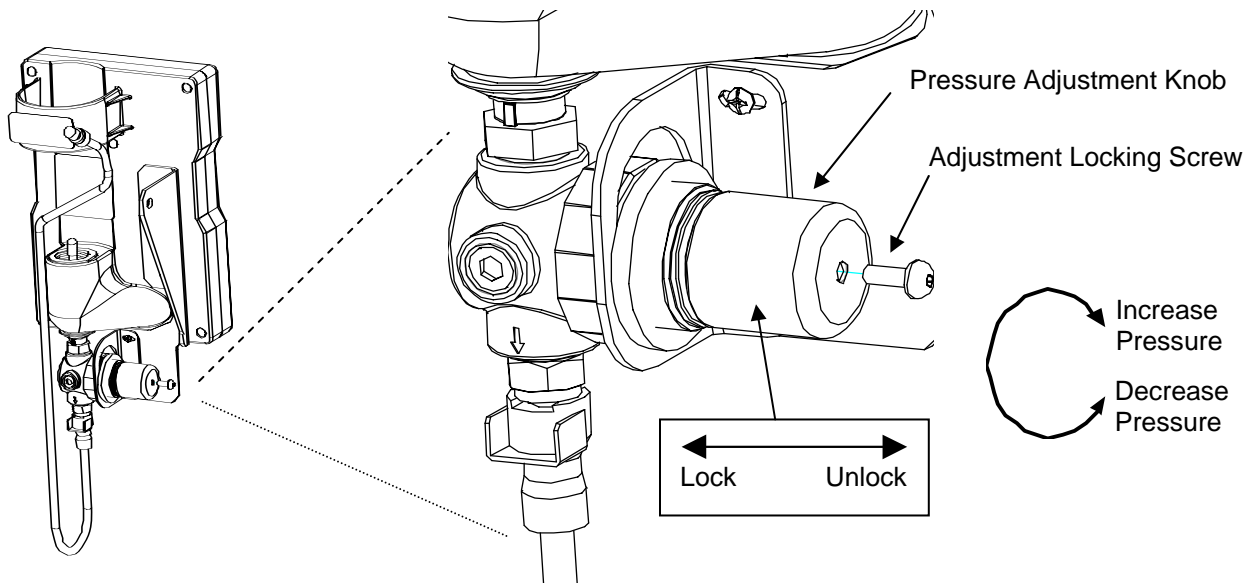

- 9** Attach a pressure gauge to the ink outlet (male quick-disconnect). The gauge must be level with the printhead for accurate measurements.
- 10** Increase the regulator to 7psi (nominal operating pressure).

NOTE: The ink regulator pressure setting should always be adjusted by turning the pressure adjustment knob clockwise (increasing pressure). Never set the regulator pressure by turning the knob counterclockwise (decreasing pressure). If the regulator was adjusted above desired setting, turn the regulator knob fully counterclockwise until it stops and purge the printhead to relieve internal pressure. Then, slowly open the regulator by turning it clockwise until the desired pressure has been achieved.

Ink Regulator Maintenance Procedure**continued H5**

- 11** Purge the printhead three times.
- 12** Check the pressure reading indicated on the gauge. The pressure should not deviate more than .50 PSIG from the set pressure. If the deviation is more than .50 PSIG, reset the pressure per steps 10 through 13.
- 13** Disconnect the pressure gauge.
- 14** Push the adjustment knob into the locked position.
- 15** Reinstall the adjustment locking screw. (Recommended torque = 16in-lbs.)



CAUTION: Observe the following precautions while using and cleaning the ink pressure gauge:

- 1** Do not probe into the pressure gauge with objects when cleaning. Use the appropriate conditioner and brush.
- 2** Pressure measurements are relative to the height from which they are measured. When measuring printhead pressure, the gauge must be at the same height as the printhead.
- 3** Do not leave the gauge hanging from the printhead connection for very long. Its weight will fatigue the fitting, eventually breaking it off and allowing pressurized ink to flow freely from the head.
- 4** The gauge should be calibrated periodically for accuracy. This should be done at least once per year, or whenever it has been dropped.

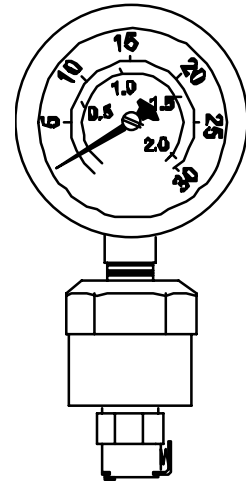

System Specifications

Appendix A

Controller/Ink Delivery System

Appendix A1

Weight	Controller and IDS (no bracketry or ink) 3.5 lbs. (1.6 kg)
Microprocessor	32-bit CMOS 68332
LCD	European display: 20 characters, 5 x 8 matrix, European character set Asian display: 20 characters, 5 x 8 matrix, Japanese character set
LED	Four status – Low Ink, Printing, Power and Photosensor
Keypad	Twelve special function keys; numeric keypad; QWERTY array with ALT key combinations for multiple character sets; four keys for cursor control.
Message Storage	Ninety-nine 50-character messages
Languages	European: English, French, German, Italian, Spanish Asian: English and selected Katakana & Kanji characters
Enclosure	Injection molded thermoplastic
Ink Capacity	Can, 13.5 fluid ounces (400 ml.)
Electrical	Power Supply Input : 100V – 240V, 0.7A 50/60 Hz
Dimensions	8.75 in x 6.25 in x 3.25 in (222 mm x 159 mm x 83 mm)

Printhead

Appendix A2

Weight	5.4 lbs (2.4 Kg)
Resolution	7 dots/inch vertical, 12 dots/inch horizontal
Dot Dia. Range	0.050-0.100 in (1.27 – 2.54 mm)
Rec. Throw Distance	1/2-in max. at 50 ft/min; 12.7 mm at 15.24 m/min 3/8-in max at 150 ft/min; 1.59 mm at >45.72 m/min
Max. Line Speed	250 ft/min (76.2 m/min)
Character Height	5/8 in (15 mm) 7 dot 3/8 in (10 mm) 5 dot
Ink Colors	Black, red, green, blue, yellow, orange
Operating Pressure	7 psi (.48 bar)
Operating Temperature	40° to 110° F (4.4° to 43.3° C)
Photosensors	Two with up to .50 in max. read distance
Regulator Output Pressure Setting (Normal Operating)	7 psi (.48 bar) (With 50 psi input pressure)
Ink Compatibility	Inks are water-based and non-flammable
Ink Compliance	These inks meet CONEG legislation for printing onto packaging components. All components of these inks are included in the United States TSCA and European EINECS inventories of existing chemical substances.
Dimensions	4.45 in x 3.33 in x 11.45 in
System Safety	TUV GS CE (UL/EN 60950)
Options	External photosensor available.

Parts and Supplies**Appendix B****Service Parts Kits****Appendix B1**

(See illustration on following page.)

Description	Water-Based Porous	Alcohol-Based Non-Porous
Printhead Replacement Kit	5770-202P	5770-202NP
Controller, Domestic/European	5750-430	5750-556
Controller, Domestic/European with External Photocell (not shown)	5750-431	5750-552
Controller, Domestic/Asian	5750-432	5750-553
Ink Delivery System Kit	5750-434	5750-557
Ink Line Replacement Kit	5750-563	5750-563
Broach Kit	1902-857	1902-857
Broach Refills	1901-563	1901-563
Wipes, Lint-Free	6600-171	6600-171
Power Supply	5750-113	5750-113
CPU Board, Domestic/European	5750-208E	5750-208E
CPU Board, Domestic/Asian	5750-208A	5750-208A
Effluent Bottle	5750-503	5750-503
Firmware, Domestic/European	5750-117	5750-117
Firmware, Domestic/Asian	5750-118	5750-118
Keypad Assembly, Domestic/European	5750-209E	5750-209E
Keypad Assembly, Domestic/Asian	5750-209A	5750-209A
LCD Display, Domestic/European	5750-053	5750-053
LCD Display, Domestic/Asian	5750-061	5750-061
Preload Adjustment Tool	5770-201	5770-201
Printhead Internal Tubing Kit	5770-205	5770-205
Printhead PCB Replacement	5770-204	5770-204

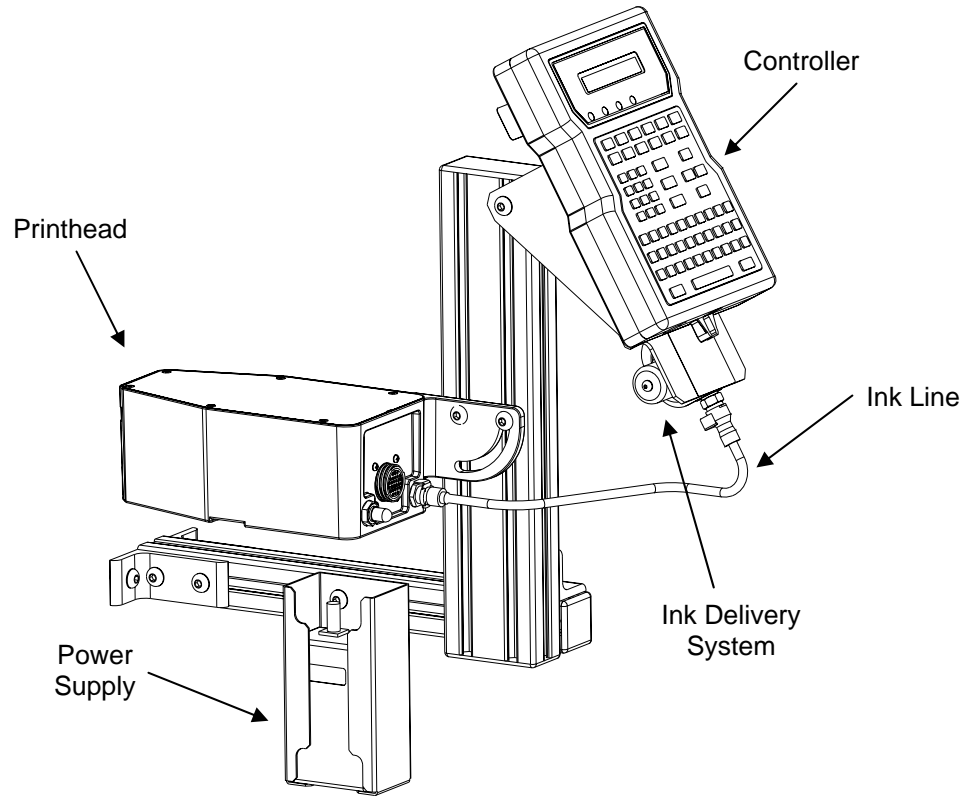

Consumables

Appendix B2

Water-Based for Porous Ink Jet Systems:

Product	Part Number	Package
Conditioner, TWP	5750-242	2/case
Ink, TWP-101 Black	5750-243	6/case
Ink, TWP-4 Blue	5750-245	6/case
Ink, TWP-3 Green	5750-246	6/case
Ink, TWP-2 Red	5750-244	6/case
Maintenance Spray, TWP	5750-249	2/case

Alcohol-Based for Non-Porous Ink Jet Systems:

Product	Part Number	Package
Conditioner, TSO-SC	5750-650	2/case
Ink, TSO-3100 Black	5750-651	6/case
Ink, TSO-2 Red	5750-652	6/case
Maintenance Spray, TSO	5750-657	2/case

Assembly Drawings

Appendix B3

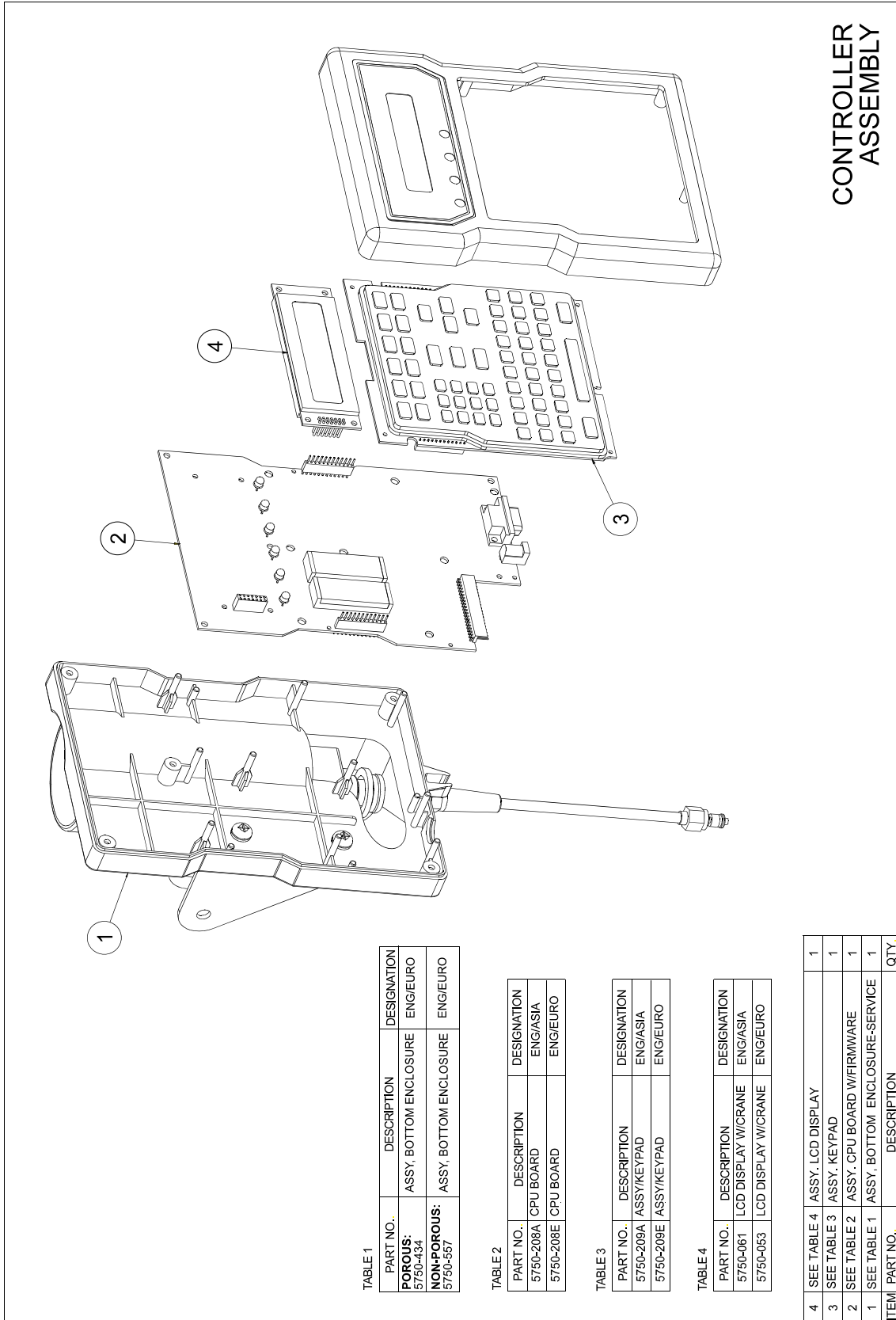

CONTROLLER ASSEMBLY

TABLE 1

PART NO.	DESCRIPTION	DESIGNATION
POROUS: 5750-434	ASSY, BOTTOM ENCLOSURE	ENG/EURO
NON-POROUS: 5750-557	ASSY, BOTTOM ENCLOSURE	ENG/EURO

TABLE 2

PART NO.	DESCRIPTION	DESIGNATION
5750-208A	CPU BOARD	ENG/ASIA
5750-208E	CPU BOARD	ENG/EURO

TABLE 3

PART NO.	DESCRIPTION	DESIGNATION
5750-209A	ASSY/KEYPAD	ENG/ASIA
5750-209E	ASSY/KEYPAD	ENG/EURO

TABLE 4

PART NO.	DESCRIPTION	DESIGNATION
5750-061	LCD DISPLAY W/CRANE	ENG/ASIA
5750-063	LCD DISPLAY W/CRANE	ENG/EURO

ITEM	PART NO.	DESCRIPTION	QTY
4	SEE TABLE 4	ASSY, LCD DISPLAY	1
3	SEE TABLE 3	ASSY, KEYPAD	1
2	SEE TABLE 2	ASSY, CPU BOARD W/FIRMWARE	1
1	SEE TABLE 1	ASSY, BOTTOM ENCLOSURE-SERVICE	1

Assembly Drawings

continued Appendix B3

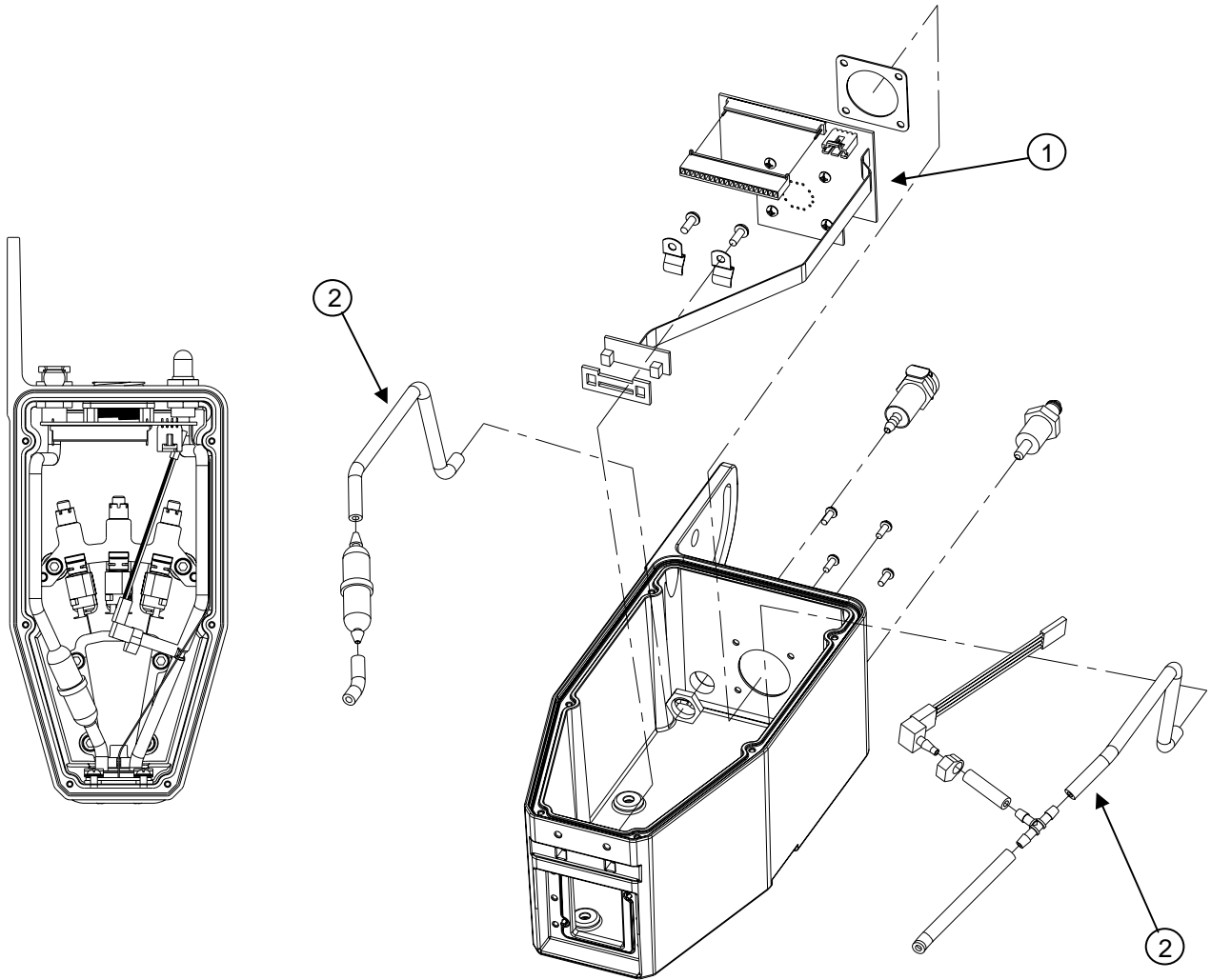

2	5770-205	PRINthead TUBING KIT	1
1	5770-204	PRINthead PCB KIT	1
ITEM	PART NO	DESCRIPTION	QTY

PRINthead ASSEMBLY

Assembly Drawings

continued Appendix B3

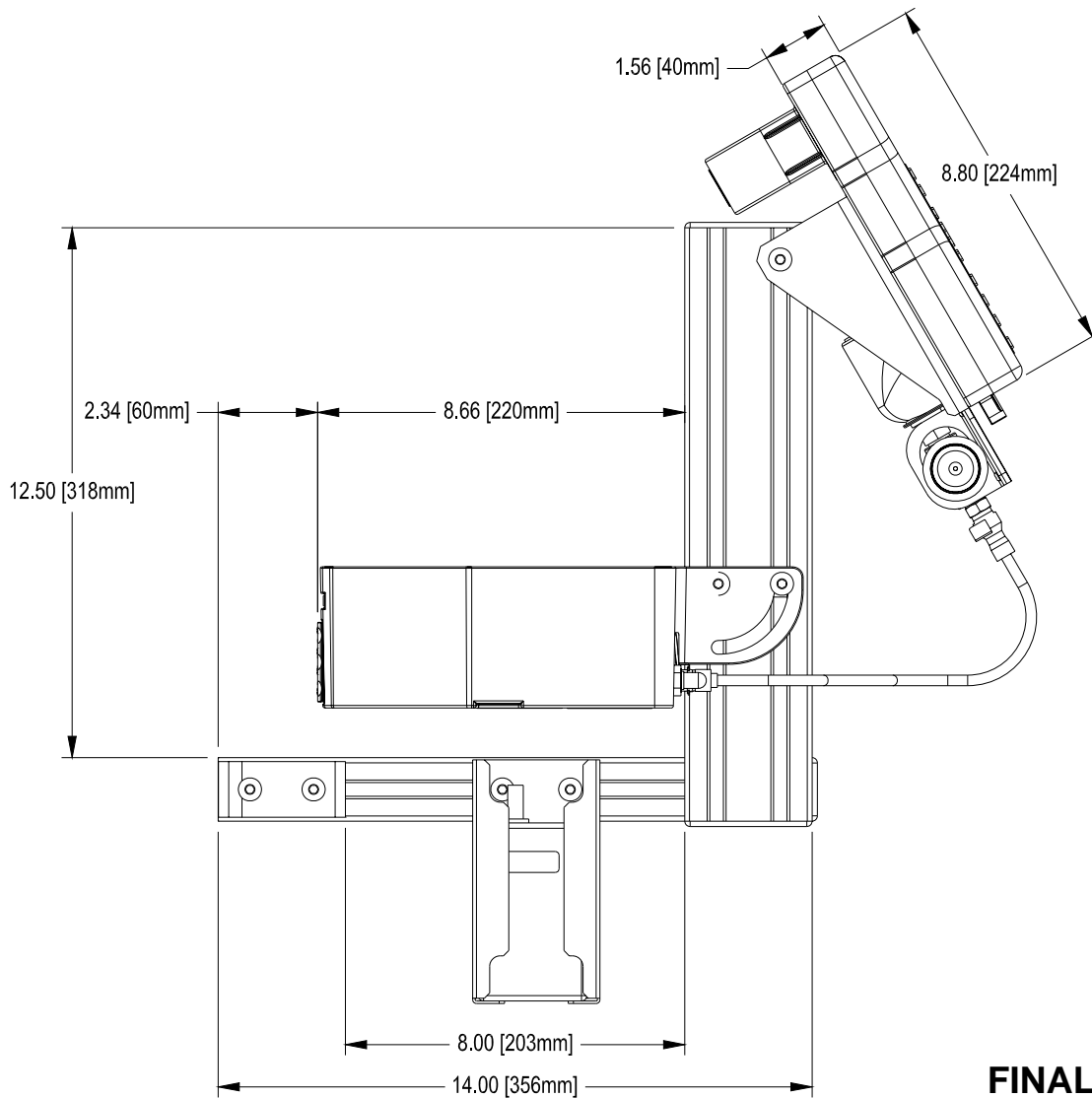
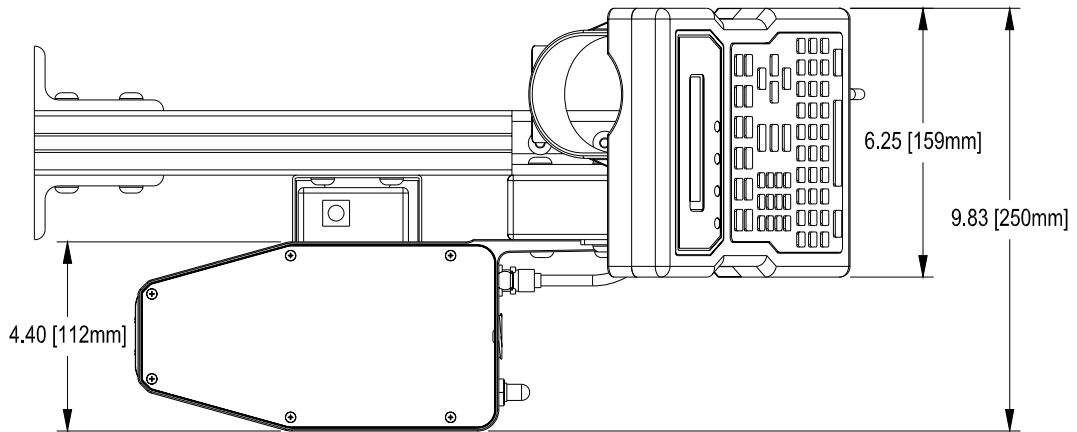

FINAL ASSEMBLY

Theory of Operation

Appendix C

Mechanical

Appendix C1

System Fluidics:

Ink flows into the printhead from a pressurized “ink can” supply [A]. The ink can is filled to 50 psi which allows it to completely discharge its ink and maintain an adequate supply pressure to the printhead. An ink-pressure regulator [E] reduces the ink pressure to 7-psi for system operation. Regulator settings must be 7-psi output to maintain consistent dot-diameter and printhead operation. A pressure transducer [F] inside the printhead monitors operating pressure. When ink pressure falls below 5 psi, the transducer sends a signal to the controller [B] to indicate that the can is empty. The controller lights an “ink low” LED as an operator warning of low ink supply . As the ink can empties, the ink pressure quickly drops until it is insufficient to completely eject ink from the printhead. Very low ink pressure pushes a small amount of ink onto the surface of the orifice plate. As a result, the orifice plate should be cleaned each time the ink can is replaced.

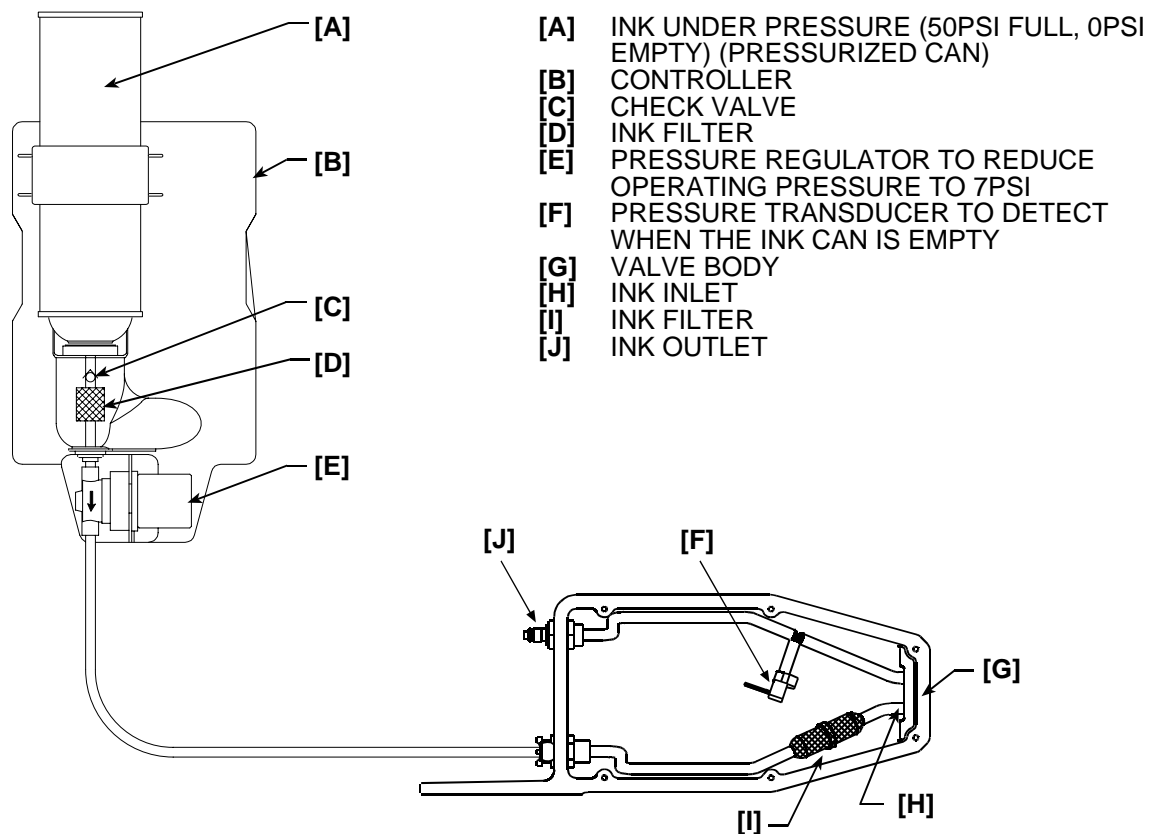

Mechanical

continued Appendix C1

Printhead Operation

Ink flows into the printhead through an inlet filter [E], and into the valve body. The valve body consists of a back plate [F], membrane [N], chamber plate [G], front seal [H] and orifice plate [L]. Ink flows into the chamber plate and is sealed by the piston applying a force, to push the membrane against the chamber plate post [I]. The membrane sealing force (pre-load) is initially adjusted to seal against ink pressure at 9 psi to prevent static leakage at the normal operating pressure of 7 psi. This “pre-load” adjustment controls the amount of force the piston [D] applies to the membrane. Rotating the red adjustment nut [O] sets the pre-load pressure by moving the entire solenoid assembly in a linear movement, to increase or decrease piston loading on the membrane (clockwise to decrease pre-load, counter clockwise to increase pre-load).

Valve Body Closed

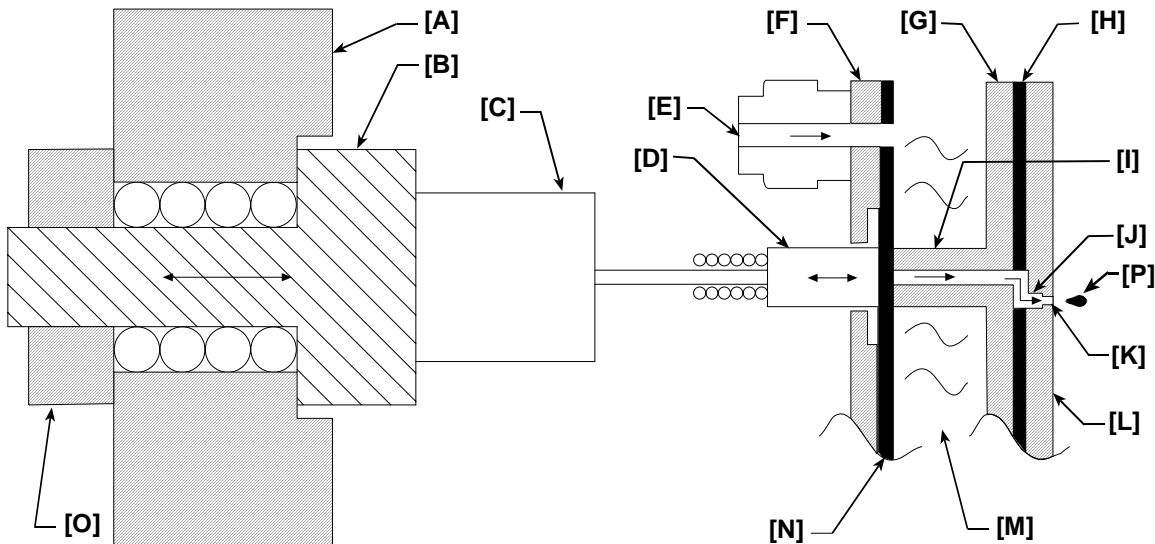

[A] Mounting Strip
 [B] Bushing
 [C] Solenoid
 [D] Piston
 [E] Ink Inlet Filter
 [F] Backplate
 [G] Chamber Plate
 [H] Seal

[I] Chamber Plate Post
 [J] Slotted Channel for Single Column Orifice Array
 [K] Orifice
 [L] Orifice Plate
 [M] Ink at 7PSI
 [N] Membrane (Acts as Valve Seal)
 [O] Adjustment Nut
 [P] Ink Droplet

Mechanical**continued Appendix C1**

Each printhead has seven solenoids to control piston movement. When a piston [D] pulls back, it allows ink [M] to flow between the membrane [N] and through the center of the chamber plate post [I]. Ink flows into the orifice plate and ejects as droplets [P] each time the solenoid [C] is electrically energized. A controlled voltage applied to the solenoid coil causes linear movement of the piston. Increasing or decreasing individual solenoid drive voltages—“pulse width” settings—increases or decreases droplet volume and dot diameters. Operating pressure must be maintained at 7 psi to achieve consistent droplet volume and dot diameter.

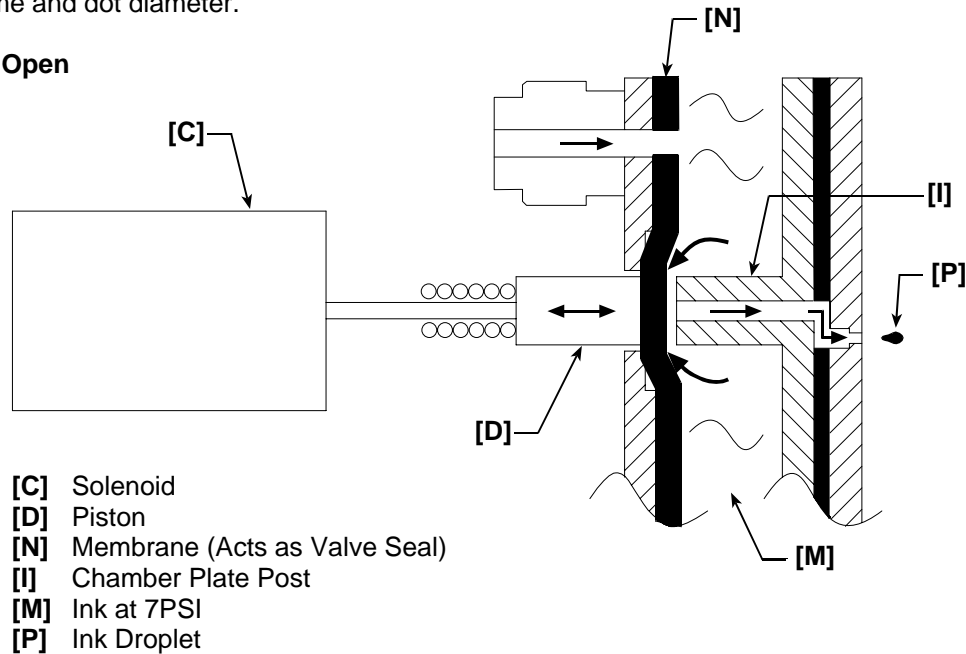
Valve Body Open**Electrical****Appendix C2**

The system consists of three assemblies: the controller, which contains the Motorola 68332 microprocessor-based CPU board; the printhead/driver board assembly; and the 15VDC-power supply.

The external 15VDC-power supply supplies the system voltage. The 15VDC supplies power for the printhead solenoid drive, the ink pressure sensor circuitry, and the optional external photosensor. A switching regulator on the CPU board supplies the 5VDC logic voltage. A battery monitor circuit supplies battery voltage to memory when the 5VDC supply falls below the battery voltage level.

Printhead solenoids are energized by FETs (field-effect transistors) located on the driver board. The FETs are driven by processor TPU (time processing unit) lines, which allow independent pulse-width settings through firmware control. Product detection is achieved by either external or printhead photosensors through firmware selection. The printhead photosensors or a preset by firmware control determines product speed and direction. Phase-lock loop circuits at 10kHz and 12kHz operate the printhead photosensors and prevent false triggering.

The CPU board has 256k of battery backed up RAM for message and configuration data. EPROMS located in the U3 and U4 positions contain the firmware.

A differential pressure sensor located in the printhead housing reads the printhead pressure and triggers the low ink alarm when the ink pressure falls below the usable level. Printhead pressure can be read at the driver board TP3 at 1V/PSI.

The controller LCD display defaults to one line all black characters, and is configured for two-line mode and cleared during the system boot-up process.

Electrical Block Diagram

