



4100.1e

Operator's Manual

**4100-010
Revision B**

FoxJet, an ITW company, continually improves its products, and reserves the right to change or discontinue specifications and designs shown in this manual without notice and without incurring obligation. FoxJet has made every effort to verify the information contained in this manual, but reserves the right to correct any error at the time of the manual's next revision.

**© 2010 Illinois Tool Works Inc. All rights reserved.
Printed in the United States of America**

1.0 Introduction



1.1 The 4100.le Label Applicator

The 4100.le is capable of dispensing labels at speeds up to 41 cm/s (80 FPM). This system uses a Patent-Pending rewind drive system that eliminates a drive and nip roller assembly. This design allows the system to perform operation from a single Brushless-DC Servo Motor.

1.2 Product Safety

Safety awareness is critical when working with equipment that contains moving parts and extending electric actuators. Please read all warnings and cautions thoroughly before operating this device.

This product meets the requirements of CAN/CSA-22.2 NO.60950-00 * UL 60950 using FoxJet an ITW Company approved items. Units are only tested and qualified with FoxJet an ITW Company approved parts and accessories. Use of other parts or accessories may introduce potential risks that FoxJet an ITW Company can assume no liability for.

WARNINGS

- **WARNING - Moving parts of this machine can present hazards. Components that cannot be guarded because of loss of functionality are marked with a warning symbol.**
- **Be aware of the actuator extension distance, and avoid accidental triggering of the photosensor.**
- **When servicing the unit's electronic assemblies, always remove the power cord from the unit to prevent accidental shock.**
- **When running for extended periods of time, use caution when accessing the drive module circuitry. The motor drive power transistors, motor case, and motor heatsink can become hot under constant use.**
- **Wear personal protective equipment, as instructed by your supervisor, when operating or working near this device.**

COMPLIANCE

- **CAUTION: Not for use in a computer room as defined in the Standard for the Protection of Electronic Computer/ Data Processing Equipment, ANSI/NFPA 75.**
- **ATTENTION: Ne peut être utilisé dans une salle d'ordinateurs telle que définie dans la norme. ANSI/NFPA 75 Standard for the Protection of Electronic Computer/ Data Processing Equipment**
- **This unit has been tested and found to comply with the limits for a Class A device, pursuant to part 15 of the FCC Rules.**
- **This unit has been tested to comply with CE Standards.**
- **This unit is equipped with an Emergency Stop switch. Depressing this switch will cause all machine operations to cease.**

- This unit was tested and it was determined that a potential for tipping exists in certain orientations. In compliance with UL safety standards, the stand must be secured to the surface where it is located. Additionally, this type of securing will result in greater product application accuracy.

1.3 Warranty Information

The 4100.le labeler, including all components unless otherwise specified, carry a limited warranty. For all warranty terms and conditions, contact FoxJet, an ITW Company, for a complete copy of the Limited Warranty Statement. Also available on the FoxJet web at www.foxjet.com.

1.4 Specifications

General Specifications

Category	Parameter
Dimensions (with Yoke)	32 in. (813 mm) L x 19 in. (483 mm) H x 23 in. (584 mm) D
Weight	38 lbs (17.3 kg) (includes yoke, no stand)
Accuracy	±0.0625 in. (±1.58 mm)
Certifications	CE, CSA, FCC approved, Listed (UL 60950)
Supply Roll Capacity	4100.le 14 in. (355.6 mm)
Label Length	1 in. (25.4 mm) Min. to 14.0 in. (355.6 mm) Max.
Label Width	1 in. (25.4 mm) Min. to 5 in. (127 mm) Max.
Dispense Speed	10 FPM (5 cm/s) Min. to 80 FPM (41 cm/s) Max.
Product Rate	1 in. Label 380 PPM Max. 2 in. Label 280 PPM Max. 6 in. Label 120 PPM Max. 12 in. Label 60 PPM Max.
Temperature	41°F - 104°F (5°C - 40°C)
Humidity	10 to 85% RH, Non-Condensing

Electrical Specifications

Category	Nominal	Minimum	Maximum
AC Voltage Supply	100 - 240 VAC, 1.6A 50/ 60 Hz	90 VAC 47 Hz	264 VAC 63 Hz
Product Detector	Low: 0 to 3 VDC High: 3 to 5 VDC Supplies 24VDC	0 VDC	24 VDC
Product Detector Pulse Width	10 mS	1 mS	Infinite
Warning Tower	0 and 24 VDC 1 Amp sinking	0 VDC 0 mA	24 VDC 1.5 Amps sinking

System Dimensions

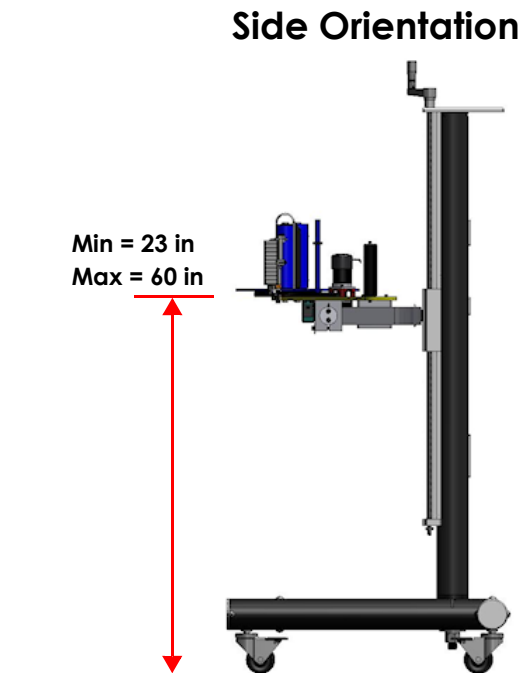
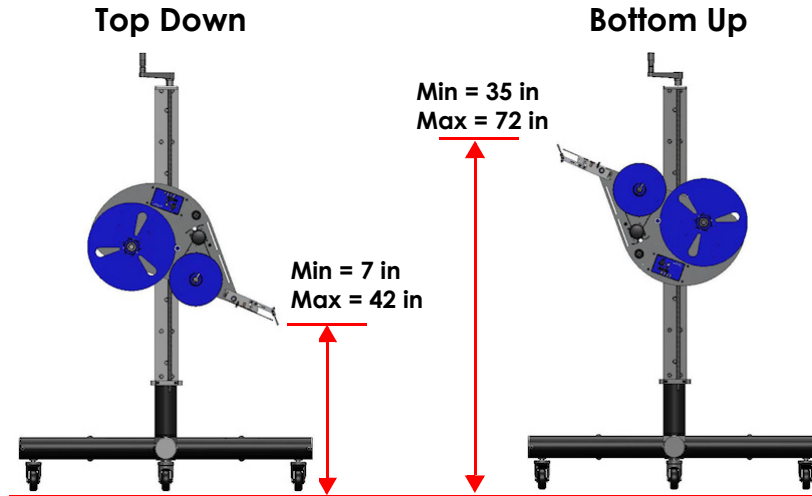
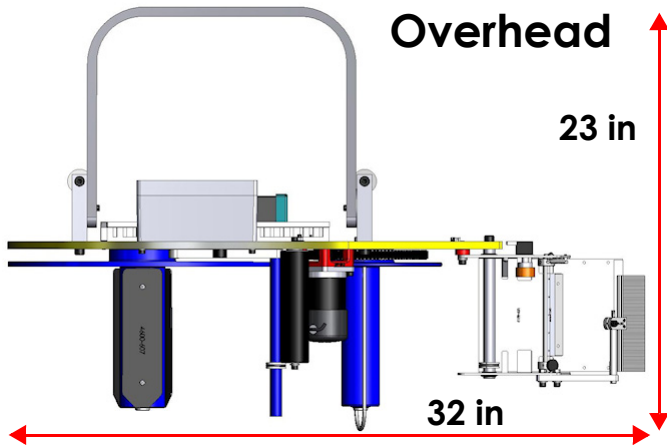
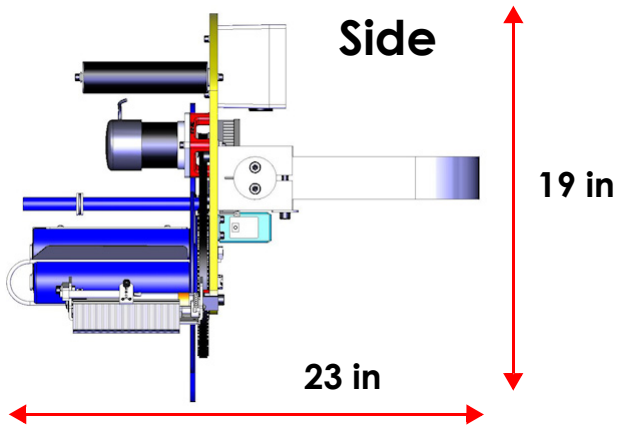
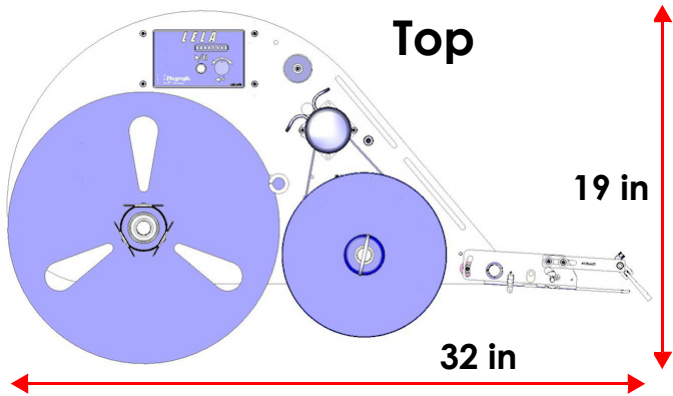

2.0 System Modules



Electric Control Module

- Contains LED Alpha-Numeric Display
- Controls all operation
- Drives Servo motor

4100-500

Dancer Arm

- Non-rotating spindle 4600-643
- Performs label/liner braking

4600-617

BLDC Motor Drive

- Long-life, Brushless DC Motor
- Hall-Effect Sensors for speed feedback

4600-503

Product Detector

- Diffused light sensor
- 900 mm range
- Light or Dark Operate
- NPN Signal

4600-900

* Warning Tower



- Red, Yellow, and Green LED bulbs
- 24 VDC 5W

6000-828

Unwind Supply Roll

- Indestructible ABS Material
- 14 in. (355 mm) Disk
- 3 in. (76 mm) ID Core

4600-605

Rewind Liner Take-Up

- Indestructible ABS 1-pc Material
- Simple clasp liner keep

4600-606

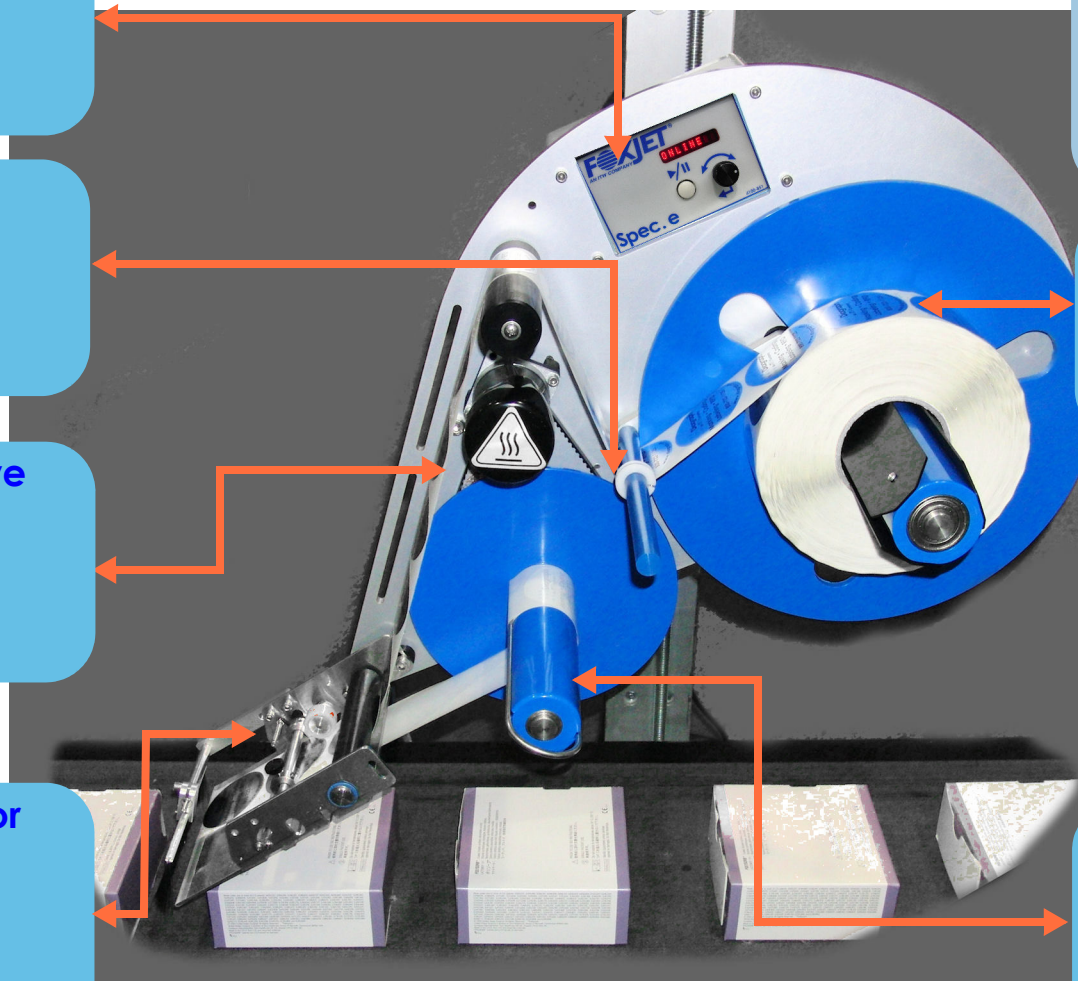

System Modules

* = Denotes Optional Equipment

3.0 Theory of Operation



The operation of the label dispensing is quite simple. The Product Detector supplies a signal that starts the application sequence. The sequence begins with the countdown of the Delay timer. This value is determined by the user, and it is used to set the position of the label on the product. This is dependent on the speed of the product and the desired location on the product. Once the Delay timer expires, the label feed begins. The label is ramped up to the desired Speed almost instantaneously. This speed is set by the user to match the product's speed on the conveyor. Once the label gap is detected by the labeler's gap sensor, the label is dispensed as far as the Position value dictates. This allows for handling labels of various lengths and shapes, without having to make any mechanical adjustment to the sensor itself. Once the Position is reached, the label liner advancement is halted and the application cycle is considered complete.

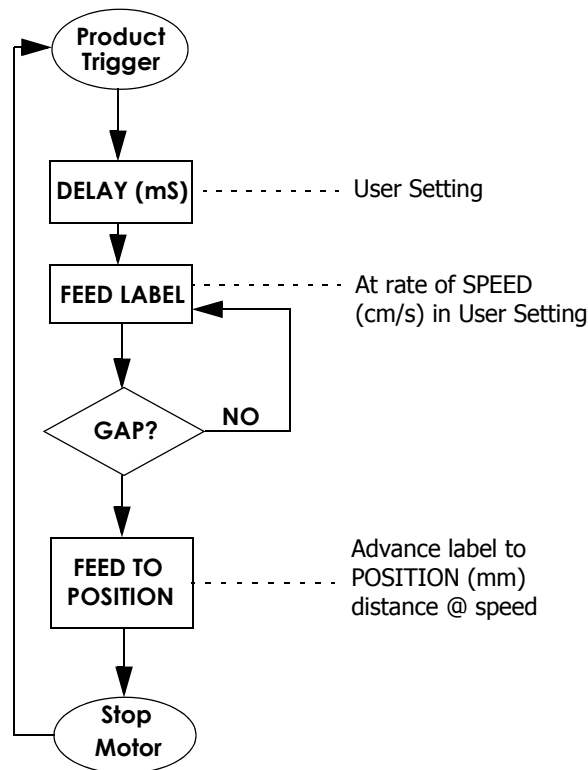

4.0 Setup



STEP 1

Connections

Setup

Most of the system cable connections are located inside the Electronic Control Module (ECM). This includes the jumper location for selecting Left-Hand system operation (default is Right). The ECM is located on the rear of the system baseplate. Remove the four (4) Phillips-head screws for attaching the:

- Product Detector
- Optional Warning Tower
- Optional Serial Port Connection



ECM location on rear of the baseplate (shown covered)

ECM with rear panel opened

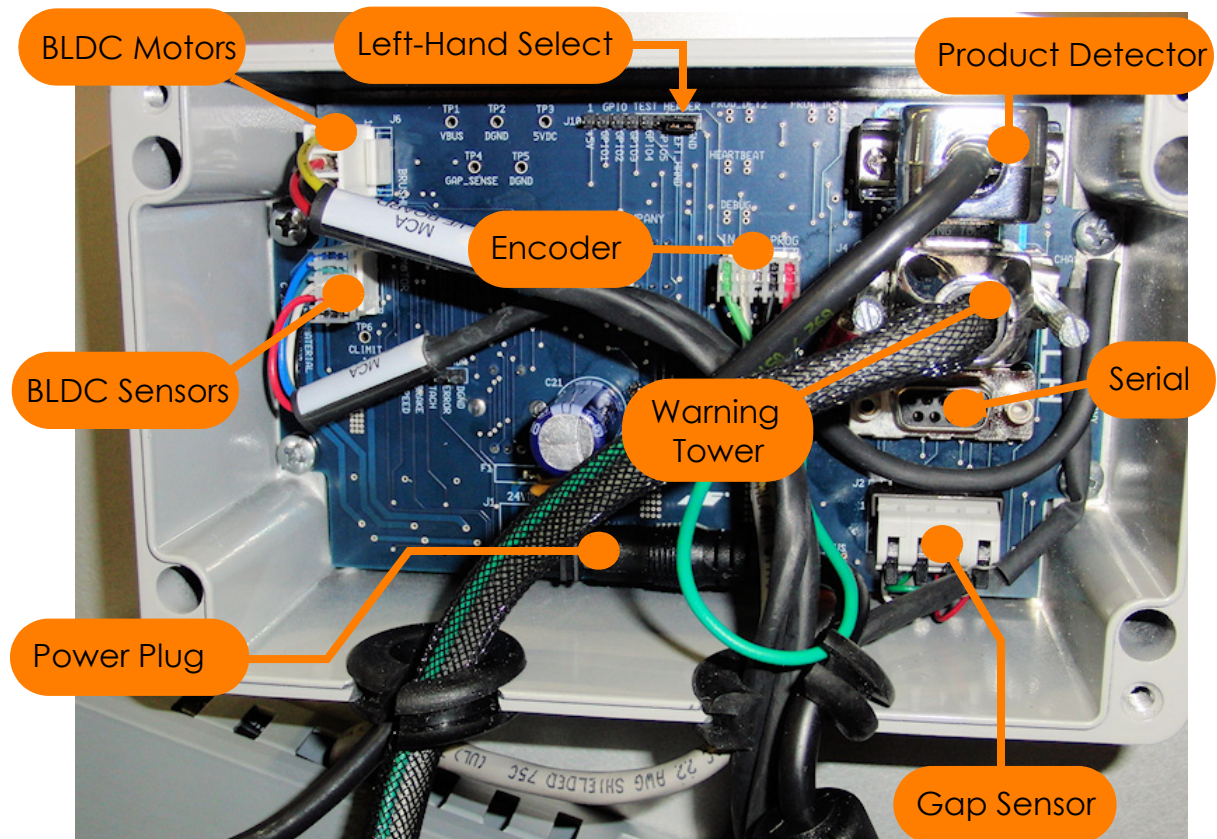

STEP 2

Determine Labeler Orientation

Orientation



Side Orientation

- Side panel of product is to be labeled
- Corner wrapped panels
- Label is to be applied in landscape orientation
- **Not** for tall conveyors where roll change out would be difficult

View

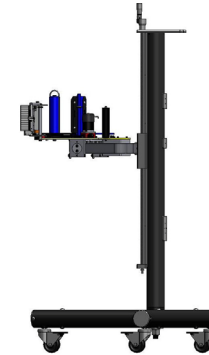

Top-Down / Bottom-Up Apply

- Top or Bottom panel of product is to be labeled
- More material handling is required for Bottom-Up applications

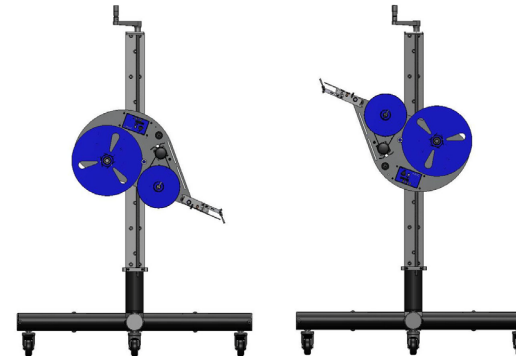

STEP 3**Labeler Alignment with Product****Optimum Labeling Head Positioning**

The labeler should be adjusted for position to the product through the yoke, which rotates about two axes. The labeler must be rotated on these axes to obtain a parallel surface when the peel edge meets the product's surface.

Label Supply Roll Positioning

The labeler will not work properly if the label supply angle is beyond 90 degrees, with respect to the ground. This will allow the label roll to slip off of the labeler and can cause liner tracking problems within the labeler.

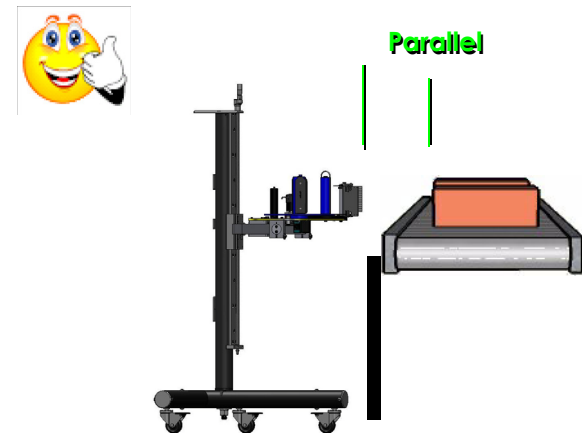
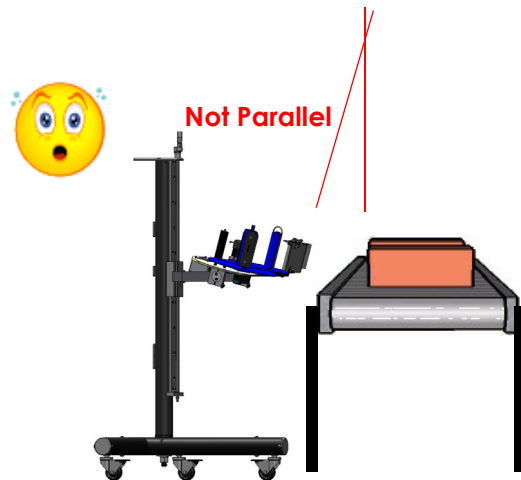
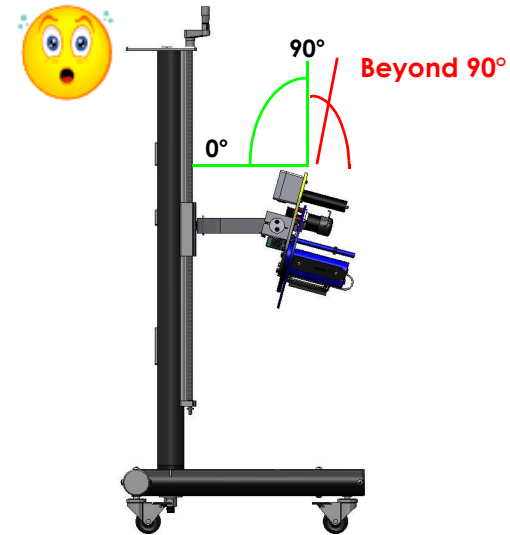

STEP 4 Adjust Settings

Controls

The 4100.le uses two controls for all of its operational control and value adjustments. The white pushbutton provides three functions:

- When offline, a press of the button transitions the system to online
- When online, a press of the button transitions the system to offline
- When offline, a press and hold of the button feeds one label for test purposes

The black rotary knob allows for menu and value changes. It incorporates a pushbutton for selection. Use the rotary knob to slowly make incremental value changes or rapidly turn to advance the amount by greater values.



Pushbutton control
Press once to run or pause the system. Press and hold to feed a label

Shuttle control
Adjusts values up and down. Press to set.

Navigation

The 4100.le minimizes control complexity by using a minimum set of parameters to adjust the system operation. There are three basic application adjustments:

- Delay - This is the time to wait in between the product trigger and the start of label application
- Position - This is the distance the label is dispensed beyond the detection of the label's gap. When a label is being dispensed, it is fed forward until the gap is detected. Once the gap is detected, the label will normally need to be fed further to line up the next label on the peel blade edge. This value adjusts this distance.
- Speed - The speed should closely match the speed of the product

There is a built-in label counter that can be viewed while online or in the Information Menu (INFO). This value is reset to zero at power-up and can be reset by pressing the black knob while viewing the count.

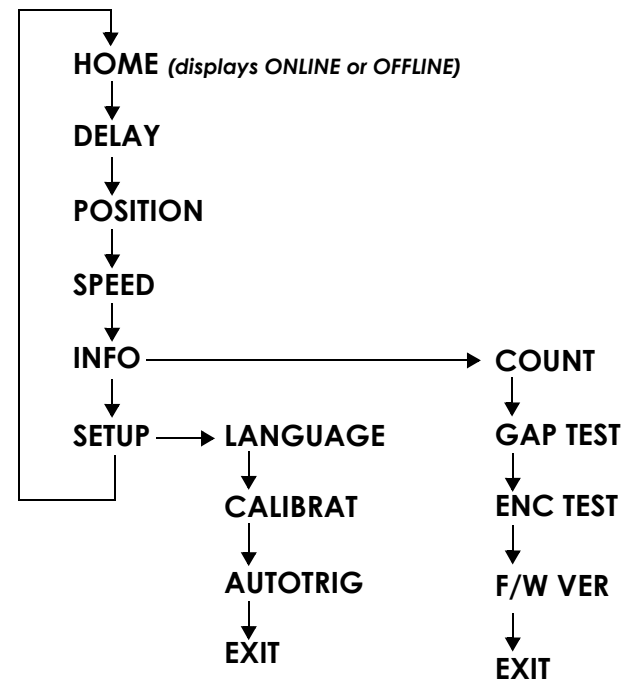

STEP 5**Load the Media****LABEL SUPPLY CHANGEOUT**

Begin by removing the last supply roll core and remaining label liner from the labeler. Insert the new roll over the unwind fins and press roll firmly against the unwind disk [A]. Optionally remove several labels from the liner to create a leader. Route the liner under the dancer arm [B] and over the idler roller [C]. Pass the liner under the peel blade shaft [D], through the label gap sensor [E], under the liner speed encoder [F], and hold down plate [G]. Curve liner around peel blade edge and attach to rewind hub [H], using rewind clasp [I] to hold the liner in place. Using the rewind clasp makes removal of the label liner much easier, as it releases the tension on the take-up roll.

With the labeler offline, press and hold the feed button (white user interface button) to register the first label; before the labeler is returned online and the labeler begins running. The label change out can be accomplished in less than 30 seconds by an experienced user.

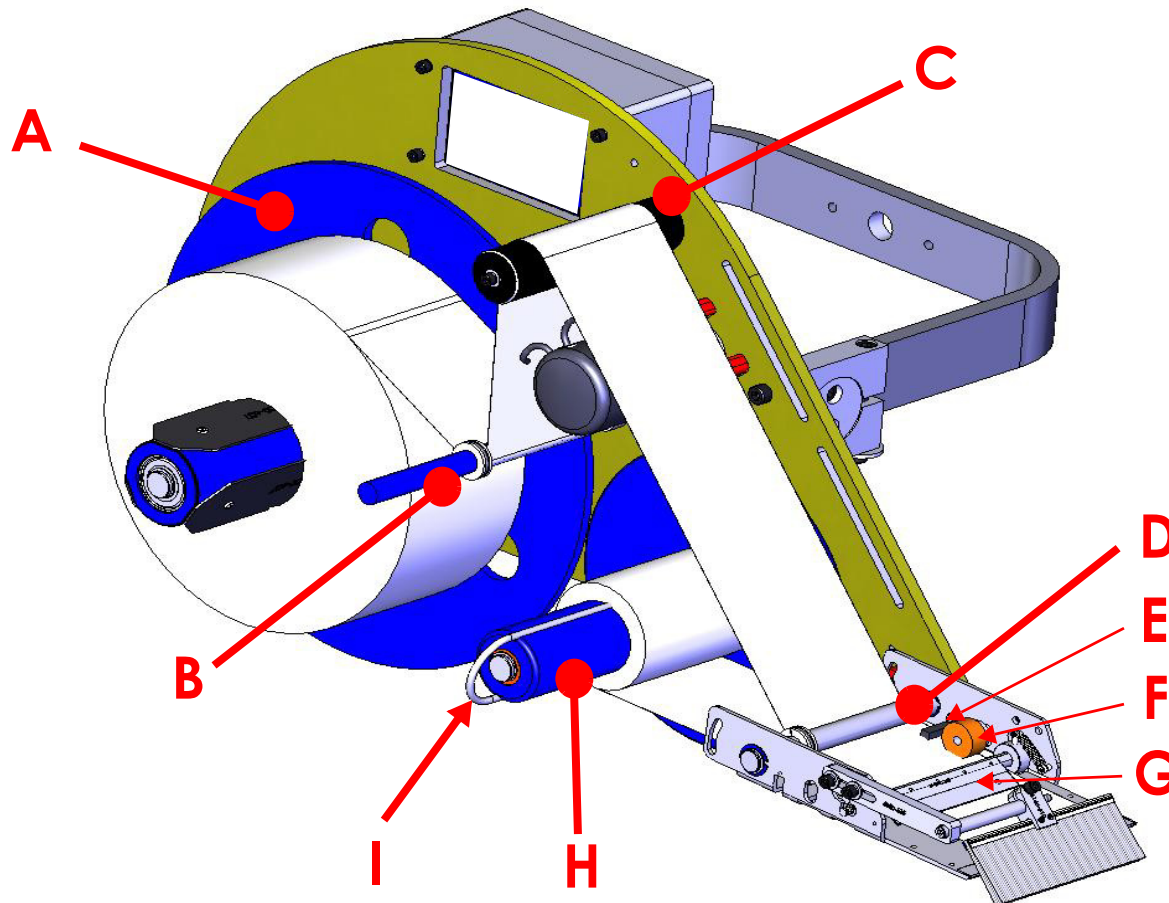

STEP 6**Product Detector****Product Detector for the Application**

The standard product detector offered is the Diffuse Light 4600-900 sensor. There are two optional sensor types, one is a break-beam sensor, and the other is a laser with background suppression. The proper product detector can make the difference in label placement and operation.

Product Detector Selector			
Application Detail	Diffuse Light (4600-900)	Break-Beam (4600-901)	Laser (4600-902)
Corrugated brown case, no pre-print	✓	✓	✓
Corrugated brown case, pre-print	x	✓	✓
Tray packs with product gaps in pack	x	✓	✓
Pallets	✓	✓	x
Shrink wrapped products	x	✓	✓
Primary product	✓	✓	✓
Primary product, high speed, high accuracy	x	x	✓

Product Detector Mounting Location

The product detector can be mounted off of the peel blade for applications. This location ensures that any movement of the equipment will not effect the Product Delay. There are application set ups where this location will not work, and there are brackets included for remotely mounting the product detector elsewhere. Listed below are the applications that will require the detector to be relocated:

- Side apply configuration, where the clearance is too close for the product sensor to be mounted in between the system and the conveyor
- High line speeds (greater than 60 FPM) and desired label placement close to the front edge of the product
- The product type requires a break beam sensor, requiring a direct line of sight to a polarized reflector

Product Detector Adjustments

All three of the sensors have the same controls for adjustment. Setting S2 (as shown to the right) controls the sensitivity of the detector. With a sample target product in front of the sensor, adjust this setting. The output LED, L2 in the image, will illuminate with the sensitivity adjustment is correct. The power LED, L1 in the image, will show the signal return strength when the output LED is on. Make sure the sensitivity is set so the green LED is on solid so that slightly less reflective products will still cause a trigger. Once the product is removed from the field of view of the sensor, the green LED will return to indicating power, and will be strongly illuminated.

For break-beam applications using the 4600-902 sensor, the Light/Dark setting S1 should be changed. This inverts the output signal mode to the applicator. Since a break-beam application will normally have an active output for no product detected, the change of S1 will allow the triggering to react to the presence of the product.

Sensor Notes

The break-beam sensor has a polarized retro-reflective lens. This means that it requires a suitable reflector that can provide the correct light phase shift to satisfy the sensor. This prevents reflective products (shrink-wrap, glass, etc.) from falsely triggering the sensor.

The laser sensor incorporates a triangulation method to receive the reflected beam. Using this method, the sensor detects true distance rather than product reflectivity. The setting made on S1 will determine distance to the target product. If products will range in distance, the furthest distance product should be used for adjustment. Ensure that objects beyond the target product range are not detected to avoid false triggers.

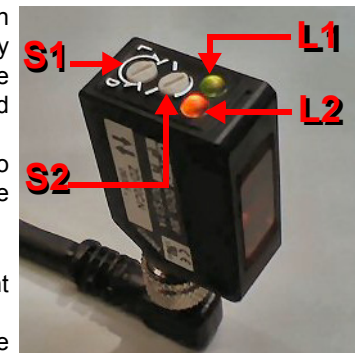

STEP 7

Configure Application Settings

Set the POSITION Value

When the system dispenses a label, it looks for the first label to liner transition (trailing edge of label). Once found, it continues to advance the label for the distance set in the POSITION setting. This arrangement allows for rectangular, circular, and other various label shapes to be used with this sensor. There is one trade-off, however. Since it triggers the gap from the first trailing edge, care should be taken when setting the POSITION value so that the label isn't on the edge of the trailing position. This will cause double feeds or impulse feeds. The following table shows the typical POSITION values, based on the standard gap sensor to peel blade edge position.

Table 1: Label Length Table

Label Length (in)	Label Length (mm)	POSITION Value (mm)
1	25.4	10
2	50.8	2
3	76.2	5
4	101.6	57
5	127	30
6	152.4	5
9	228.6	160

Position Example

Q: Given a round label that measures 2.5 inches wide by 2.5 inches long, what should the Position value initially be set to?

A: Since the label trips the gap sensor off of the trailing edge, there is roughly 1.3 inch of travel required after the gap to advance the next label to the edge of the peel blade. This means that a Position value of **33** (1.3 in. * 25.4mm/in.) is required.

If the label was a rectangle, we would not have to advance such as large gap distance.

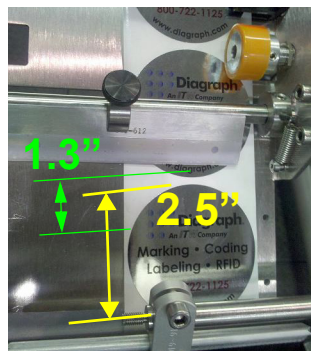

Set the SPEED Value

The speed is set in the metric units of cm/s. The table below shows the close equivalent of $cm/s * 2 = FPM$.

Table 2: Label Speed Table

Speed (cm/s)	Speed (FPM)
5	9.84
10	19.68
15	29.52
20	39.37
25	49.21
30	59.05
35	68.89
40	78.74
45	88.58

Speed Example

Q: What is the Speed setting required for a 75 FPM conveyor?

A: Using the divide by 2 estimation above, a value of 37 cm/s can be tried. The precise value would be 38.1 cm/s, so 37 would be a close estimation.

STEP 8

Configure Application Settings (Cont.)

Set the DELAY Value

This is measured in milliseconds (ms). The system will be the most accurate for label placement with the delay value as small as possible. This means that the product detector should be placed parallel to the desired label location on the product. This is usually not right on the peel blade edge, unless the desired label placement is right on the product's leading edge, but rather a location downstream of the peel blade.

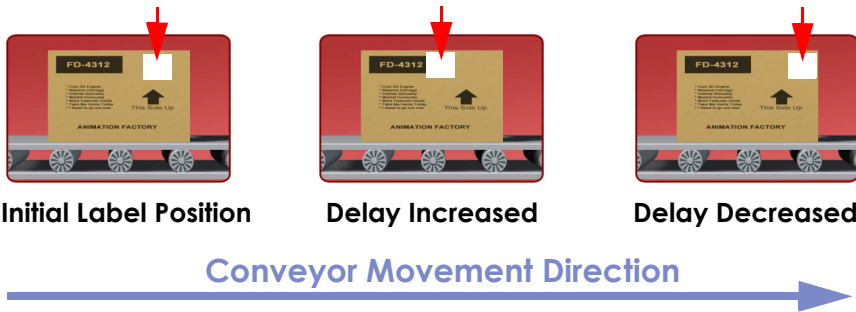

Set the Machine Hand Configuration

This should be set at the time of manufacture. The system can either be a Left or Right hand system. This is determined by the orientation of the label image and the position of the system on the conveyance line. If the jumper is placed across pins 1 and 2, the system will perform as a left handed system. No jumper indicates a right hand system.

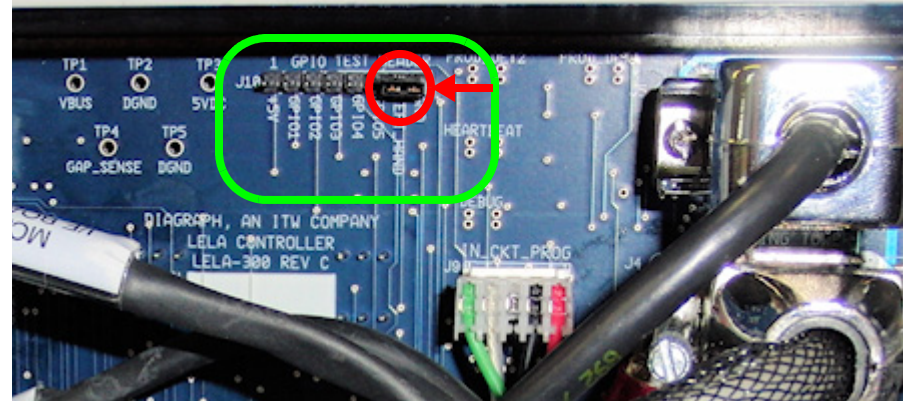

Calibrate the GAP Sensor

Place a clear section of liner in the gap sensor (see picture on right). It is important that the liner is under some tension, to represent the position experienced when running.

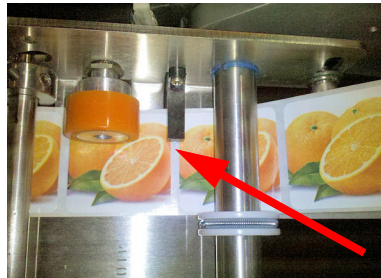

Enter the Setup menu, and select CALIBRAT(E). Follow the instructions on the display, which require the user to press the black knob to set the value. This value will be displayed on the screen. Normal values are between 20 and 40. This represents how much light is getting through the liner.

A value of 60 indicates there is an error, or the liner is too opaque. Recycled paper or kraft paper can be too opaque for the standard sensor, and cannot be used. A value less than 10 indicates either a clear liner (which is okay to use), or a problem if the liner is standard paper.

Label Unwind Direction and Machine Orientation

For reference, the label unwind chart is listed below. Types 3 and 4 must be matched to the hand of the labeling system. Type 3 should be used on a left-handed system, while a Type 4 should be used on a right-hand system.

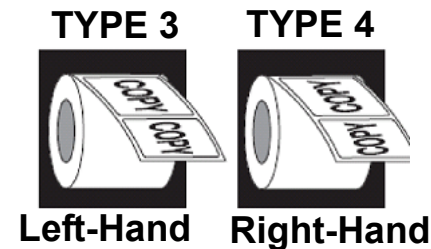

STEP 9**Runtime Adjustments**

Observed	Reason	How to Correct
FEEDING ISSUES		
LABEL FEEDING OUT TOO FAR	<ul style="list-style-type: none"> Position value incorrectly set 	<ul style="list-style-type: none"> Use Label Length Table on page 14
LABEL NOT FEEDING OUT FAR ENOUGH	<ul style="list-style-type: none"> Position value incorrectly set 	<ul style="list-style-type: none"> Use Label Length Table on page 14
LABELS FEED OUT WITHOUT PAUSING AT LABEL GAP CONTINUOUSLY	<ul style="list-style-type: none"> Label Gap Sensor not calibrated Gap Sensor not connected, dirty, damaged, or faulty 	<ul style="list-style-type: none"> Calibrate Label Gap Sensor according to instructions <u>Calibrate the GAP Sensor on page 15</u> Check connections and verify gap sensor is clear of dust and contamination. Clean with compressed air or optical cleaning solution. Test sensor readings in Diagnostics as described in <u>Diagnostics on page 17</u>
LABEL DOUBLE FEEDS ONCE IN A WHILE	<ul style="list-style-type: none"> Label Gap Sensor needs re-calibration Gap Sensor dirty, damaged, or faulty Label stop position on edge of label gap 	<ul style="list-style-type: none"> Calibrate Label Gap Sensor according to instructions <u>Calibrate the GAP Sensor on page 15</u> Clean with compressed air or optical cleaning solution. Test sensor readings in Diagnostics as described in <u>Diagnostics on page 17</u> Increase (or decrease) Position value to avoid label stop on edge of next label.

5.0 Troubleshooting



Error Messages

These messages are displayed in a scrolling manner across the red LED screen.

“ERROR...LABELS OUT”

Meaning	Label supply is empty
Detected	The web encoder does not detect movement of the liner when the motor is commanded to move
Solution	Replace label roll

“ERROR...MOTOR CIRCUIT OR MOTOR SENSOR”

Meaning	BLDC Motor Driver Reports an Error
Detected	<ul style="list-style-type: none"> • Motor stalled • Hall Effect sensor cable not connected or damaged • Undervoltage lockout • Invalid commutation sensor code • Shutdown, or overcurrent shutdown
Solution	<ul style="list-style-type: none"> • Liner didn't separate from empty roll core, causing a stall • Check Hall Effect sensor cable (Connecting to J2 on the ECM) • Power supply failure • Incorrect cabling • Stall condition. Cycle power to clear

Diagnostics

These are built-in tests to troubleshoot the sensors

Liner Speed Encoder Test

Test Purpose	Ensures that liner encoder is accurately reading both channels of the sensor, and the proper number of pulses are sensed for a full rotation
Test Step 1	A. Start with the power removed from the system B. Mark a small line on the liner encoder wheel to denote top position
Test Step 2	A. Power on the system B. Enter the INFO menu C. Select ENC TEST
Test Step 3	A. Carefully rotate the liner wheel one rotation B. Do not allow the wheel to jiggle backwards during the rotation C. Observe the count on the display
Results	<ol style="list-style-type: none"> 1. If the count reads around 400, the encoder is working correctly 2. If the count reads around 200, the encoder is missing counts from one channel. Check cabling and encoder. 3. If there is no count, or very few counts, check the cable and/or replace the cable and encoder 4. Make sure encoder wheel setscrew is firmly holding to encoder shaft

Gap Sensor Test

Test Purpose	Verify the gap sensor is seeing the difference between liner and label+liner
Test Step 1	A. Enter the INFO menu B. Select GAP TEST
Test Step 2	With no material in the sensor, the value displayed should be less than 10. If the value is 60, cable the cabling and/or replace the sensor
Test Step 3	With just liner in the sensor, the value should be around 20 ~ 40 for white liner. Recalibrate sensor if otherwise

6.0 Electrical Interfacing



J5 - Product Detector(s)	
PIN	Pin Description
Pin 3	Ground
Pin 4	Product Detector Input 2 (NPN)
Pin 6	+ 24 VDC Supply
Pin 8	Product Detect Input 1 (NPN)
Pins 1,2,5,7,9	N/C

J4 - Warning Tower	
PIN	Pin Description
Pin 1	Ground
Pin 4	Red (Ground Switched)
Pin 5	Yellow (Ground Switched)
Pin 6	+ 24 VDC Supply
Pin 7	Green (Ground Switched)
Pin 8	Auxiliary Output
Pin 2,3,9	N/C

J3 - Serial Communications	
PIN	Pin Description
Pin 2	Transmit RS232
Pin 3	Receive RS232
Pin 5	Ground
Pin 9	+ 5VDC
Pins 1,4,6,7,8	N/C

LELA ECM Board (Cover Removed)

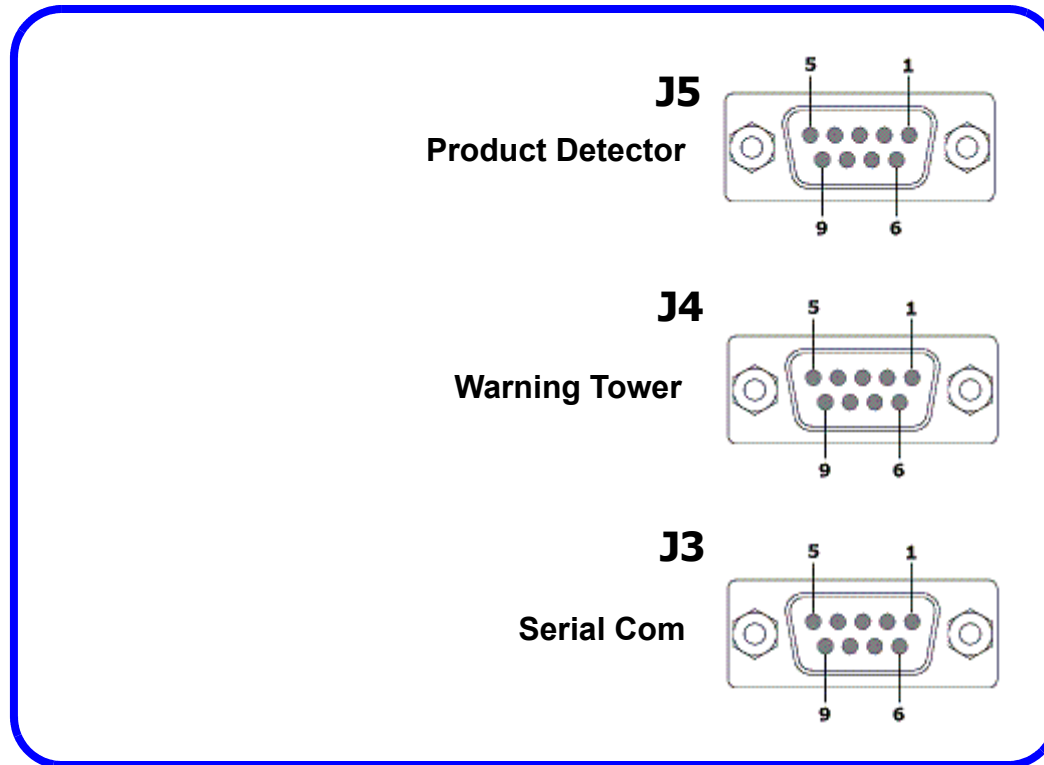

7.0 Maintenance Schedule



Area	Daily	Monthly	Two Years	Description
Clean Label Gap Sensor		√		Use a soft lint-free cloth to wipe all dust and contaminants free. Be careful not to damage the plastic lens with alcohol-based solvents.
Clean Peel Blade /Hold-Down Plate		√		Use isopropyl alcohol and soft lint-free cloth to wipe all dust and contaminants free.
Clean Product Detector Sensor(s)		√		Use a soft lint-free cloth to wipe all dust and contaminants free. Be careful not to damage the plastic lens with alcohol-based solvents.
Clean Baseplate Spindle and Roller		√		Use isopropyl alcohol and soft lint-free cloth to wipe all dust and contaminants free.
Inspect Rewind Belt		√		Check for frayed edges and exposed reinforcement fibers.
Replace Rewind Belt			√	Remove Rewind disk by taking off E-clip. Keep belt loose by loosening the motor mount screws. Replace belt and reinstall the Rewind disk.
Replace Unwind Dancer Spring			√	Unwind spring can be accessed through the slots of the Unwind disk.

8.0 Interconnection Diagram

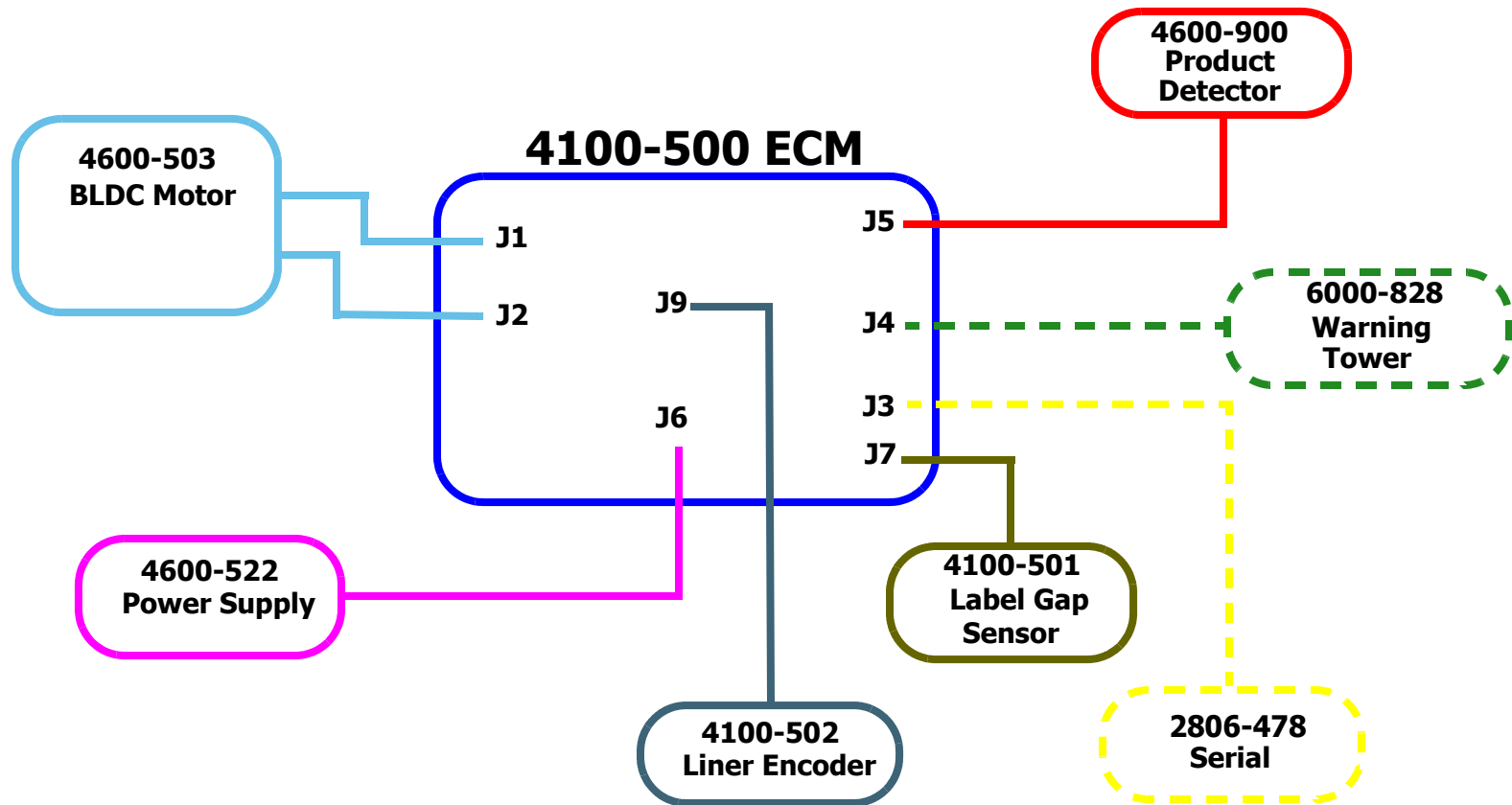

Interconnection Diagram

9.0 Spare Parts List - System



Spare Parts List

Part Number	Recm'd. Spare Part	Description
DOCUMENTATION		
4100-010		4100.le User Manual
4100.le		
4600-522		MCA Power Supply (Auto-Ranging, 24 VDC Output)
4600-511		AC Power Cord
4600-643		Unwind Dancer Arm Spindle
4100-500		ECM Circuit Board Assembly
LELA-300	√	Main MCU PCB Assembly
4600-503		Rewind BLDC Motor
4100-501	√	Label Gap Sensor
4100-502		Liner Speed Encoder
4100-634	√	Liner Speed Encoder Wheel
4600-647		Rewind Clasp
4100-950	√	MAINTENANCE KIT: Wear Items Set Includes: (2) Timing Belts, (2) Spindles, (2/ea.) Springs, (3) Unwind Fins, (4) Web guides, (1) Nylon Brush Replacement
4600-900		Product Detector - Diffused Light
OPTIONS		
6000-828		LED Warning Tower Assembly
4600-622		Stand Cleats (to secure stand to floor, yet allow removal access) Three required per stand

10.0 System Drawings - Top Level



ITEM	PART NO.	DESCRIPTION	MFR. / VENDOR	4100-100R/QTY.	4100-100L/QTY.
44	4600-648	TIMING PULLEY, 15 TEETH		1	1
43	4100-604	TIMING BELT, XL, 135 GRVS X .375" W		1	1
42	6105-423	TIE MOUNT, #4 SCREW		1	1
41	6105-066	SPRING COLLAR		1	1
40	4600-608	SPINDLE, UNWIND-REWIND	---	2	2
39	4100-602	SPACER, MOTOR		1	1
38	6145-665	SPACER, DLERIN, UNWIND/REWIND	---	1	1
37	5081-735	SCR, M8 X 1.25 X 50, SHCS, SS		2	2
36	5081-730	SCR, M8 X 1.25 X 25, SHCS, SS		8	8
35	5081-731	SCR, M8 X 1.25 X 12, SHCS, SS		2	2
34	5081-728	SCR, M5 X 0.8 X18, SHCS, SS		5	5
33	5081-727	SCR, M5 X 0.8 X12, SHCS, SS		8	8
32	5081-737	SCR, M5 X 0.8 X 50, SHCS, SS		1	1
31	5081-736	SCR, M5 X 0.8 X 40, SHCS, SS		1	1
30	5101-601	SCR, M3 X 0.5 X 8, FL HD PH, SS	BUD INDUSTRIES	1	1
29	5072-503	SCR, 3/8-24 X 1", HEX HD CAP, SS		2	2
28	4100-605	REWIND DRIVE ASSEMBLY		1	1
27	4600-647	REWIND CLASP	---	1	1
26	5321-219	RETAINING RING, C-CLIP, 3/4"		2	2
25	5321-217	RETAINING RING, 3/8, SS		1	1
24	4600-607	RETAINER, LABEL CORE	---	3	3
23	4600-900	PRODUCT DETECTOR		1	1
22	4600-522	POWER SUPPLY, 24V, 3.75A, MEANWELL		1	1
21	4600-618	POWER SUPPLY BRACKET		2	2
20	4100-630R	PEEL BLADE ASSEMBLY, RIGHT HAND		1	-
20	4100-630L	PEEL BLADE ASSEMBLY, LEFT HAND		-	1
19	4100-851	OVERLAY, 4100.le		1	1
18	5309-315	NUT, LOCK, M5 X 0.8, EXT TOOTH, ZN		1	1
17	4600-503	MOTOR KIT, BLDC		1	1
16	5331-220	EXTENSION SPRING		1	1
15	4100-603	IDLER ROLLER		1	1
14	4600-616	HOUSING ASSY, PIVOT		1	1
13	5750-039	FASTENER, #6 X 1/2 HI-LO, PAD HD		6	6
12	4100-500	ELECTRONIC CONTROL MODULE		1	1
11	6145-626	EAR, YOKE ATTACHMENT PUCK		2	2
10	6145-602	EAR, YOKE	---	2	2
9	6000-634	CAP, VINYL, ROUND		1	1
8	4600-511	CABLE, LIGHT-DUTY POWER		1	1
7	4100-503	CABLE, GROUNDING Y		1	-
7	4100-503	CABLE, GROUNDING Y		-	1
6	4600-510	CABLE RACEWAY		1	1
5	4100-600	BASE PLATE		1	1
4	4600-617	ARM ASSY, DANCER		1	1
3	6150-600	ANCHOR, EXTENSION SPRING, 8-32		2	2
2	4700-643	3/8 ROUND FEMALE STANDOFF 6" LONG		1	1
ITEM	PART NO.	DESCRIPTION	MFR. / VENDOR	4100-100R/QTY.	4100-100L/QTY.

REVISIONS				
REV	ECN	DESCRIPTION	DATE	APPROVED
A	LPD00471	RELEASE DRAWING	2/3/10	RB

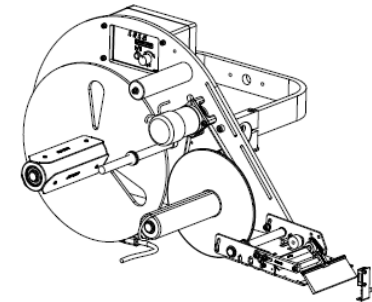

NOTES:

- APPLY LOCTITE 242 TO SCREW PRIOR TO ASSEMBLY.
- 2. TIGHTEN SCREWS TO TORQUE VALUES SPECIFIED ON THE DRAWING.
- COMPONENTS INCLUDED IN THE ELECTRICAL KIT 4100-504.
- CLEAN SURFACE WITH ISOPROPANOL BEFORE APPLYING OVERLAY.
- COMPONENTS INCLUDED IN THE MOTOR KIT, BLDC, 4600-503.
- PLACE TIMING PULLEY FLUSH WITH THE END OF THE MOTOR SHAFT.

53	4100-610	YOKE ARMS		1	1
52	5310-318	WASHER, SPLIT LOCK, #10, SS		2	2
51	5310-801	WASHER, FLT, RD FIBER, 3/4"ID-1"OD		2	2
50	5310-810	WASHER, FLAT, NYLON, 3/8ID-3/4OD		1	1
49	5310-041	WASHER, FLAT, 5/16, SS		1	1
48	5310-030	WASHER, FLAT, #10, SS		4	4
47	5310-049	WASHER, FENDER, 5/16 X 1-1/4 X 1/8		2	2
46	4600-643	URETHANE SPINDLE		1	1
45	4600-605	UNWIND ASSY		1	1
ITEM	PART NO.	DESCRIPTION	MFR. / VENDOR	4100-100R/QTY.	4100-100L/QTY.

CONFIDENTIAL		UNLESS OTHERWISE SPECIFIED:	FILE NAME	4100-000		
THIS DOCUMENT CONTAINS CONFIDENTIAL INFORMATION OF DIAGRAPH - AN ITW COMPANY AND IS NOT TO BE COPIED, USED OR DISCLOSED TO OTHERS WITHOUT THE EXPRESS WRITTEN CONSENT OF DIAGRAPH - AN ITW COMPANY.		ALL DIMENSIONS ARE SHOWN IN INCHES.	OWN	AKNELLER	1/25/10	
		ALL DIMENSIONS APPLY AFTER FINISH.	APP	RBIXEN	2/3/10	
		REMOVE BURRS	APP			
		TOLERANCES:	ASSY PRCD			
	LINEAR: 2 PLACE (XX) ±.015	HOLE DIAMETERS	NET PRCD			
	3 PLACE (XXX) ±.005	ANGULAR				
	MACHINE SURFACE ±.1°					
NEXT ASSEMBLY	MODEL	MATL SPEC	SCALE: 1:8	SHEET 1 OF 7		
			SIZE	DWG NO	REV	
			B	4100-000	A	
			TITLE: LEADING EDGE LABEL APPLICATOR			

10.1 System Drawings - Exploded 1

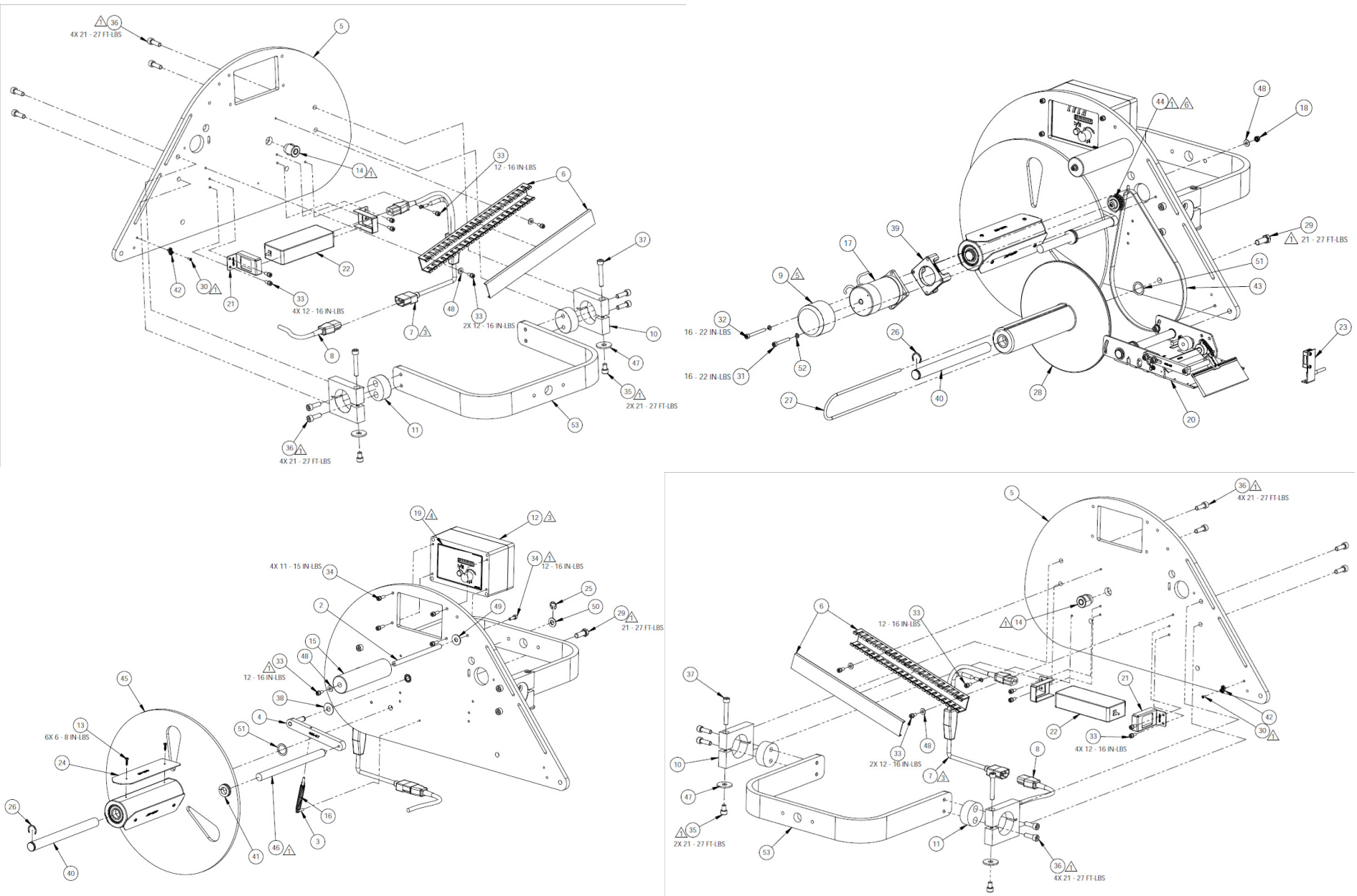

System Drawings

10.2 System Drawings - Exploded 2

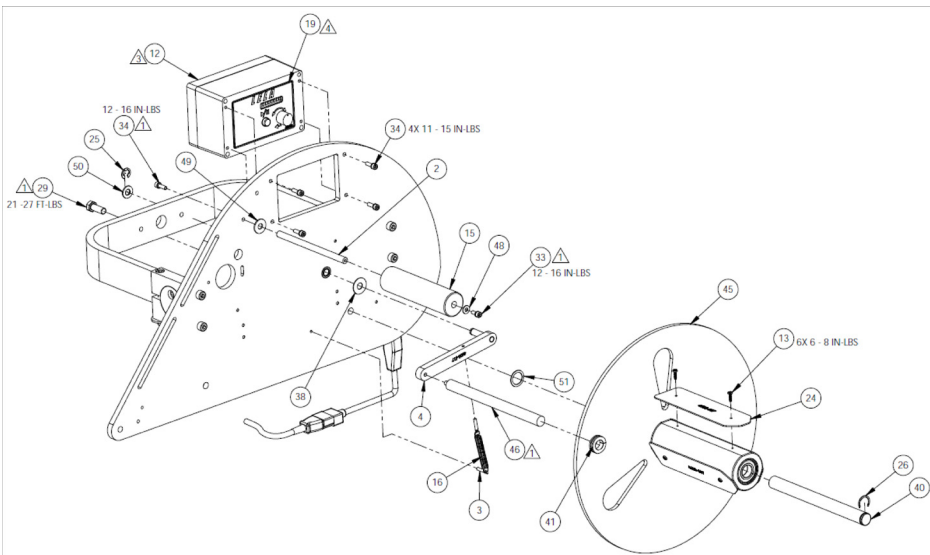

NOTES:
 ⚠ CLEAN THE REWIND ASSY HUB AREA WITH ISOPROPANOL BEFORE ASSEMBLING THE REWIND PULLEY.
 2. TIGHTEN SCREWS TO THE TORQUE VALUES SPECIFIED ON THE DRAWING.

REVISIONS				
REV	ECN	DESCRIPTION	DATE	APPROVED
A	1P000411	CREATED DRAWING	1/25/10	RB

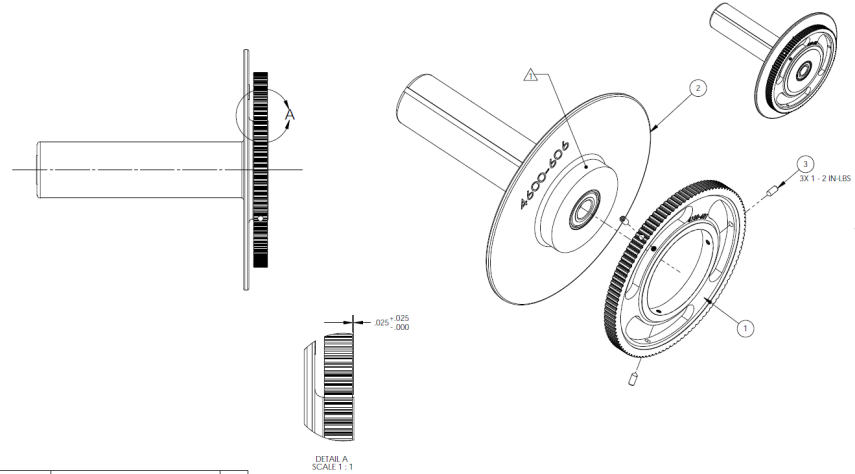

3	500-714	SCR. M5 X 0.8 X 12, SOCKET, CONE PT, SS	3
2	4600-606	REWIND ASSY	1
1	4100-601	PULLEY, REWIND	1
ITEM	PART NO.	DESCRIPTION	QTY

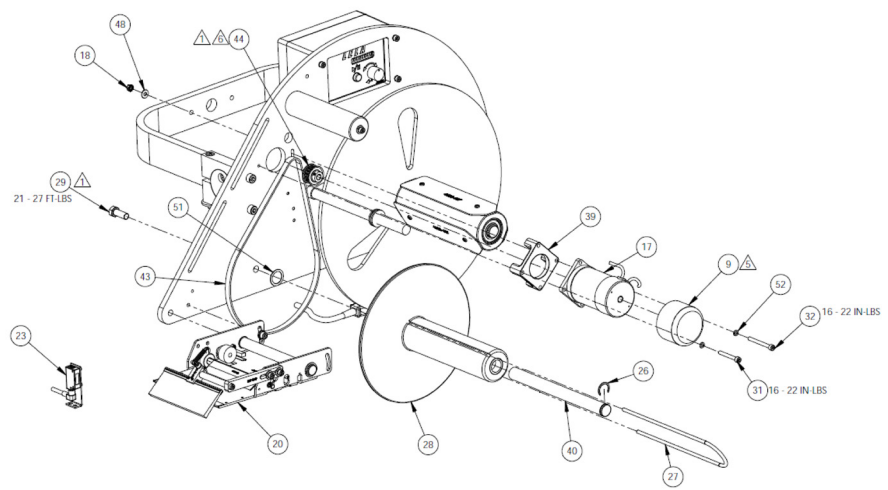

REVISIONS				
REV	ECN	DESCRIPTION	DATE	APPROVED
A	1P000411	RELEASE DRAWING	2/3/10	RB

NOTES:
 ⚠ APPLY LOCTHE 242 TO THREADS PRIOR TO ASSEMBLY.
 ⚠ CLEAN AREA WITH ISOPROPANOL BEFORE APPLYING UHMW TAPE.
 ⚠ PACKAGE MOUNTING HARDWARE, ITEMS 21, 22, 26, 31 & 35, WITH PEEL BLADE ASSEMBLY.
 ⚠ COMPONENTS INCLUDED IN THE ELECTRICAL KIT PART NUMBER 4100-504.

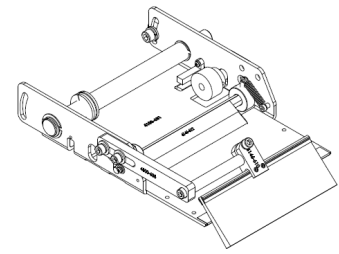

34	5310-313	WASHER, SPRING, 1/4", SS	1	1
33	5310-315	WASHER, SPRING LOCK, #4, SS	2	2
32	5310-637	WASHER, FLAT, #4, SS	2	2
31	5310-080	WASHER, FLAT, #10, SS	2	2
30	5310-031	WASHER, 1/4 X 5/8 O.D., SS	1	1
29	6145-81153-75	TAPE, PEEL BLADE, CUT TO 5.75"	1	1
28	6146-81164-25	TAPE, PEEL BLADE, CUT TO 4.25"	1	1
27	6146-647	SPRING, HOLD-DOWN, SINOXCEL	1	1
26	6105-066	SPRING COLLAR	1	1
25	4100-636	SPACER, NYLON	1	1
24	4100-632	SHAFT, PEEL BLADE	1	1
23	4100-637	3/8" BOLDEN FEMALE SHAFT, 3" LONG	1	1
22	5081-730	SCR. M5 X 0.8 X 12, SHCS, SS	1	1
21	5081-729	SCR. M6 X 1 X 25, SHCS, SS	1	1
20	5081-728	SCR. M5 X 0.8 X 12, SHCS, SS	2	2
19	5081-727	SCR. M5 X 0.8 X 12, SHCS, SS	2	2
18	5310-602	SCR. M5 X 0.8 X 8, THIN HD, SS	1	1
17	5030-712	SCR. M4 X 0.7 X 8, SOCKET, CLIP PT, SS	1	1
16	6080-711	SCR. M4 X 0.7 X 8, SOCKET, CONE PT, SS	2	2
15	5250-024	SCR. M3 X 0.5 X 4 X 5, SH DR, SOC HD, SS	1	1
14	5151-513	SCR. M2.5 X 5.0, PAN HD, PHIL, SS	3	3
13	4100-604	ROLLER, WEAR ENCODER	1	1
12	5321-220	RETAINING RING, EXTERNAL, S45C, SS	2	2
11	4100-631	PEEL BLADE	1	1
10	5309-315	NUT, LOCK, M5 X 0.8, EXT TOOTH, ZN	2	2
9	6146-612	HOLD-DOWN ARM, L.A. MODE	1	1
8	4100-501	GAP SENSOR ASSEMBLY	1	1
7	4100-630	ENCODER ASSEMBLY	1	1
6	6146-613	COLLAR, SHAFT, SPLT	2	2
5	6146-611	BRUSH, NYLON, 5/16 X 1.50", L	1	1
4	6146-610	BRACKET, BRUSH ATTACHMENT	1	1
3	4100-638	SPACING, SNAP IN	2	2
2	4100-635	ARM, BRUSH EXTENSION	1	1
1	6146-606	ANCHOR, EXTENSION SPRING, 6-32	1	1
ITEM	PART NO.	DESCRIPTION	4100-630R/QTY	4100-630L/QTY

CONFIDENTIAL		UNLESS OTHERWISE SPECIFIED:	FINISH	4100-630
ALL DIMENSIONS ARE IN INCHES UNLESS OTHERWISE SPECIFIED. ALL DIMENSIONS ARE IN MILLIMETERS UNLESS OTHERWISE SPECIFIED. DIMENSIONS IN PARENTHESES ARE FOR INFORMATION ONLY. DIMENSIONS IN PARENTHESES ARE FOR INFORMATION ONLY. DIMENSIONS IN PARENTHESES ARE FOR INFORMATION ONLY.		FINISH	ANNELLER	12/20/09
DRAWN BY: RB		DATE	REVIEW	2/3/10
CHECKED BY: RB		DATE	XX	XX
APPROVED BY: RB		DATE	XX	XX
TITLE		SCALE	PEEL BLADE ASSEMBLY	
NEXT ASSEMBLY		SCALE: 1:2	SHEET 1 OF 4	
MATERIAL		REV	B	4100-630
MATERIAL		REV	RB	A

System Drawings

10.3 System Drawings - Peel Blade Exploded/Wear Items Kit

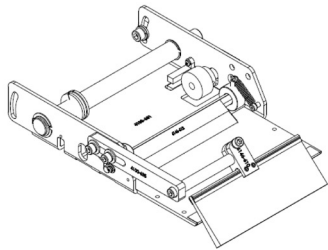

4100-630R

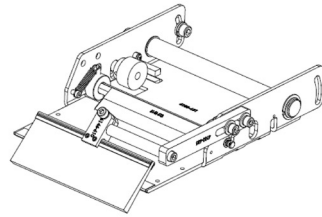

4100-630L

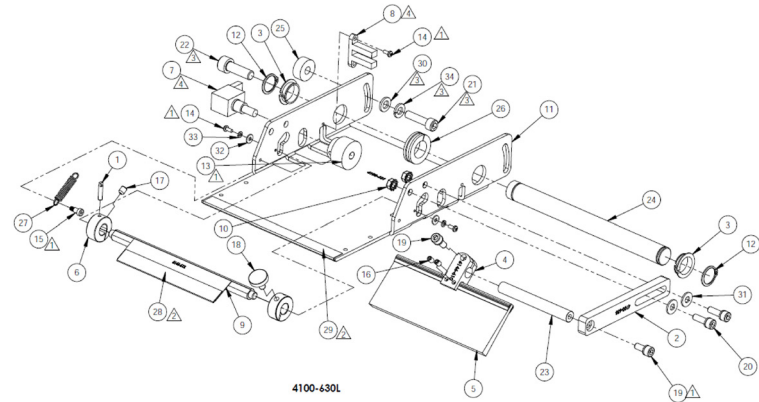

4100-630L

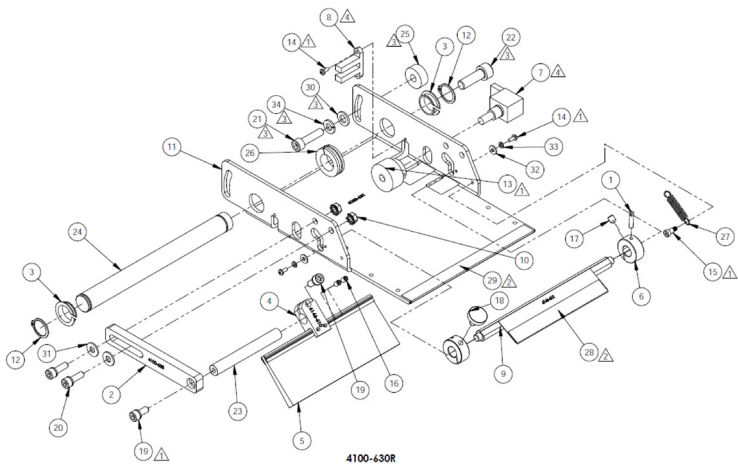

4100-630R

Reference Sheet WEAR ITEMS KIT

PART NO.	DESCRIPTION	QTY.	IMAGE
6146-611	BRUSH, NYLON, 5"W X 1.92"L	1	
4600-607	RETAINER, LABEL CORE	3	
6105-066	SPRING COLLAR	4	
5331-220	SPRING, EXTENSION (DANCER ARM)	2	2.25"L
6146-647	SPRING, EXTENSION (HOLD DOWN)	2	1.00"L
6145-811X4.25	TAPE, PEEL BLADE, CUT TO 4.25"	2	
6145-811X5.75	TAPE, PEEL BLADE, CUT TO 5.75"	2	
4100-604	TIMING BELT, XL, 135 GRVS X .375"W	2	
4600-643	URETHANE SPINDLE	2	

11.0 Declaration of Conformity



DECLARATION OF CONFORMITY

FoxJet, an ITW Company, hereby declares that the equipment specified below has been tested and found compliant to the following directives and standards-

Directives:

- EMC 89/336/ECC
- Low Voltage 73/23/EEC

Equipment Type:

Label Applicator

Model Number:

4100.le

Bruce Castro
Director, Service Parts & Inks
FoxJet, an ITW Company
1 Missouri Research Park Dr.
St. Charles, MO 63304
USA

Standards:

- Conducted Emissions (EN55 011)
- Harmonics (EN 61000-3-2)
- Flicker (EN 61000-3-3)
- Radiated Emissions (EN55 011)
- Electrostatic Discharge (ESD) (EN 61000-4-2)
- Radiated Immunity (EN 61000-4-3)
- Fast Transient Burst (EN 61000-4-4)
- Surges (EN 61000-4-5)
- Conducted Immunity (EN 61000-4-6)
- Power Frequency Magnetic Field (EN 61000-4-8)
- Voltage Dips and Interrupts (EN 61000-4-11)
- Information Technology (EN60950-1:2001)

