

# Operations Manual

## 7100 Series Printer Applicator

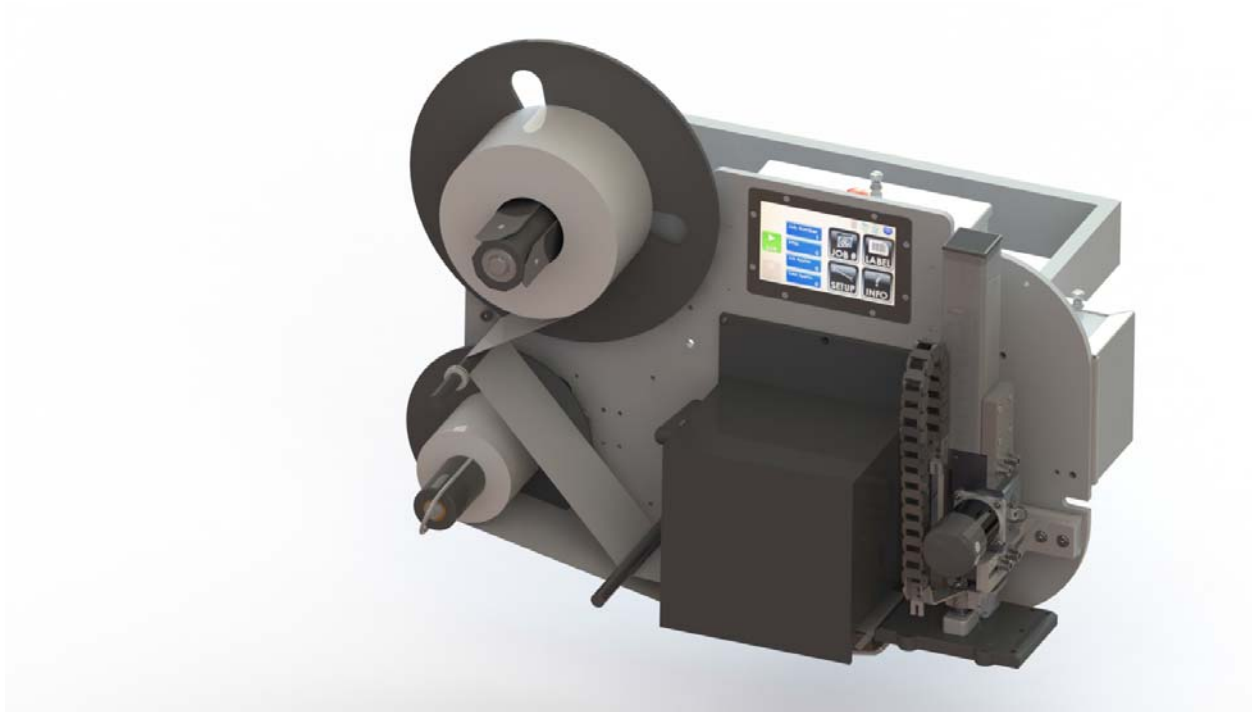

404010FX  
Revision B

# 7100 Series Printer Applicator Operations Manual

---

**404010FX**  
**Revision B**

The information contained in this manual is correct and accurate at the time of its publication. The manufacturer reserves the right to change or alter any information or technical specifications at any time and without notice.

©2021 Illinois Tool Works Inc.  
All rights reserved

## ***7100 Series Printer Applicator***

### **Warranty:**

The Printer Applicator labelers, including all components unless otherwise specified, carry a limited warranty.

For all warranty terms and conditions, contact the manufacturer for a complete copy of the Limited Warranty Statement.

# 7100 Series Printer Applicator

<b>Section 1: Safety</b> .....	<b>1</b>
<b>Section 2: Quick Start</b> .....	<b>3</b>
Step 1: System Orientation .....	4
Step 2: Position and Product Detector .....	6
Step 3: Load Media .....	7
Step 4: Choose Format .....	8
Step 5: Set Rewind Tension .....	9
Step 6: Set Label Generation Mode .....	9
Step 7: Product Delay .....	9
Step 8: Set Actuator Distance Limit .....	10
Step 9: Set Apply Duration .....	10
Step 10: Set Auto Retract .....	11
Step 11: Set the System Online .....	11
<b>Section 3: Maintenance</b> .....	<b>12</b>
Maintenance Schedule Chart .....	12
<b>Section 4: Troubleshooting</b> .....	<b>13</b>
Troubleshooting Chart .....	14
Diagnostics .....	16
Information, Warning, Error, and Diagnostic Codes .....	18

# 7100 Series Printer Applicator

<b>Appendix A: System Specifications</b> .....	<b>20</b>
General Specifications .....	20
Electrical Specifications .....	21
Performance Specifications .....	21
E-TAMP & E-TAMP/BLOW .....	23
E-FASA 10 in. ....	24
E-WASA .....	25
Standard T-Base Stand (CHI, 54" Upright) .....	26
Floor Mount Stand (54" Upright) .....	27
Heavy Duty T-Base Stand (54" Upright) .....	28
Heavy Duty U-Base Stand (54" Upright) .....	29
<b>Appendix B: Application Methods</b> .....	<b>30</b>
E-TAMP Mechanical Setup .....	30
E-TAMP Parameter Setup .....	31
E-TAMP/BLOW Mechanical Setup .....	34
E-TAMP/BLOW Parameter Setup .....	35
High Speed Tamp Mechanical Setup .....	38
High Speed Tamp Parameter Setup .....	39
E-FASA Mechanical Setup .....	42
E-FASA Parameter Setup .....	44
E-WASA Mechanical Setup .....	47
E-WASA Parameter Setup .....	49
<b>Appendix C: Electrical Interface</b> .....	<b>50</b>
<b>Appendix D: Language Support</b> .....	<b>51</b>
<b>Appendix E: Part Numbers</b> .....	<b>52</b>
Service Parts .....	52
Optional Equipment .....	54

## Section 1: Safety

Safety awareness is critical when working with equipment that contains moving parts and extending electric actuators. Please read all warnings and cautions thoroughly before operating this device.

Following is a list of safety symbols and their meanings, which are found throughout this manual. Pay attention to these symbols where they appear in the manual.



Wear safety goggles when performing the procedure described!



Caution or Warning! Denotes possible personal injury and/or damage to the equipment.



Caution or Warning! Denotes possible personal injury and/or equipment damage due to electrical hazard.



NOTE: (Will be followed by a brief comment or explanation.)



ESD protection should be worn when servicing internal printed circuit boards.  
After service to the equipment is completed, replace all protective devices such as grounding cables and covers before operating the equipment.



Caution or Warning! Denotes possible personal injury due to heat.



Caution or Warning! Denotes possible personal injury due to pinching/crushing.



Caution or Warning! Denotes possible personal injury due to pinching/crushing.

**WARNING! Tipping hazard: Tie-down cleats are required to be secured to the ground when using this product on non-flat or uneven surfaces and/or where the center of mass may cause an unsafe condition. (See “Optional Equipment” on page 54 for part numbers.)**

## WARNINGS

- WARNING - Moving parts of this machine can present hazards. Components that cannot be guarded because of loss of functionality are marked with a warning symbol.
- Be aware of the actuator extension distance, and avoid accidental triggering of the photosensor.
- When servicing the unit's electronic assemblies, always remove the power cord from the unit to prevent accidental shock.
- When running for extended periods of time, use caution when accessing the actuator module circuitry. The motor case and motor heatsink can become hot under constant use.
- Wear personal protective equipment, as instructed by your supervisor, when operating or working near this device.
- A connection to a grounded power outlet is required. The power outlet should remain accessible after installation for emergency power disconnect.

## Section 2: Quick Start

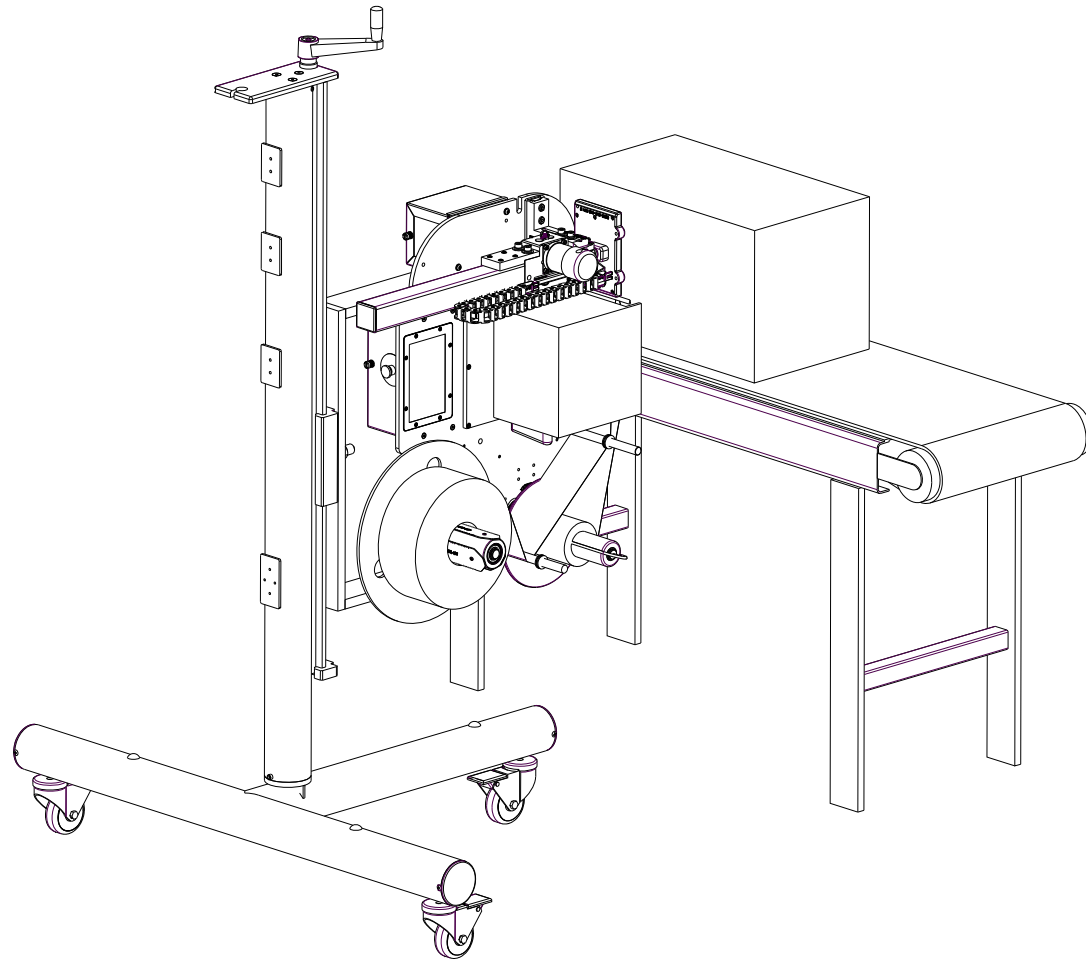

Contents:

- \* Main Applicator
- \* Product Detector Kit
- \* Power Cord
- \* Manual (Digital Copy)



Step 1: System Orientation



**WARNING:** System is top heavy; take care when adjusting roll. Optional Tie-Down Cleats can be used to secure the stand in location (see "Optional Equipment" on page 54).

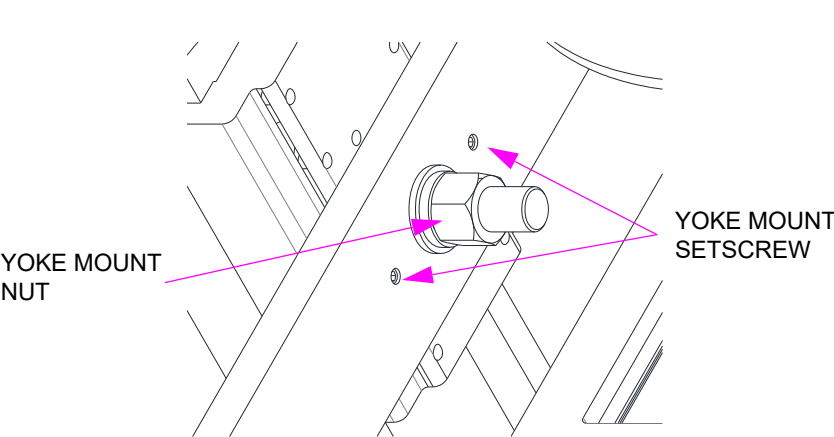

Pitch Adjustment

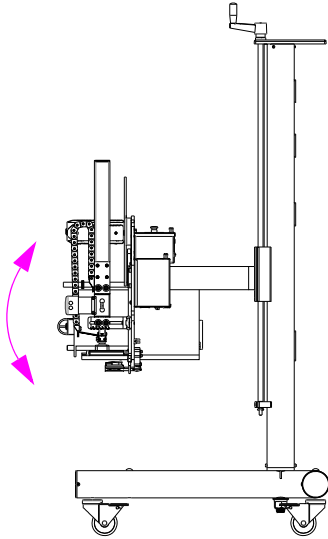
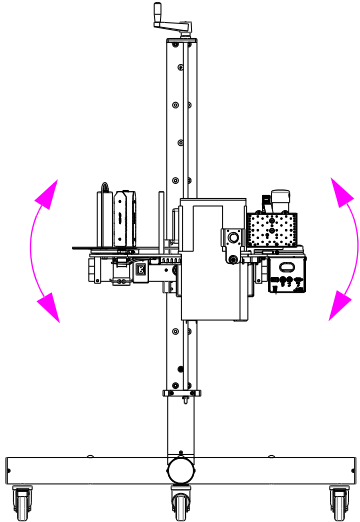

Roll Adjustment

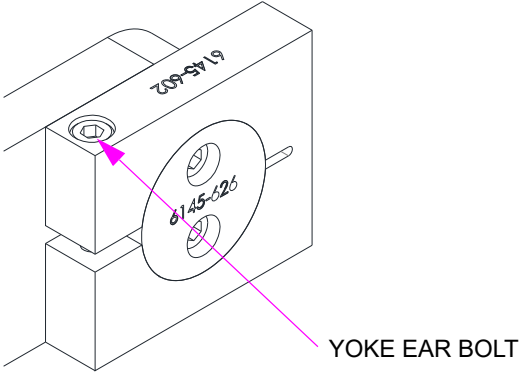

## ORIENTATIONS and SYSTEM ALIGNMENT

Using the Yoke Mount Nut, Yoke Ear Bolts and Yoke Mount Setscrews, adjust the Label Applicator to the desired orientation.

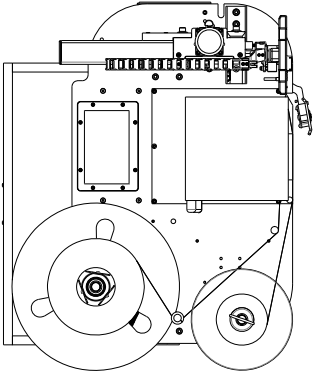

NOSE UP  
(RIGHT HAND)

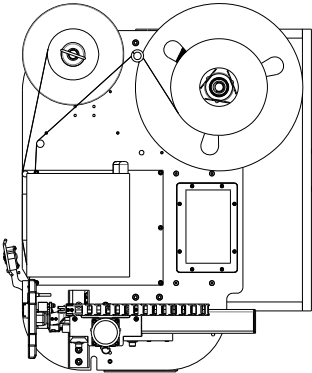
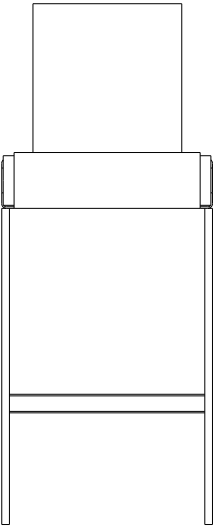

NOSE DOWN  
(RIGHT HAND)

TAMP PAD SHOULD  
LAY FLAT AGAINST  
PRODUCT

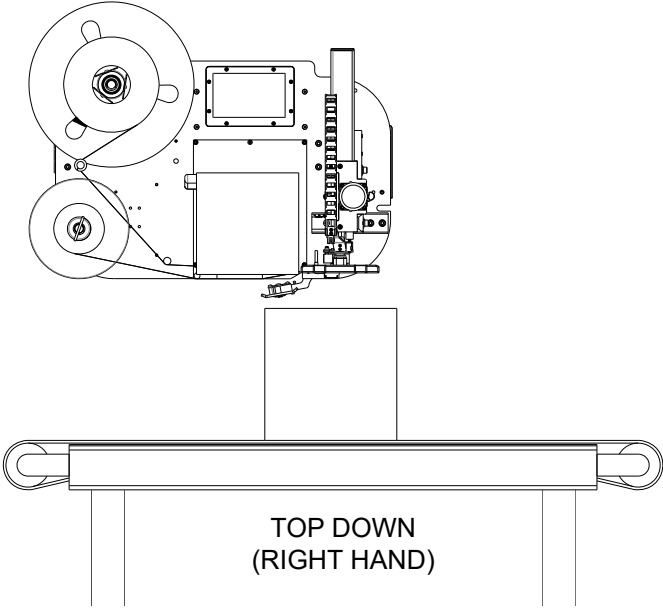
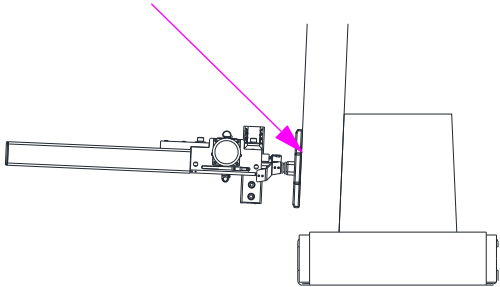

TOP DOWN  
(RIGHT HAND)

SIDE APPLY  
(RIGHT HAND)

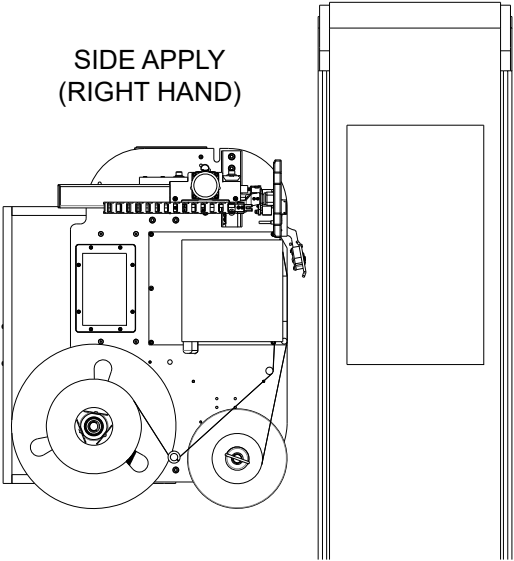

## Step 2: Position and Product Detector

### MACHINE MOUNTING

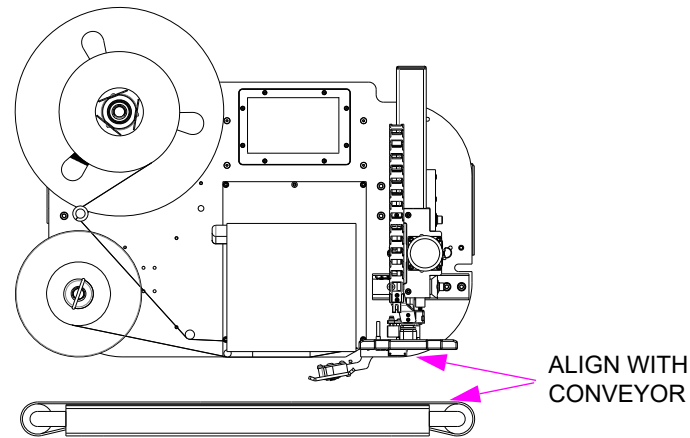
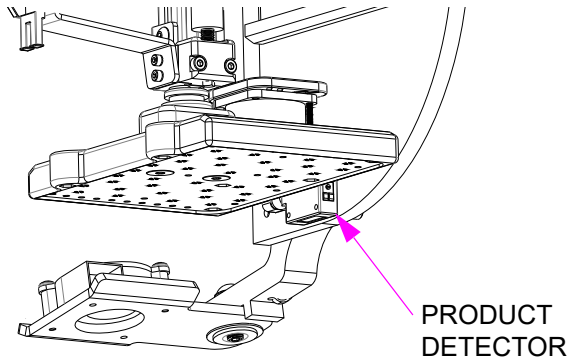

### CONVEYOR MOUNTING

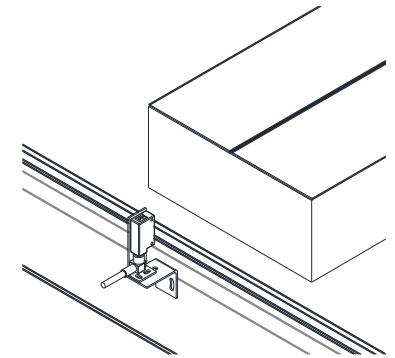

### PRODUCT DETECTOR SETUP

1. To detect product present (Leading Edge), turn Light On/Dark On Selector to L. To detect product absent (Trailing Edge), turn Light On/Dark On Selector to D.
2. Turn Sensitivity Adjuster full counterclockwise.
3. Put a product on the conveyor at the expected distance from product detector during production.
4. Turn Sensitivity Adjuster clockwise until both Power Indicator and Output Indicator are on and solid when product is in front of sensor for Leading Edge, and absence of product for Trailing Edge.
5. Remove product.
6. Verify that detector does not sense movement beyond the far edge of the product. (If so, repeat steps 2 through 6.)

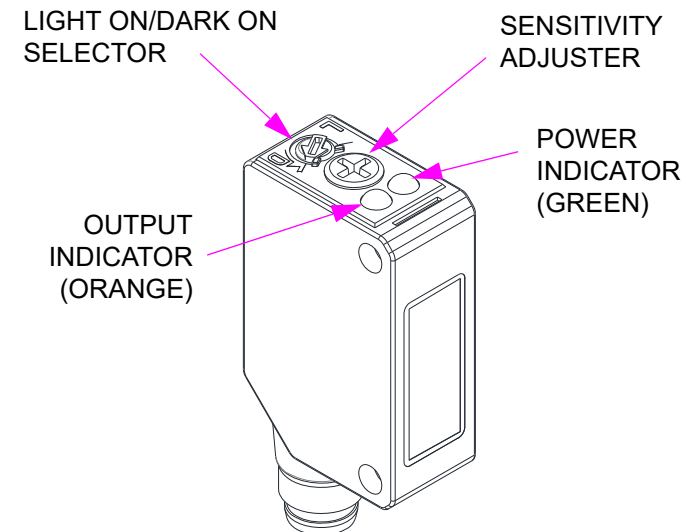

## Step 3: Load Media

1. Push Supply Roll all the way against Unwind Hub.
2. Thread Web around Spindle 1 and under Spindle 2.
3. Thread Web in the engine according to the web path of the engine.
4. Wrap Liner around rewind hub as shown.
5. Insert Rewind Clasp over Liner, and while holding the Liner, turn Rewind until the Liner grips the Rewind.
6. Move Spring Collar 1 to the outside edge of the web. Move Spring Collar 2 to the inside or outside edge of the web, depending on the application.



**CAUTION:** Serious injury could occur to fingers if placed into rewind clasp during operation.

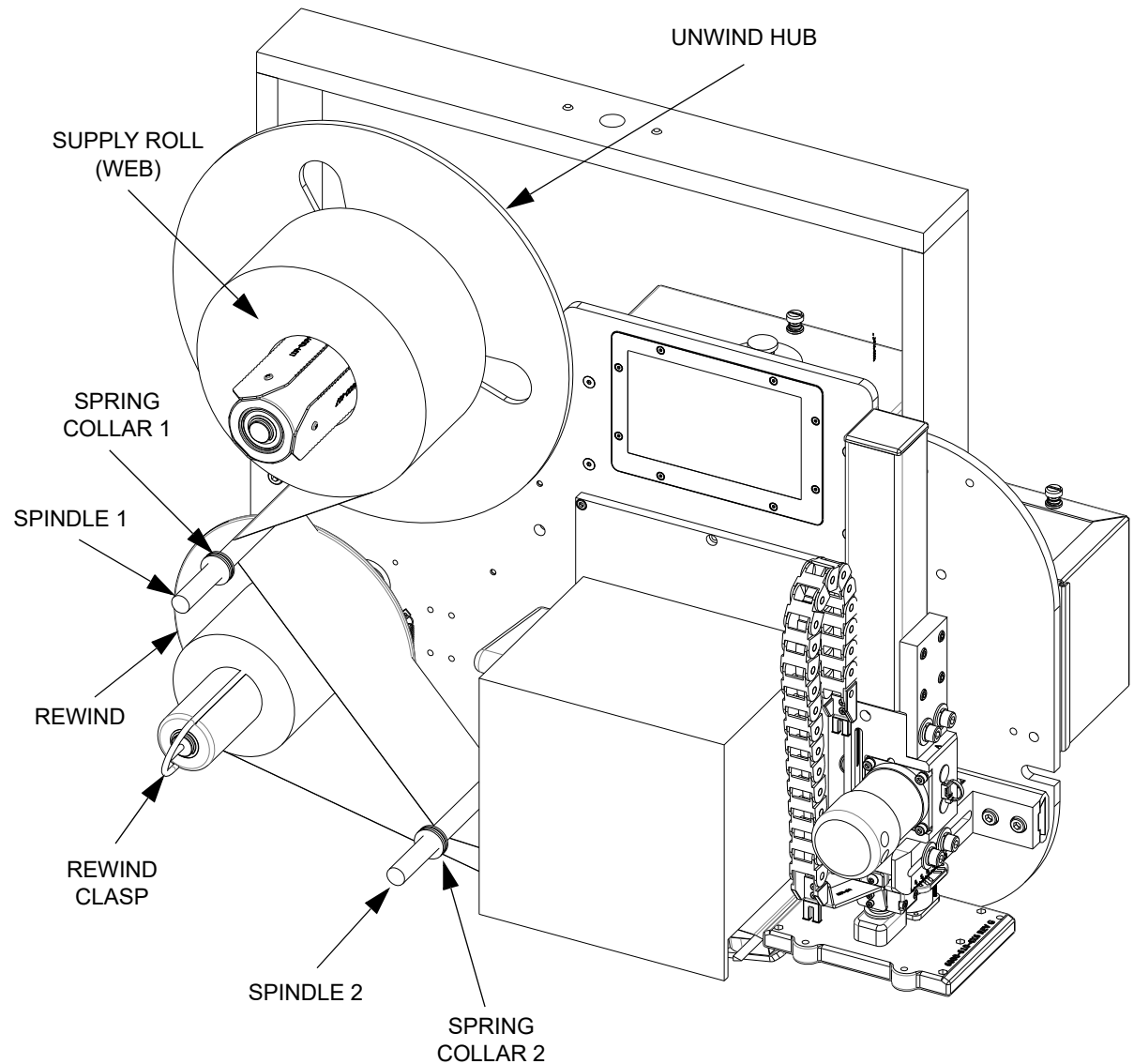



### Step 4: Choose Format

1. Press **LABEL** from the Home Screen.
2. Press **Test**.
3. Select a format from the list by pressing on the name twice.

 **NOTE:** You can also select a format that was previously uploaded in the system by pressing **Recall** from the Label Menu and selecting the format.

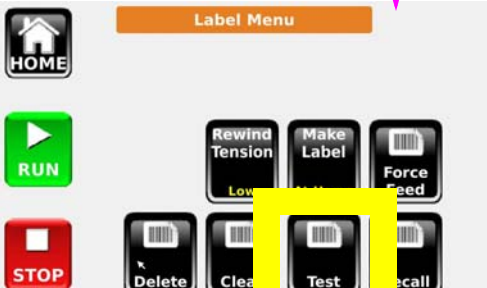
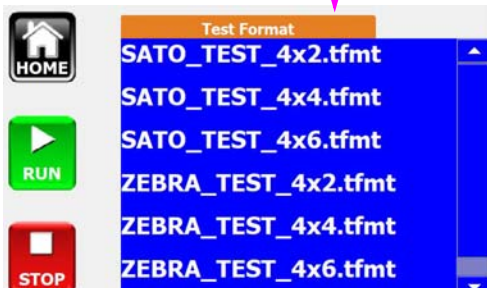
4. Press **Force Feed** button on the Label Menu to check that the format is printed in the correct position on the label.

1. 
2. 
3. 
  - SATO\_TEST\_4x2.tfmt
  - SATO\_TEST\_4x4.tfmt
  - SATO\_TEST\_4x6.tfmt
  - ZEBRA\_TEST\_4x2.tfmt
  - ZEBRA\_TEST\_4x4.tfmt
  - ZEBRA\_TEST\_4x6.tfmt
4. 

### Step 5: Set Rewind Tension

Change **Rewind Tension** in the Label Menu to desired value. This setting will depend on the feed speed, label length and the liner material type (see LABEL MENU setup for the appropriate applicator in Appendix B: Application Methods).



### Step 6: Set Label Generation Mode

Change **Make Label** in Label Menu to desired value. This setting depends on the desired application of when the label should be printed (see LABEL MENU setup for the appropriate applicator in Appendix B: Application Methods).



### Step 7: Product Delay

1. Press **Setup** from the Home Screen, then press **JOB**.
2. Press **Apply Delay**.
3. Set the delay from when the Product Detector triggers to when the applicator applies a label, in milliseconds. Press OK. (See JOB MENU setup for the appropriate applicator in Appendix B: Application Methods.)



## Step 8: Set Actuator Distance Limit



**NOTE:** This Distance Limit is a safety feature used to reduce damage to the machine and product.

1. Press **ACTUATOR SETUP**.
2. Measure the distance from tamp pad face to product face and add 12,7mm to 25,4mm (1/2" to 1").
3. Set **Distance Limit** to the whole number value.
4. Press **Distance Limit Fine** to make distance adjustments in 6mm (1/4") increments.

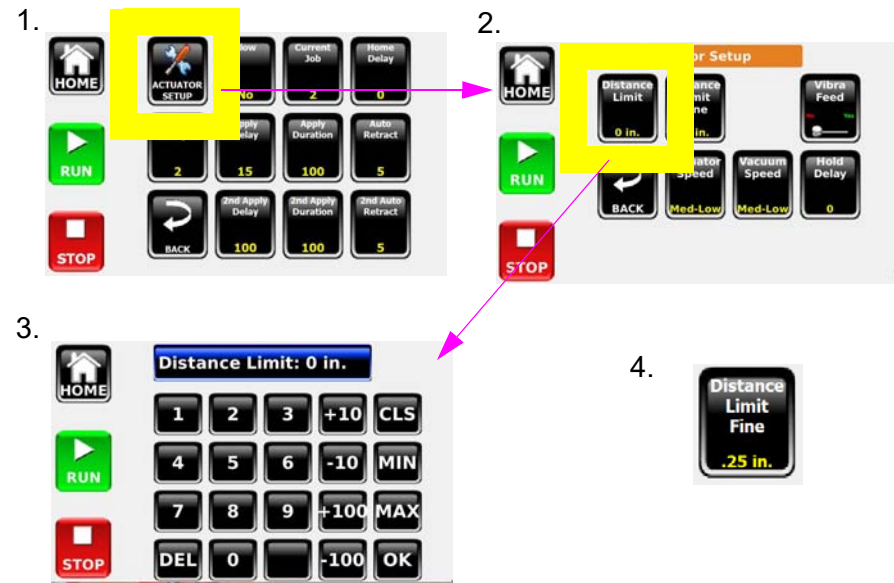

## Step 9: Set Apply Duration



**NOTE:** See Appendix B for more Actuator adjustments

1. Set **Auto Retract** to 0.
2. Place a stationary product in front of the tamp pad.
3. Place system on-line by pressing the green **Run** button.
4. Manually trigger photo trigger with your hand.
5. Adjust **Apply Duration**.
6. Repeat steps 4 and 5 until label adheres to product, but product is not hit too hard.

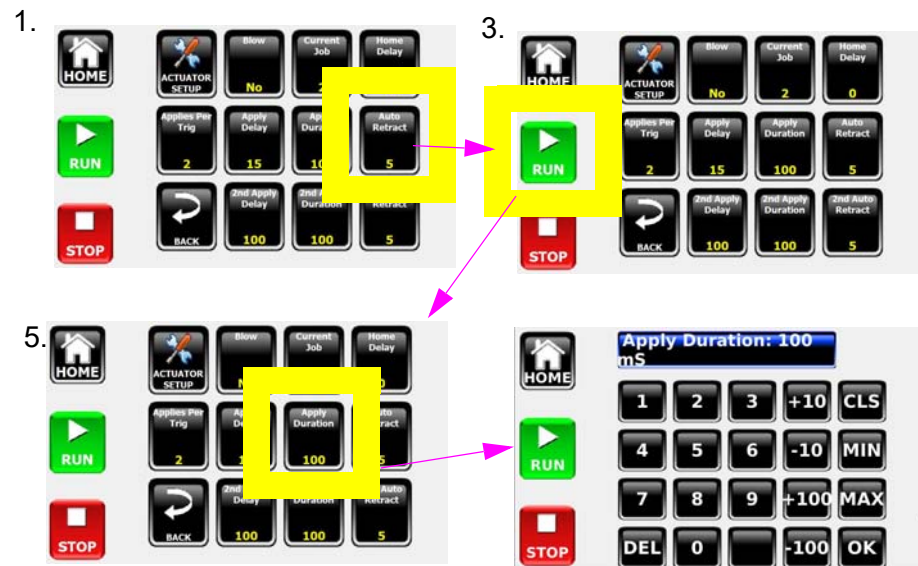

## Step 10: Set Auto Retract



**NOTE:** This step is applicable if an Auto Retract Sensor is installed.

1. Press **Auto Retract**.
2. Set Auto Retract to 5 mS.
3. Place system on-line by pressing the green **RUN** button.
4. Place a product in front of the Actuator and trigger photocell with hand.
5. Adjust **Auto Retract**.
6. Repeat steps 4 and 5 until label adheres to product, but product is not hit too hard.

## Step 11: Set the System Online

Press the **RUN** button from any screen. The system is ready to apply labels when the background turns green.

Press the **STOP** button from any screen to stop the system from applying a label.



**NOTE:** Any change made to the settings are permanently saved when Home is pressed. If Home is not pressed, the setting will be temporary.



## Section 3: Maintenance

### Maintenance Schedule Chart

(See drawings on the following page.)

Action	Daily	Monthly	Annually	Description
Clean Printer Feed Rollers		✓		Use isopropyl alcohol and soft, lint-free cloth to wipe all adhesive and paper dust free.
Replace Printer Feed Rollers *			✓	Follow printer manufacturer's procedures.
Replace Printer Peel Blade *			✓	Follow printer manufacturer's procedures.
Clean Label Present and Auto-Retract Sensors (if installed)	✓			Use isopropyl alcohol and soft, lint-free cloth to wipe all dust and contaminants free.
Clean Label Low Sensor (if present)		✓		Use isopropyl alcohol and soft, lint-free cloth to wipe all dust and contaminants free.
Clean Product Detector Sensor(s)		✓		Use a soft, lint-free cloth to wipe all dust and contaminants free. Be careful not to damage the plastic lens with alcohol-based solvents.
Inspect Rewind Belt		✓		Check for frayed edges and exposed reinforcement fibers.
Replace Rewind Belt *			✓	Remove Rewind disk by taking off E-clip. Keep belt loose by holding up on the spring-loaded belt tensioner. Replace belt and reinstall the Rewind disk.
Replace Unwind Dancer Spring *			✓	Unwind spring can be accessed through the slots of the Unwind disk.
Clean Tamp Pad	✓			Use compressed air and a hard bristle brush to clean any contaminants in the pad face. Isopropyl alcohol can be used to wipe the pad clean. <b>DO NOT SPRAY CHEMICALS INTO THE FANS!</b>
Clean Vacuum and Air Assist Fan	✓			Use clean compressed air (computer cleaner aerosol can) to clean any contaminants in the Air Assist or Vacuum fan. <b>DO NOT SPRAY CHEMICALS INTO THE FANS!</b>
Clean Actuator Rod		✓		Clean the actuator rod with a cleaning cloth. Use a light amount of isopropyl alcohol on cloth to remove build-up. <b>DO NOT USE OIL OR GREASE ON ACTUATOR ROD!</b>
Inspect Actuator Drive Belt		✓		Check for frayed edges and exposed reinforcement fibers.
Replace Actuator Drive Belt and Bearing Pads *			✓	Follow replacement procedures contained with new components.
Clean Baseplate Spindle(s)		✓		Use isopropyl alcohol and soft, lint-free cloth to wipe all dust and contaminants free.
Replace Baseplate Spindle(s) *			✓	Replace by unscrewing the old spindle; replace with new spindle and some service-removable Loctite.

\* Indicates item is sold as part of a service kit. See "Appendix E: Part Numbers" on page 52.

### Section 4: Troubleshooting

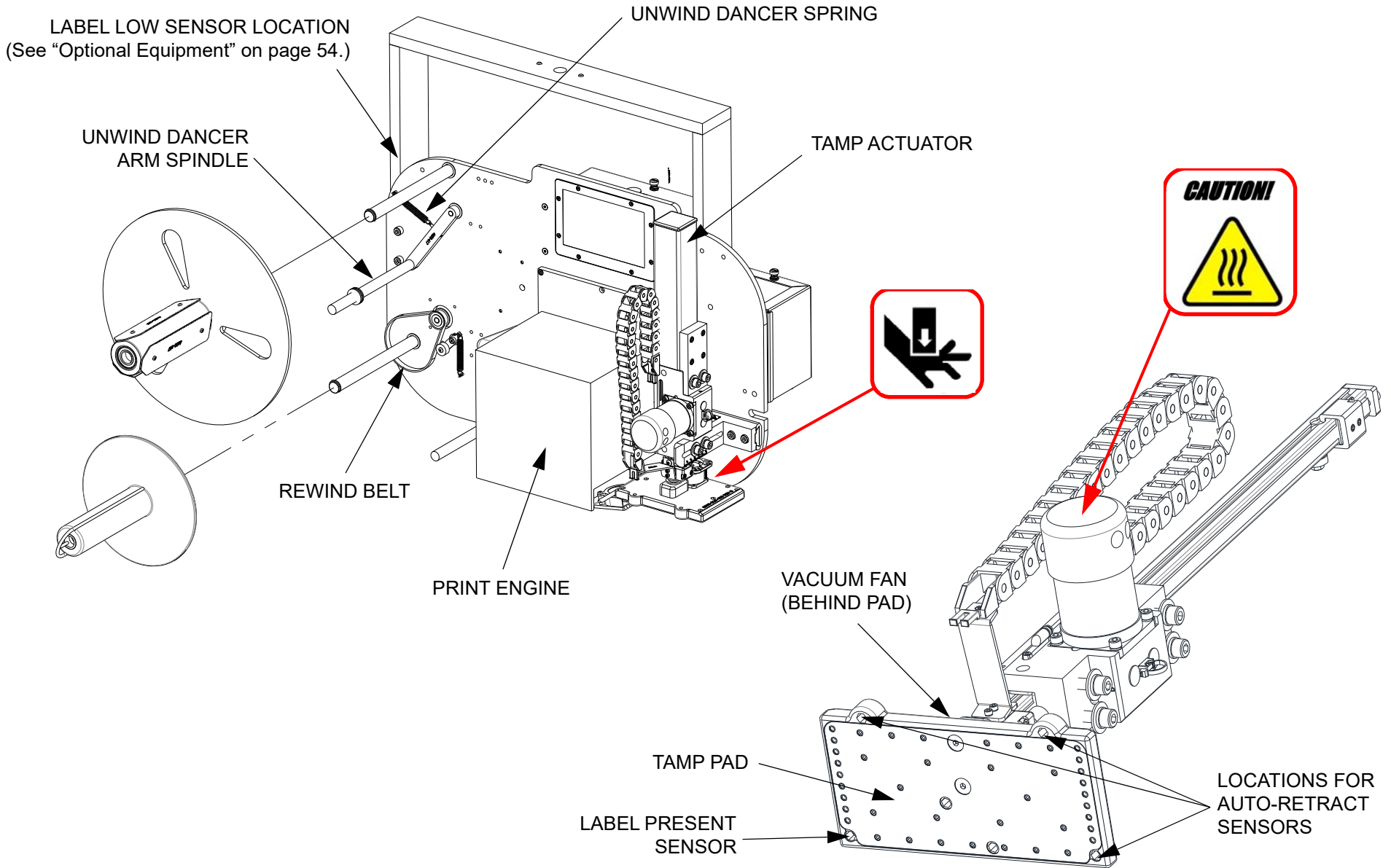

## Troubleshooting Chart

Problem	Possible Cause	Correction
Supply roll is signaling label low too soon	Label Low Sensor position incorrect	Unscrew the label Low Sensor, move it to a position farther away from the unwind supply roll core and screw into position.
	Label Low Sensor malfunction	Refer to “DIAGNOSTICS SCREEN” on page 17 to verify sensor functionality.
Unit will not actuate when product detector is triggered	Unit is off-line or has an error condition	If no errors exist, press RUN button to place unit on-line. If errors exist, determine error type from the display and clear error condition. Attempt to go on-line by pressing the RUN button (this will also check for remaining errors).
Label is on the tamp pad, but Actuator does not fire	Product detector not triggered by product	Refer to “DIAGNOSTICS SCREEN” on page 17 to verify that the product detector can repeatedly detect the product. Adjust sensor as necessary.
	Apply trigger occurred before label was on tamp pad	Increase distance of product detector from tamp pad to allow feeding to complete.
	Actuator malfunction	Refer to “DIAGNOSTICS SCREEN” on page 17 to manually trigger the actuator.
Tamp pad is contacting product with too much force or for too long a duration	Auto-Retract delay time is too long	Decrease the Auto-Retract delay time to start the Actuator return sooner.
Labels are feeding into the edge of the tamp pad	Tamp pad position too low	Set tamp pad to a distance just below the peel blade. See Tamp Pad Adjustments in “Appendix B: Application Methods” on page 30.
	Actuator home sensor position too low	Move the home sensor to a position where the Actuator home is detected later.
Label is not feeding out far enough, or it is feeding too far	Label Pitch/Tear off position requires adjustment	Adjust Label Pitch/Tear off to a higher value for more label overfeed, or less to keep the next label from “tonguing” out and disturbing the label on the pad.
Label is drawn back into the printer	Not enough label presentation	
	Tamp pad height incorrect	Adjust height of pad to be slightly below the edge of the peel blade. This forces the label to “snap” off of the edge of the tamp pad and avoids the label from relaxing back onto the peel blade.
	Vacuum Fan Speed too low	Increase the Vacuum Fan speed to a higher setting. Verify that the pad doesn’t just require cleaning.

## Troubleshooting Chart (continued)

Problem	Possible Cause	Correction
Label is not getting out to the pad, or is falling off	Air Assist Blower is rotated out of the way	Rotate the Air Assist Blower under the printer and aim at the tamp pad.
	Air Assist Blower is damaged	Using a flashlight, check that the blower fan is rotating.
	Vacuum Fan Speed too low	Try increasing the fan speed to the next highest setting. Make sure that the label is aligned with the pad.
	Vacuum Fan is damaged	Using a flashlight, check that the fan blades are rotating. Use the lowest setting to see if there is a stationary blade.
Double label feed regularly or intermittently	Backfeed mode is not set to Backfeed Before	This should be set in the label format and/or locally at the printer.
	Rewind Profile is set too high	This can be adjusted in the Label Menu screen. Select a lower profile.
	Label Present sensor adjustment required	The label present sensor (if installed) could be mounted either too far back from the surface of the tamp pad or too close to (or beyond) the edge of the face surface. Loosen the 7mm jam nut, remove the M8 quick disconnect cable and screw the sensor in/out to find the optimal position.
	Label Present and Auto-Retract Sensor cables are switched at the tamp pad or inside the MCM	Switch the cables inside MCM.
	Tamp pad alignment with printer requires adjustment	See "Appendix B: Application Methods" on page 30 and following.

## Diagnostics

### HEARTBEAT LIGHT

As simple as this indicator is, it can help identify a problem with the circuit boards in the labeler. All boards that contain firmware have a flashing blue LED light that indicates a normal, working module.

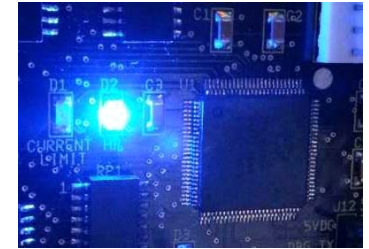

### MCM II DIAGNOSTIC LEDs

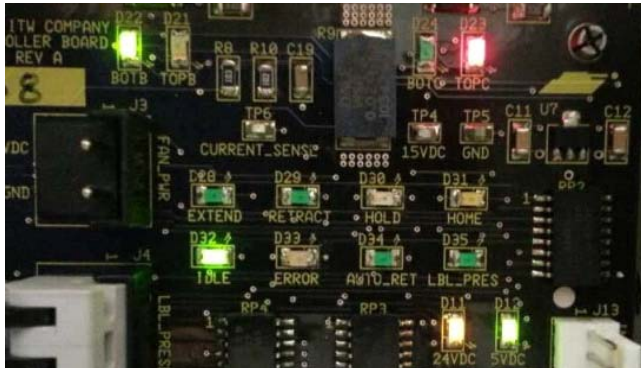

LED	Color	Meaning
BOTA, BOTB, BOTC	Green	Bottom MOSFET Drivers for Phase A, B, C
TOPA, TOPB, TOPC	Red	Top MOSFET Drivers for Phase A, B, C
EXTEND	Green	Actuator is in extension mode
RETRACT	Green	Actuator is in retraction mode
HOLD	Orange	Actuator is holding current position
HOME	Yellow	Actuator is arriving home
IDLE	Green	Actuator is at home and has entered idle current
ERROR	Red	Actuator/MCM has experienced an error
LBL_PRES	Green	Label Present Sensor detects a label on the pad
AUTO_RET	Green	Auto Retract Sensor detects an object near the pad
BLOWR	Yellow	Blow valve output for reverse motor lead
BLOWF	Yellow	Blow valve output for forward motor lead
VAC	Yellow	Vacuum Fan PWM speed voltage to BLDC fan
PD1	Green	Product Detector 1 input
PD2	Green	Product Detector 2 input
AIR	Yellow	Air Assist Fan output voltage
ACTUATOR HOME	Green	Home Sensor input (actuator is in home position)

# 7100 Series Printer Applicator

Press **Info** from the Home Screen, then press **DIAG**.



## DIAGNOSTICS SCREEN

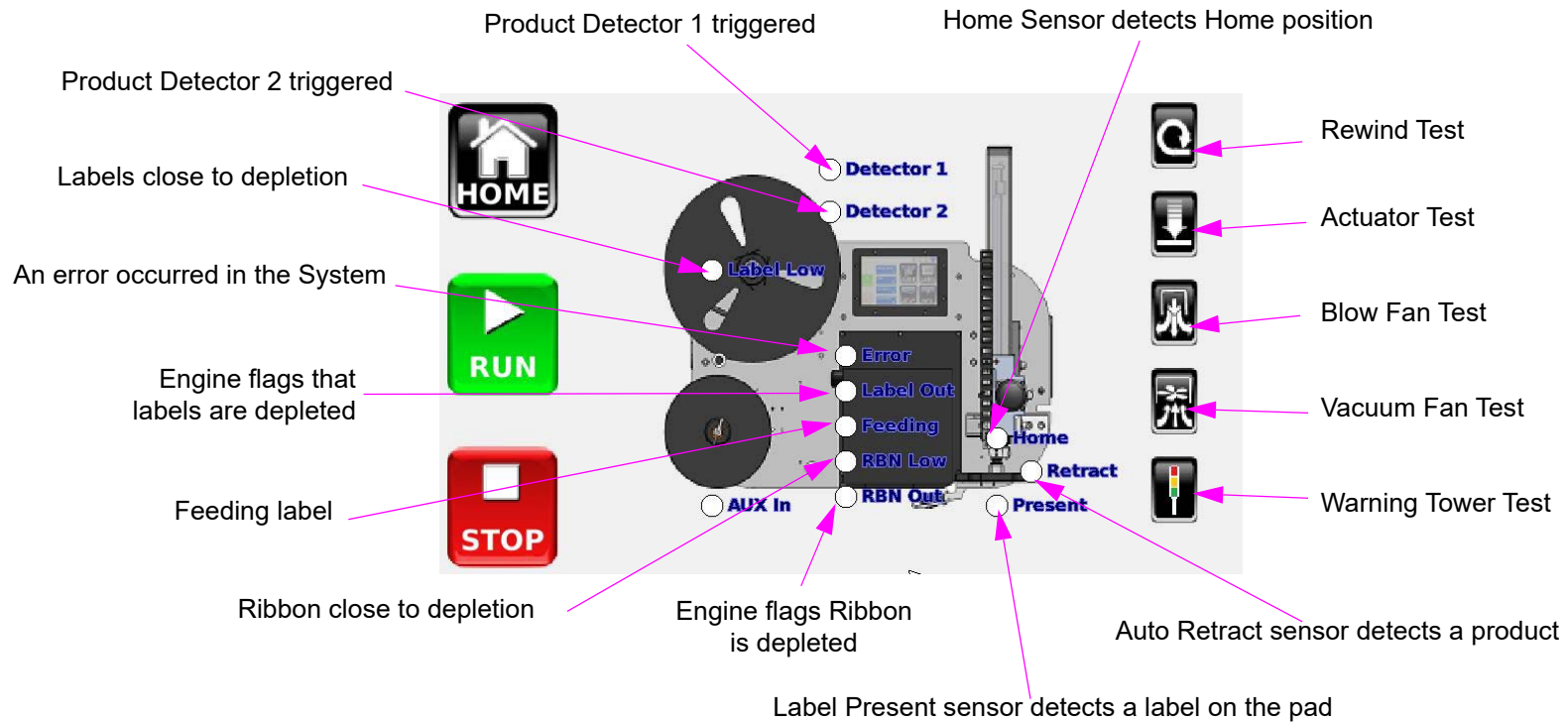

## Information, Warning, Error, and Diagnostic Codes

Message Number	Type	Message	Reason
MSG 1	Error	ACTUATOR NOT HOME	1. Product Delay expired, not home 2. Actuator commanded to return home, but after 5 seconds has not returned 3. Going online, but not home
MSG 2	Error	ACTUATOR AT HOME	Actuator commanded to return home, but it never left home
MSG 3	Error	APPLICATION MODULE	MCM Module has an error
MSG 4	Informational	AUTO RETRACT SENSOR	Upon extending the actuator, the Auto Retract is already detecting
MSG 5	Warning	LABEL LOW	Label Low sensor sees breaks in the signal from the unwind disk and the labels depleting
MSG 6	Error	LABEL OUT	Printer has detected the end of the label supply
MSG 7	Warning	RIBBON LOW	Printer reports the ribbon is at the low level
MSG 8	Error	RIBBON OUT	Printer reports the ribbon is depleted
MSG 11	Error	PRINT ENGINE	Printer reports an error condition
MSG 12	Informational	NO FORMAT	Printer End of Print signal will not toggle, indicating the label has not started printing
MSG 15	Error	LABEL NOT APPLIED	The repeat apply threshold was exceeded
MSG 16	Error	REPEAT LABEL REQUEST	The repeat label threshold was exceeded
MSG 17	Error	REWIND TAKE-UP	The rewind detected a freewheel spin during online take-up of the liner
MSG 18	Error	SECOND APPLY ERROR	In dual apply mode, the first application was not complete before the Second Apply Delay expired. Can't apply second label since the placement would be random. Increase the 2nd Apply Delay.
MSG 19	Warning	SYSTEM NOT READY	System was triggered to apply, but the label was not available to apply. Usually due to demand mode printing not allowing enough time to print or product trigger and no label format in the printer.
MSG 24	Error	REWIND MOTOR FAULT	Motor driver IC reports one or more issues: 1. Disconnected cables 2. Incorrect cable pinout 3. Stalled motor
MSG 26	Warning	LABEL ON PAD	System detects a label on the pad when going online
MSG 30	Informational	FORMAT ISSUE	The format sent to the printer contains control codes that can impact the interface of the labeler and the printer



Message Number	Type	Message	Reason
MSG 35	Informational	NO RETRACT SENSE	Actuator returned home for a reason other than the auto-retract sensor seeing the product
MSG 39	Error	MCM HALL SENSORS	The Hall Effect sensors of the Actuator motor, which determine speed and position of the motor, have an issue. Possible causes are disconnected cabling, damaged connector or damaged motor.
MSG 40	Error	MCM AIR ASSIST	The Air Assist fan output detects a short-circuit. This can be caused by a stalled fan, a damaged fan circuit, or the shorting of the cable leading to the fan.
MSG 41	Error	MCM RETRACT TIMEOUT	The MCM allows up to 10 seconds for the actuator to return to the home position after extension. If it does not return in time, this error is generated.
MSG 42	Error	MCM EXTEND TIMEOUT	The MCM allows up to 10 seconds for the actuator to leave home and travel to the final position. If the actuator exceeds this time, this error is generated.
MSG 43	Error	MCM VACUUM FAN	The MCM monitors the fan output for a short-circuit. This can be caused by a stalled fan, a damaged fan circuit or the shorting of the cable leading to the fan
MSG 44	Informational	PRINT ENGINE BUSY	The print engine has exerted the flow control signal to stop sending data. On the SATO, this can occur when the printer is off-line. On the Zebra, this can occur while the engine is powering up and is not receiving communications.

**NOTE:** For additional messages, errors and warnings, refer to the Troubleshooting Section in the MCA Manual (404012).



## Appendix A: System Specifications

### General Specifications

Category		Parameter
Dimensions (with Yoke)		787mm (31") L x 686mm (27") H x 660mm (26") D
Weight	E-TAMP, E-WASA E-FASA Chi-Stand	54,4 kg (120 lbs) (includes yoke, no stand) 58,9 kg (130 lbs) 43,5 kg (96 lbs)
Accuracy	E-TAMP, E-WASA, E-FASA, E-TAMP/BLOW	±1,6mm (±0.06") ±2,4mm (±0.09")
Certifications		CE, CSA, FCC approved, Listed (UL 60950)
Supply Roll Capacity		355,6mm (14") OD
Core		76,2mm (3") ID
Label Length		12,7mm (0.5") Min. to 355,6mm (14") Max.
Label Width		12,7mm (0.5") Min. to 165,1mm (6.5") Max.
Product Rate	E-TAMP E-TAMP/BLOW E-FASA E-WASA	120 PPM Max. 55 PPM Max. Single Apply: 52 PPM Max. Dual Apply: 28 PPM Max. Dependent on label length, print speed and product spacing
Line Speed	E-TAMP, E-TAMP/BLOW E-FASA E-WASA HIGH SPEED TAMP	76 cm/s (150 FPM) Max. 38 cm/s (75 FPM) Max. 63 cm/s (125 FPM) Max. 150+ cm/s (300+ FPM) Max.
Temperature		5°C - 40°C (41°F - 104°F)
Humidity		10 to 85% Relative Humidity, Non-Condensing

**NOTE:** PPM refers to Products Per Minute.

**NOTE:** Labels 1" x 1" and smaller require testing to ensure quality placement and speed.

## Electrical Specifications

Category	Nominal	Minimum	Maximum
AC Voltage Supply	110 VAC/4A 240 VAC/2A 50/60 Hz	85 VAC 47 Hz	264 VAC 63 Hz
Product Detector	Low: 0 to 3 VDC High: 3 to 5 VDC Supplies 24 VDC	0 VDC	24 VDC
Product Detector Pulse Width	10 mS	1 mS	Infinite
Auxiliary Output Warning Tower	0 and 24 VDC 1 Amp sinking	0 VDC 0 mA	24 VDC 3 Amps sinking
Discrete Inputs (Optional)	Low: 0 to 10 VDC High: 10 to 24 VDC	0 VDC	26 VDC
Discrete Input Pulse Width Detection	10 mS	1 mS	Infinite
Discrete Outputs (Optional)	0 - 24 V AC/DC at 150 mA	0 V AC/DC, 13 ohms	30 V AC/DC at 400 mA

## Performance Specifications

10 or 20 in. E-TAMP Labeler Application	Label Size	Stroke Distance (Baseplate edge to product)	PPM Maximum
Side Orientation (Nose-Down)	101,6mm x 50,8mm (4" x 2"), 12 ips	101,6mm (4"), HIGH Actuator Profile	85 PPM
Side Orientation (Nose-Down)	101,6mm x 50,8mm (4" x 2"), 12 ips	76,2mm (3"), HIGH Actuator Profile	94 PPM
Side Orientation (Nose-Down)	101,6mm x 50,8mm (4" x 2"), 12 ips	38,1mm (1.5"), HIGH Actuator Profile	102 PPM

<b>10 in. E-FASA Labeler Application</b>	<b>Label Size</b>	<b>Stroke Distance (Baseplate edge to product)</b>	<b>PPM Maximum</b>
Dual Panels - Front & Side	101,6mm x 50,8mm (4" x 2"), 8 ips	114,3mm (4.5"), HIGH Actuator Profile	28 PPM
Dual Panels - Side & Rear	101,6mm x 50,8mm (4" x 2"), 8 ips	114,3mm (4.5"), HIGH Actuator Profile	24 PPM
Single Panel - Front Only	101,6mm x 50,8mm (4" x 2"), 8 ips	114,3mm (4.5"), HIGH Actuator Profile	52 PPM
Single Panel - Rear Only	101,6mm x 50,8mm (4" x 2"), 8 ips	114,3mm (4.5"), HIGH Actuator Profile	46 PPM
Dual Panels - Front & Side	101,6mm x 152,4mm (4" x 6"), 8 ips	114,3mm (4.5"), HIGH Actuator Profile	18 PPM
Dual Panels - Side & Rear	101,6mm x 152,4mm (4" x 6"), 8 ips	114,3mm (4.5"), HIGH Actuator Profile	16 PPM
Single Panel - Front Only	101,6mm x 152,4mm (4" x 6"), 8 ips	114,3mm (4.5"), HIGH Actuator Profile	44 PPM
Single Panel - Rear Only	101,6mm x 152,4mm (4" x 6"), 8 ips	114,3mm (4.5"), HIGH Actuator Profile	40 PPM

<b>20 in. E-FASA Labeler Application</b>	<b>Label Size</b>	<b>Stroke Distance (Baseplate edge to product)</b>	<b>PPM Maximum</b>
Dual Panels - Front & Side	101,6mm x 152,4mm (4" x 6"), 8 ips	355,6mm (14"), MED-LOW Actuator Profile	10 PPM
Dual Panels - Side & Rear	101,6mm x 152,4mm (4" x 6"), 8 ips	355,6mm (14"), MED-LOW Actuator Profile	12 PPM
Single Panel - Front Only	101,6mm x 152,4mm (4" x 6"), 8 ips	355,6mm (14"), MED-LOW Actuator Profile	26 PPM
Single Panel - Rear Only	101,6mm x 152,4mm (4" x 6"), 8 ips	355,6mm (14"), MED-LOW Actuator Profile	24 PPM

<b>E-WASA Labeler Application</b>	<b>PPM Maximum</b>
152,4mm (6") Length WASA, 8 ips	11 PPM
203,2mm (8") Length WASA, 8 ips	10 PPM
254mm (10") Length WASA, 8 ips	9 PPM
304,8mm (12") Length WASA, 8 ips	8 PPM

### E-TAMP & E-TAMP/BLOW

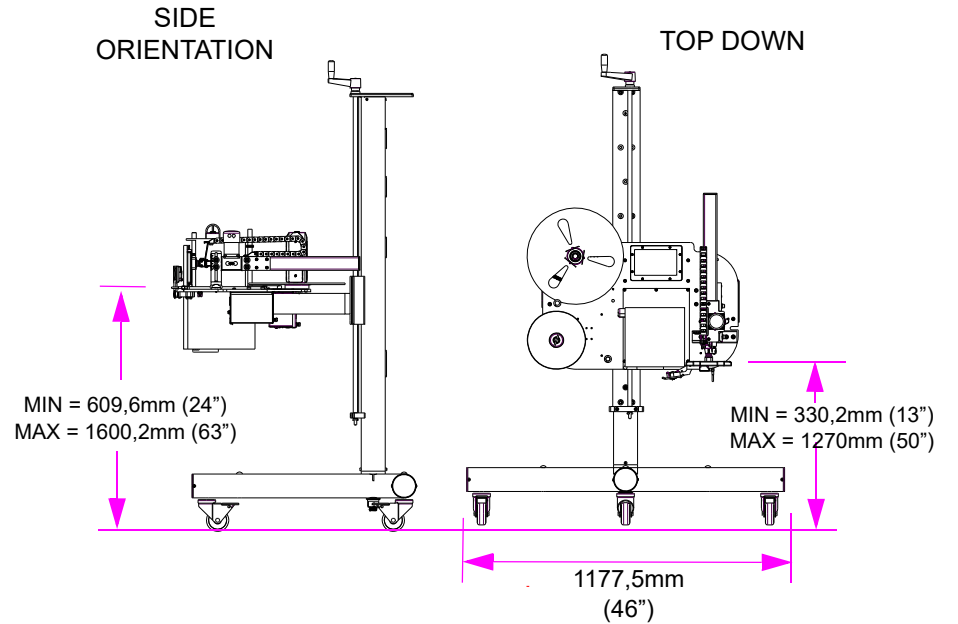
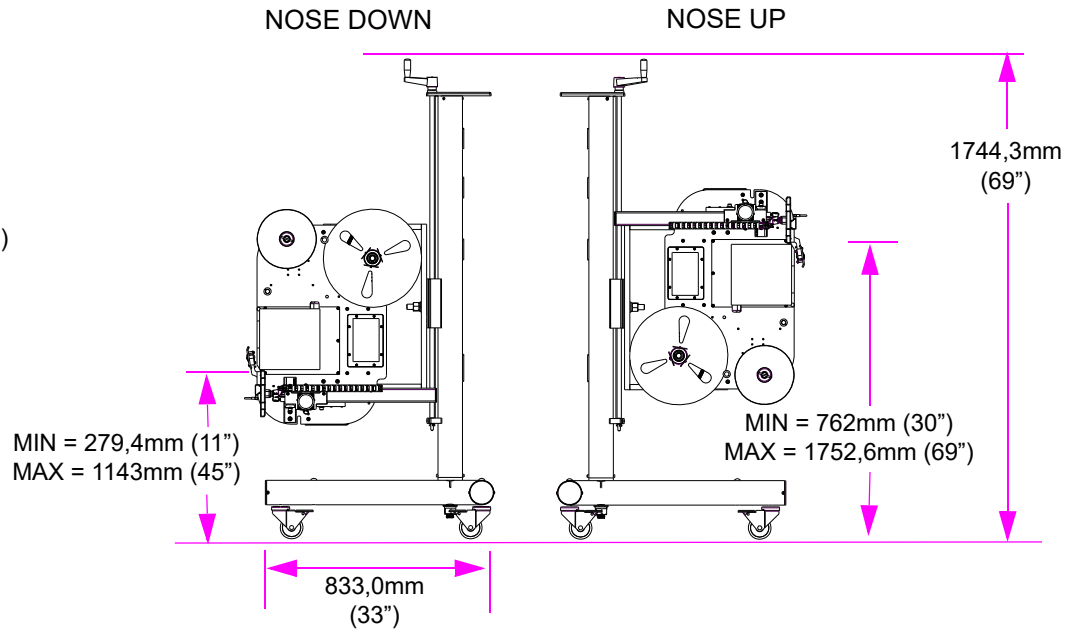
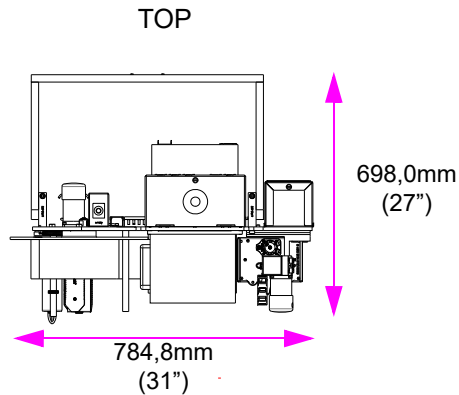
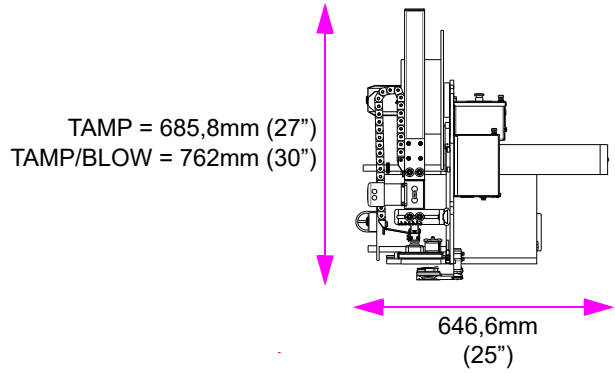
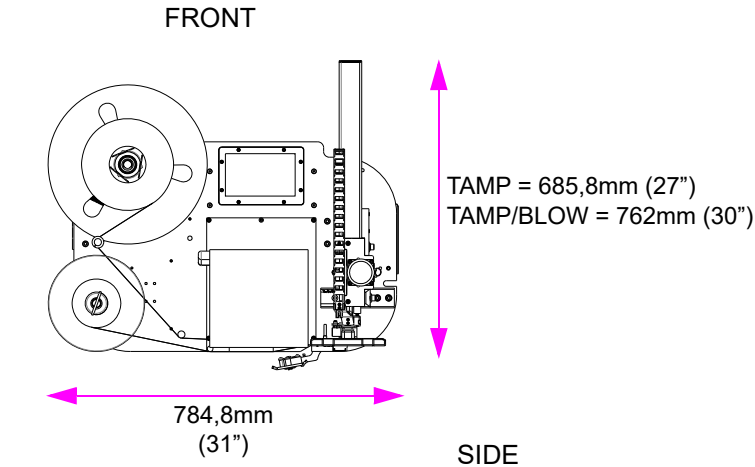

# 7100 Series Printer Applicator

## E-FASA 10 in.

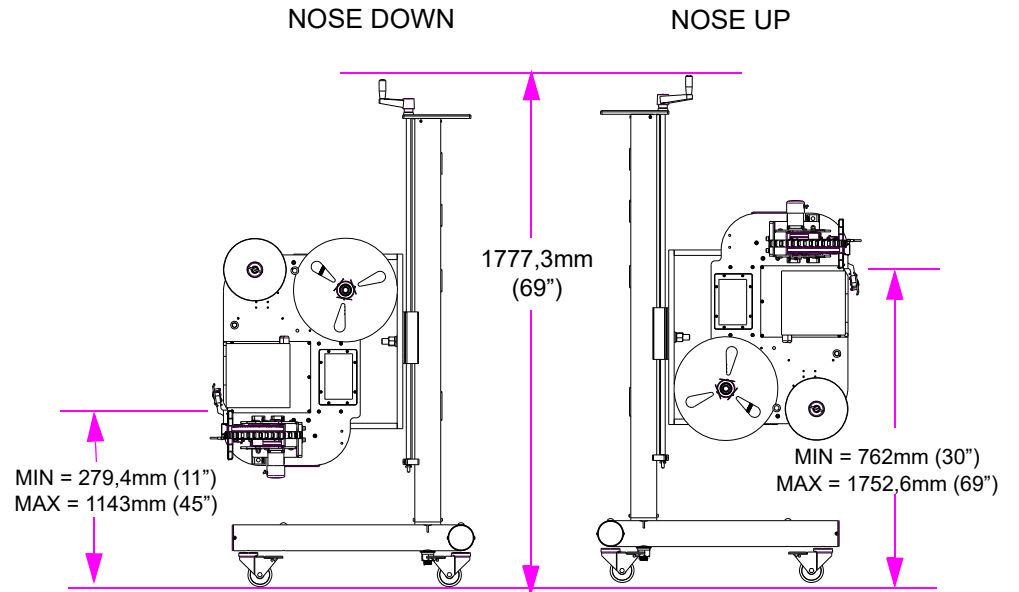
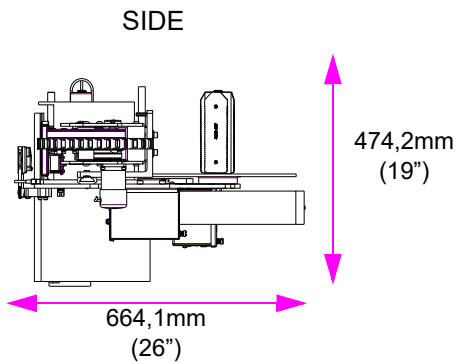
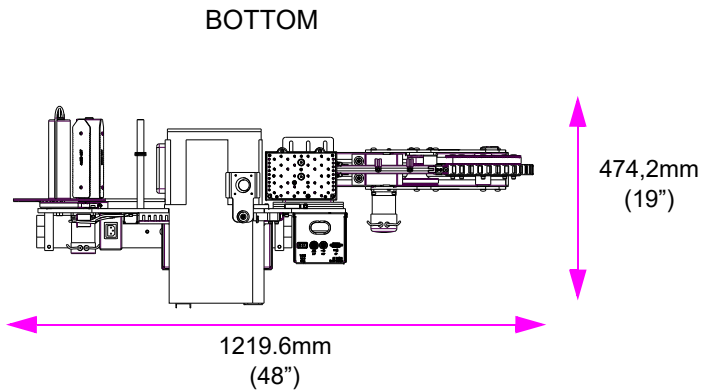
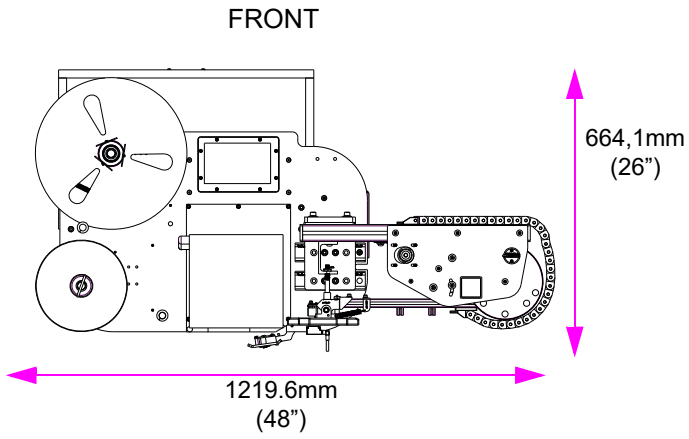

### SIDE ORIENTATION

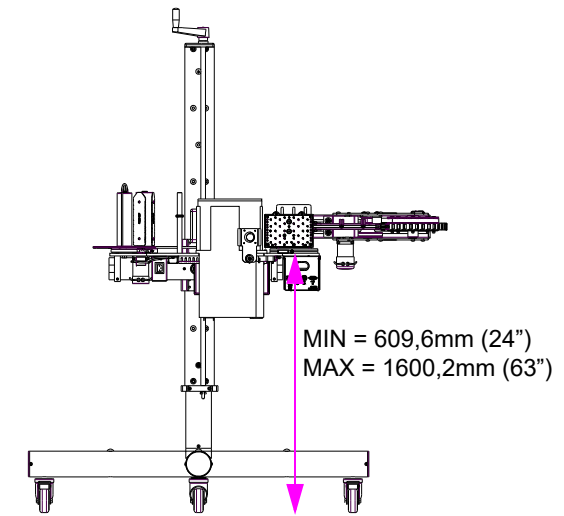

## E-WASA

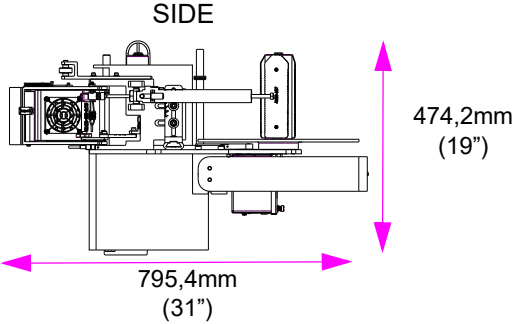
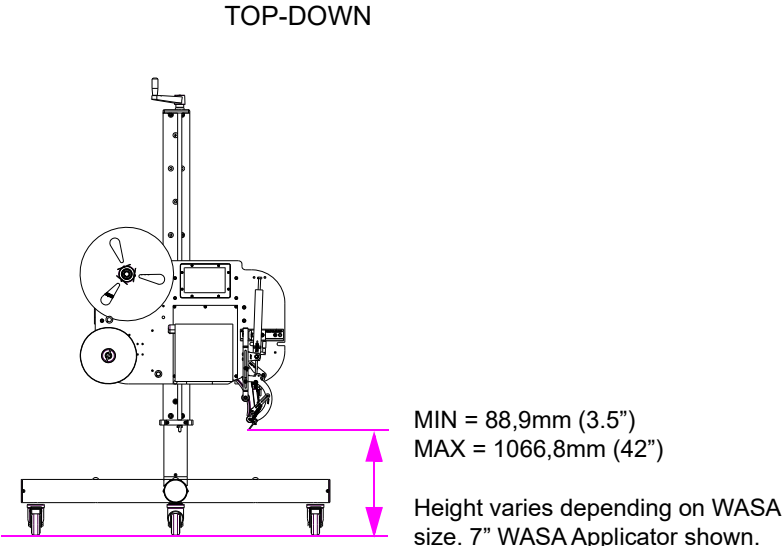
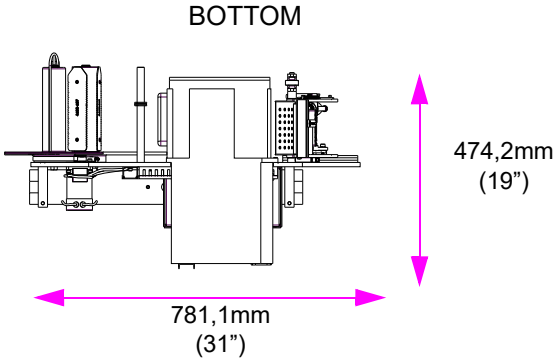
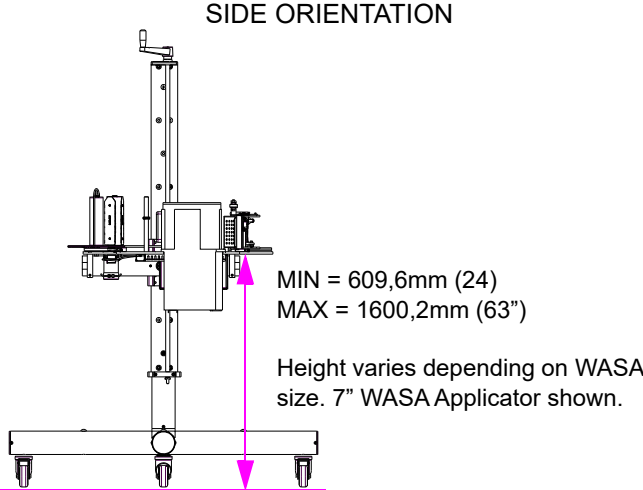
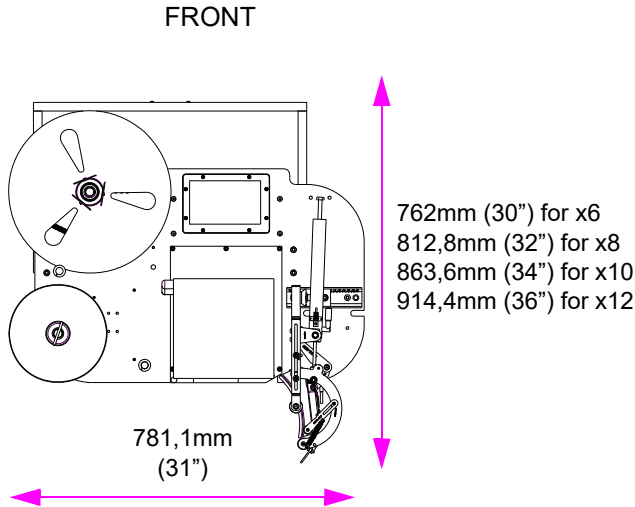

Standard T-Base Stand (CHI, 54" Upright)

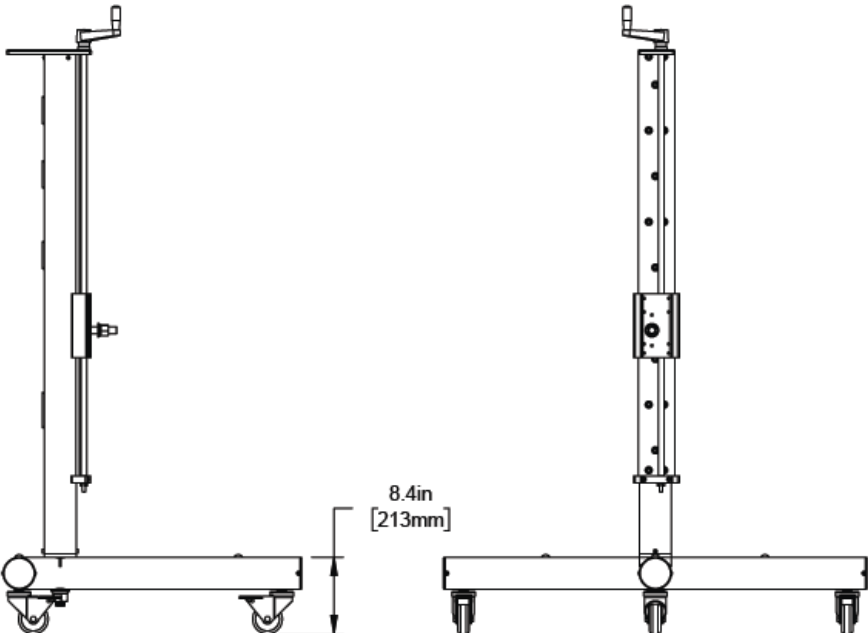
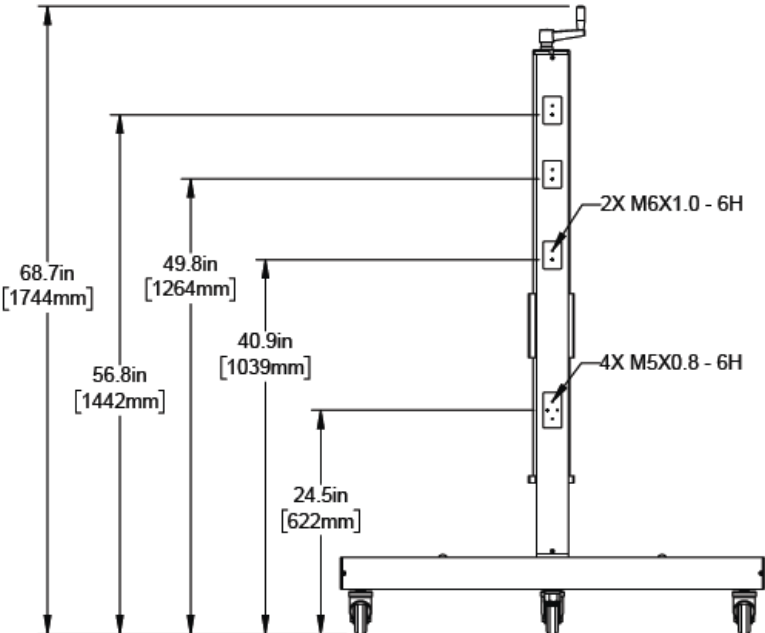
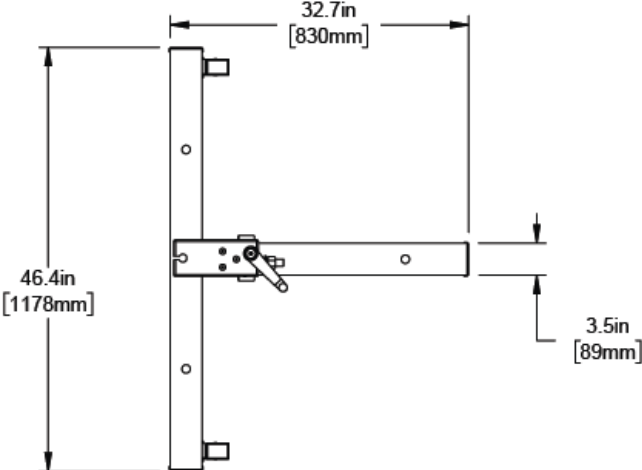

# 7100 Series Printer Applicator

## Floor Mount Stand (54" Upright)

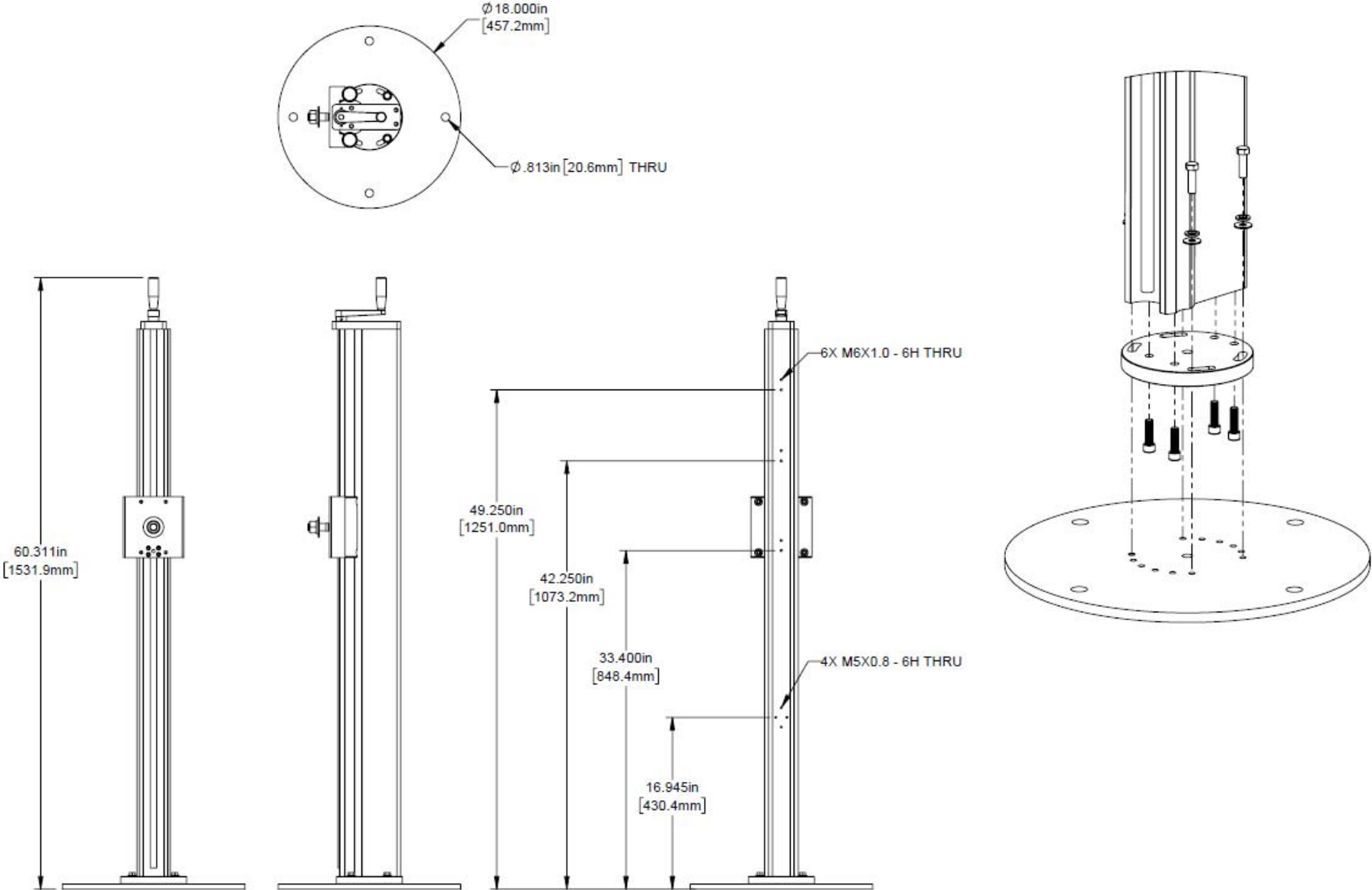



# 7100 Series Printer Applicator

## Heavy Duty T-Base Stand (54" Upright)

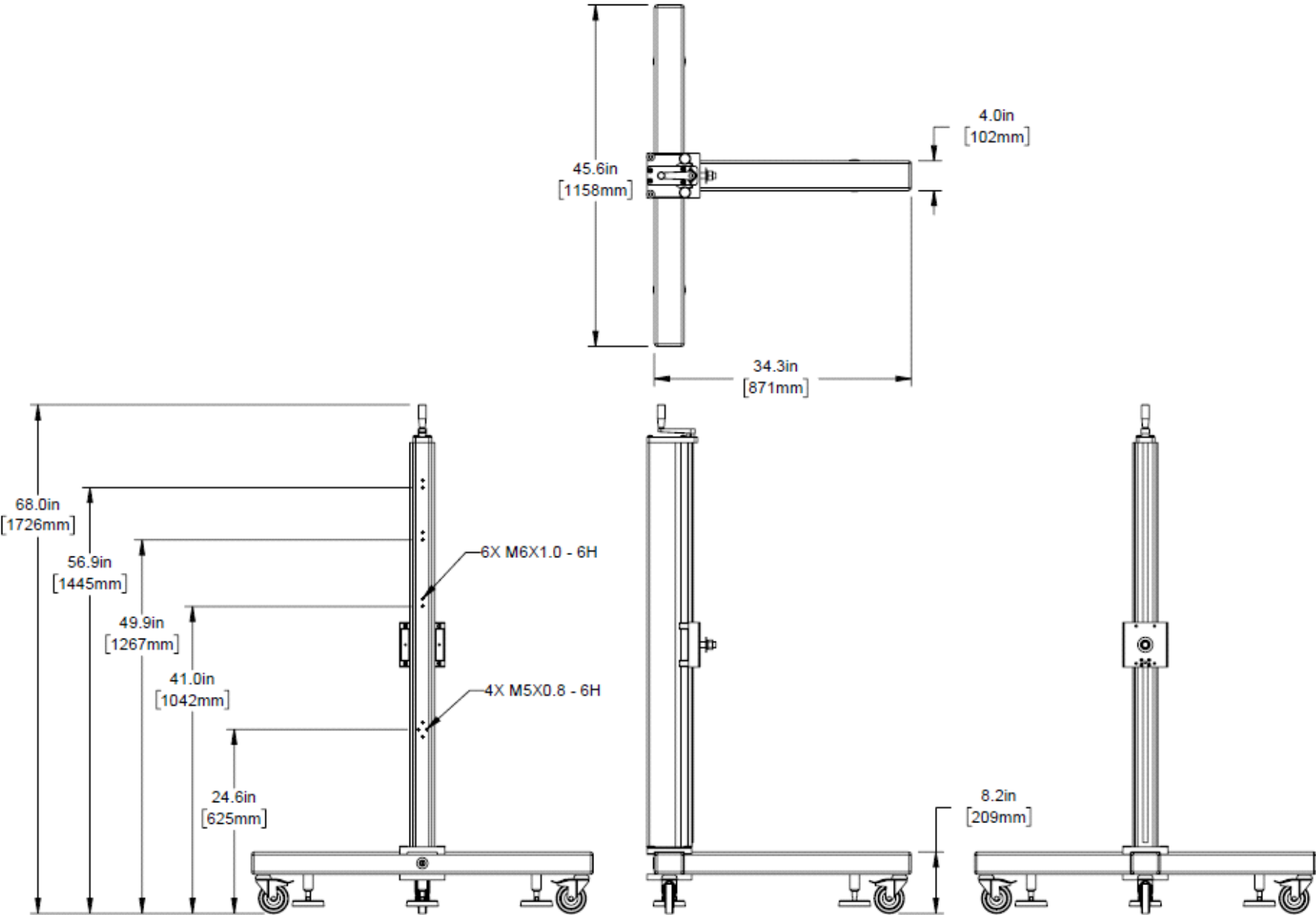

# 7100 Series Printer Applicator

## Heavy Duty U-Base Stand (54" Upright)

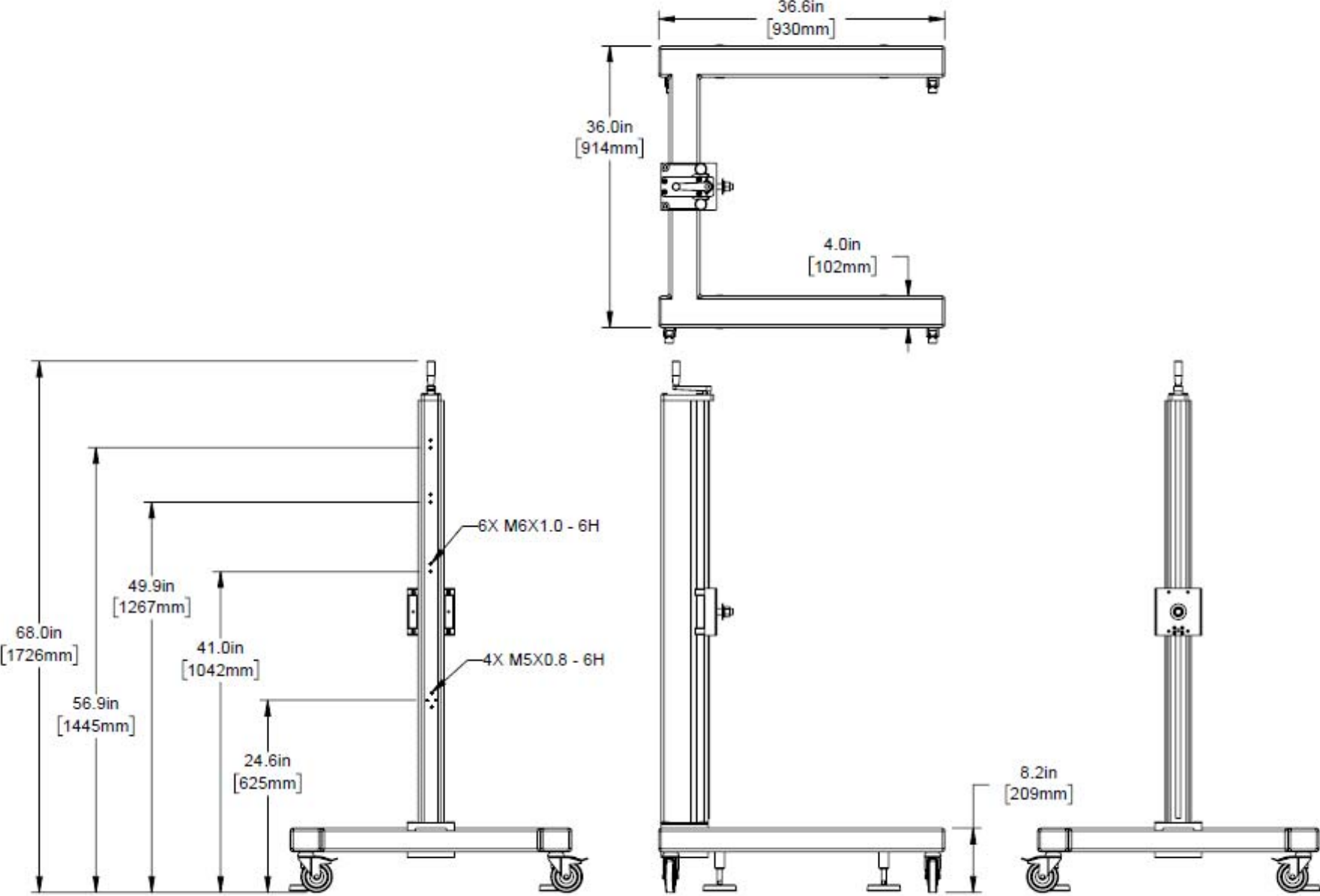

## Appendix B: Application Methods

### E-TAMP Mechanical Setup

#### ALIGN TO PEEL BLADE

1. Loosen both screws on the dovetail slider (A).
2. Slide actuator assembly toward and away from peel blade until there is approximately 3,2mm (1/8") gap.
3. Tighten both screws (A).

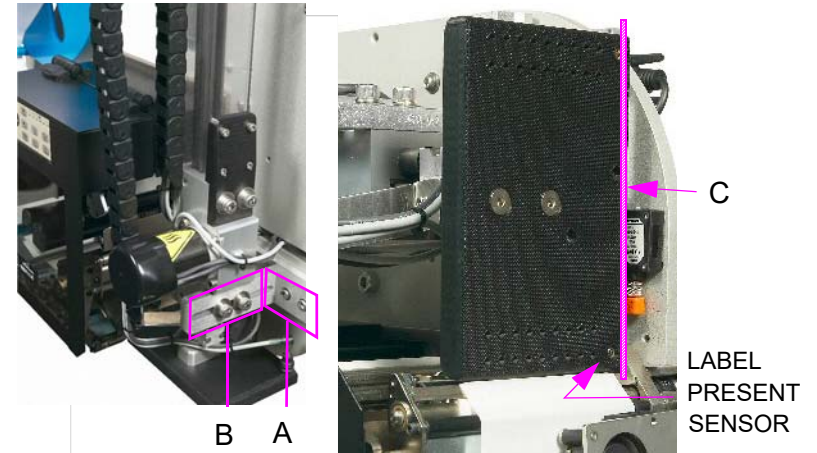

#### ALIGN LABEL WITH TAMP PAD

1. Loosen both screws on the tamp actuator L-bracket (B).
2. Slide the actuator assembly toward and away from the baseplate until the label present sensor will be covered by a fed label.
3. Tighten both screws on the tamp actuator L-bracket (B).

#### ALIGN TAMP PAD HEIGHT

1. Loosen the jam screw on the actuator rod.
2. Adjust the bumper height by turning the bumper so that the face of the peel blade is 1,6mm (1/16") **BEYOND** the peel blade.
3. Power on the Label Applicator to verify tamp pad home position.
4. Tighten the jam screw.

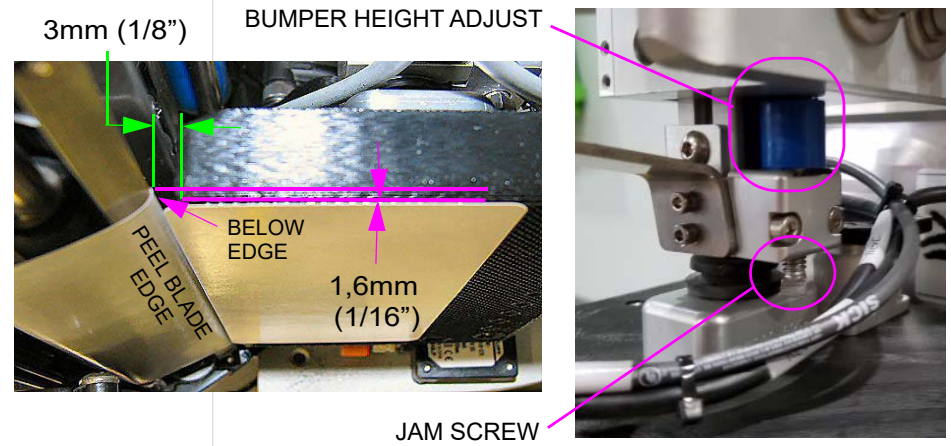

## E-TAMP Parameter Setup

E-TAMP applications allow the label to be placed on the Top, Side or Bottom of a product. Typically, these are applying only one label to a product, but two can be applied as well.

**LABEL MENU** - Enter LABEL Menu from the Home Screen.

Sets the amount of tension applied to the rewind on a print cycle. Set lower for print speeds less than 6 ips or labels shorter than 101,6mm (4”).

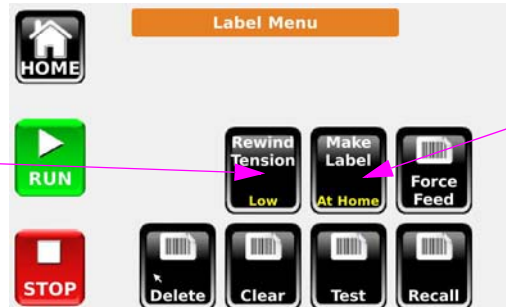

Determines the label generation mode. For slow applications, like pallets, make this **P1 Detect**. This will reduce the time the label adhesive is exposed to air and drying. For highest throughput, use **At Home**. Use **P2 Detect** for the highest accuracy (by using two detectors) when feed on demand is required. **Then Apply** prints a label when actuator is at Home position, then applies immediately.

**SYSTEM MENU** - Enter SYSTEM Menu from the Setup Screen.

Sets the rewind motor direction.

Set to the length of the actuator.

Sets the direction of the Actuator motor. This setting matches the A/B configuration of the actuator.



**E-Tamp** will be chosen for this application.

**Yes** will offset the label placement from the front. If the product lengths vary, and the label needs to be placed off of the trailing edge of the product, set to **No**.

## SMART MENU - Enter SMART Menu from the Setup Screen.

Determines if the system is being used with the optional Label Present sensor.

Determines how many times the label will be printed without an application. The available options are **1**, **2**, **3** and **Infinite**. To ensure a 1 Label to 1 Product match, set this to 1.

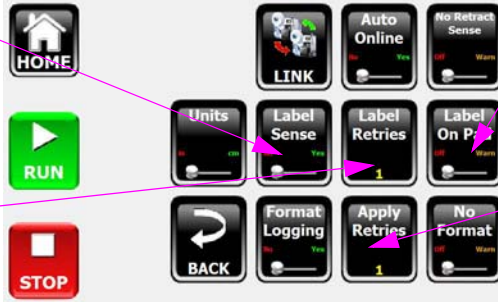

Provides a warning if the system is online with a prior label on the tamp pad. Helps avoid a potential label to product mismatch.

Determines how many times the system will attempt to apply the same label. The available options are **1**, **2**, **3** and **Infinite**. To ensure a 1 Label to 1 Product match, set this to 1.

## SETUP/JOB MENU - Enter JOB Menu from the Setup Screen.

Keep as small as possible by locating the product sensor as close to the peel blade as possible. Exception - if print on demand is used.

Controls the extension stroke time. Set Auto-Retract to zero to properly adjust this time, then re-enable Auto Retract.

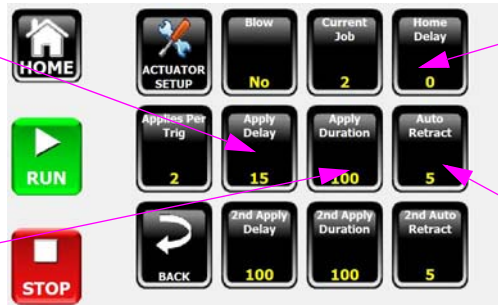

Most E-Tamp applications will not need much Home Delay. Large label sizes will benefit with a minimal delay of 20 to 100 mS.

If installed, the Auto-Retract (AR) time depends on the Actuator Speed. Speeds higher than **Medium** should not use the AR. **Low** to **Medium** speeds benefit from AR, and typical values range from 1 mS to 100 mS.

**ACTUATOR SETUP MENU** - Enter ACTUATOR SETUP menu from Job Screen.

Sets the furthest extension of the tamp for the application with steps of one inch. Use this limit if the product distance to the labeler is consistent.

Sets the furthest extension of the tamp with ¼ inch steps.

Sets the overall speed of the Actuator to five discrete values, and depends on the application speed and throughput.

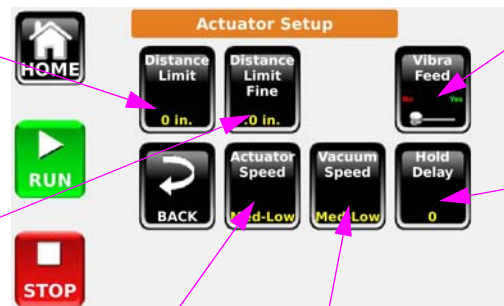

If enabled, the pad vibrates during label feed to help thicker labels or with stronger adhesive feed on the pad properly.

Sets how long the actuator should hold the same position.

**Note:** For most tamp applications, this value should be zero. For slow line speed applications, this value can be used to keep the pad in contact with the product longer, but with weaker (non-crushing) force. Holds the last position, versus continuing forward.

See chart below for recommended setting:

Profile	Label
Low	Label length > 203,2mm (8")
Med-Low	Label length > 203,2mm (8")
Medium	Label size closely matches pad size (i.e., 101,6mm x 152,4mm [4" x 6"] label on 101,6mm x 152,4mm [4" x 6"] pad)
Med-High	Label area is smaller than pad size by 50% (i.e., 101,6mm x 50,8mm [4" x 2"] label on 101,6mm x 101,6mm [4" x 4"] pad)
High	Label area is smaller than pad area by 70% (may require custom pad to accommodate)



### E-TAMP/BLOW Mechanical Setup

#### ALIGN TO PEEL BLADE

1. Loosen both screws on the dovetail slider (A).
2. Slide actuator assembly toward and away from peel blade until there is approximately 3,2mm (1/8") gap.
3. Tighten both screws (A).

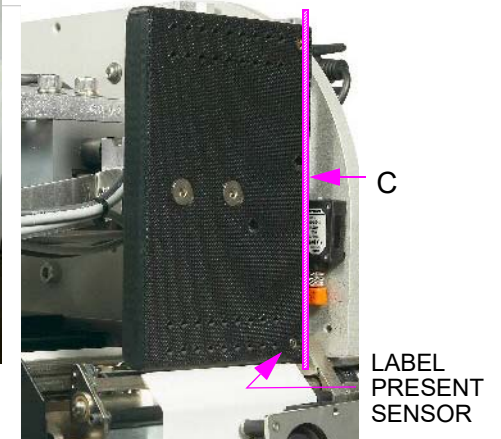
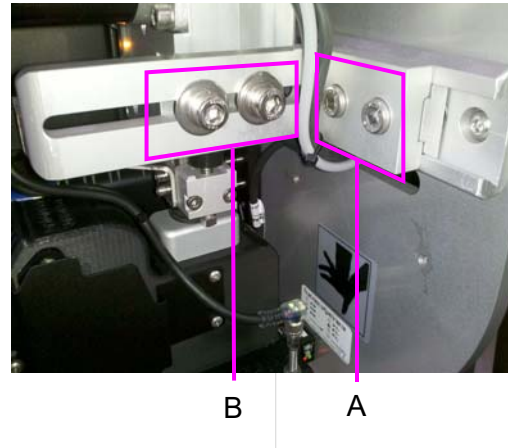

#### ALIGN LABEL WITH TAMP PAD

1. Loosen both screws on the tamp actuator L-bracket (B).
2. Slide the actuator assembly toward and away from the baseplate until the label present sensor will be covered by a fed label.
3. Tighten both screws on the tamp actuator L-bracket (B).

#### ALIGN TAMP PAD HEIGHT

1. Loosen the jam screw on the actuator rod.
2. Adjust the bumper height by turning the bumper so that the face of the peel blade is 1,6mm (1/16") **BEYOND** the peel blade.
3. Power on the Label Applicator to verify tamp pad home position.
4. Tighten the jam screw.

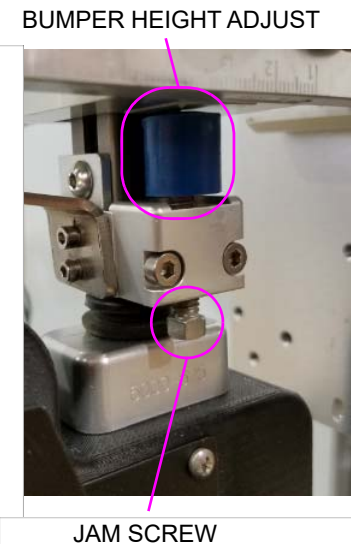
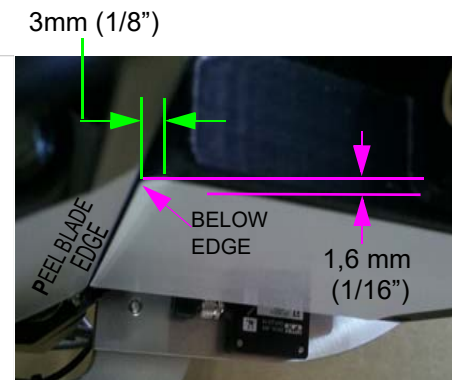

## E-TAMP/BLOW Parameter Setup

E-TAMP/BLOW applications allow the label to be placed on the Top or Side of a product. Typically, the label is transferred in a contact-less manner to the product. Alternatively, the tamp pad can make contact with the product and then blow (tamp-touch-blow) to help place a label into a recess or void area.

**LABEL MENU** - Enter LABEL Menu from the Home Screen.

Sets the amount of tension applied to the rewind on a print cycle. Set lower for print speeds less than 6 ips or labels shorter than 101,6mm (4”).

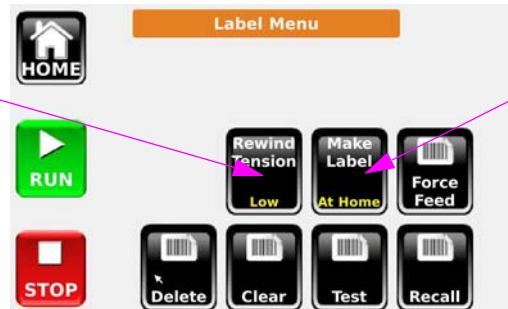

Determines the label generation mode. For slow applications, like pallets, make this **P1 Detect**. This will reduce the time the label adhesive is exposed to air and drying. For highest throughput, use **At Home**. Use **P2 Detect** for the highest accuracy (by using two detectors) when feed on demand is required. **Then Apply** prints a label when actuator is at Home position, then applies immediately.

**SYSTEM MENU** - Enter SYSTEM Menu from the Setup Screen.

Sets the rewind motor direction.

Set to the length of the actuator.

Sets the direction of the Actuator motor. This setting matches the A/B configuration of the actuator.



**E-Tamp** will be chosen for this application.

**Yes** will offset the label placement from the front. If the product lengths vary, and the label needs to be placed off of the trailing edge of the product, set to **No**.



### SMART MENU - Enter SMART Menu from the Setup Screen.

Determines if the system is being used with the optional Label Present sensor.

Determines how many times the label will be printed without an application. The available options are **1, 2, 3** and **Infinite**. To ensure a 1 Label to 1 Product match, set this to 1

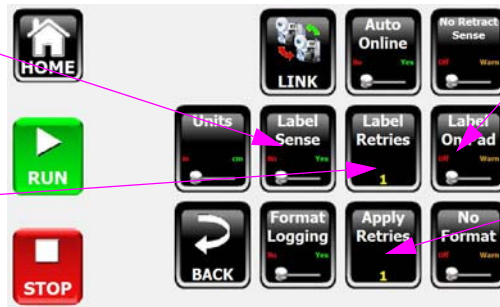

Provides a warning if the system is online with a prior label on the tamp pad. Helps avoid a potential label to product mismatch.

Determines how many times the system will attempt to apply the same label. The available options are **1, 2, 3** and **Infinite**. To ensure a 1 Label to 1 Product match, set this to 1.

### SETUP/JOB MENU - Enter JOB Menu from the Setup Screen.

**No** disables the Blow function (E-TAMP). **On Sensor** only activates the Blow function when the product is detected by Auto Retract Sensor. **On Retract** activates the Blow function when the actuator is returning due to Apply Duration expiring.

Keep as small as possible by locating the product sensor as close to the peel blade as possible. Exception - if print on demand is used.

Controls the extension stroke time. Set Auto-Retract to zero to properly adjust this time, then re-enable Auto Retract.

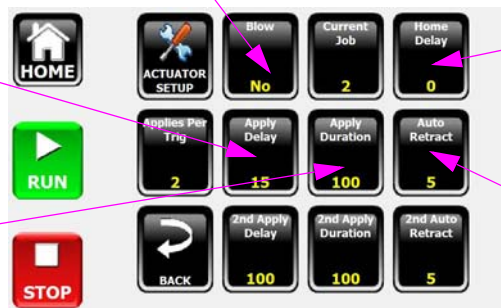

Most E-Tamp applications will not need much Home Delay. Large label sizes will benefit with a minimal delay of 20 mS to 100 mS.

If installed, the Auto-Retract (AR) time depends on the Actuator Speed. Typical values range from 1 mS to 100 mS.

**ACTUATOR SETUP MENU** - Enter ACTUATOR SETUP from the Job screen.

Sets the furthest extension of the tamp for the application with steps of one inch. Set distance just short of the product to blow label to the product.

Sets the furthest extension of the tamp with 6mm (1/4") steps.

Sets the overall speed of the Actuator to five discrete values.

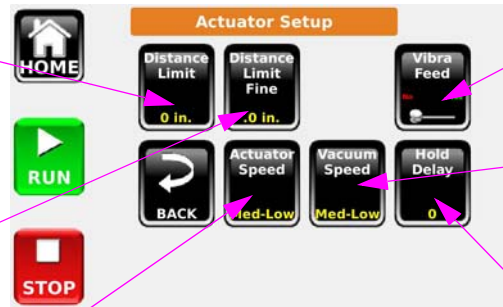

If enabled, the pad vibrates during label feed to help thicker labels or with stronger adhesive feed on the pad properly.

Vacuum Speed should be **Med\_High** or **High** for Tamp Blow.

Sets how long the actuator should hold the same position.

**Note:** Use this delay to keep the tamp pad at a fixed distance while the blow function is operating. A value between 50 mS and 100 mS makes the blow more effective.

## High Speed Tamp Mechanical Setup

### ALIGN TO PEEL BLADE

1. Loosen the two screws on the dovetail slider (A).
2. Slide assembly toward and away from the drive module until there is approximately 3,2mm (1/8") gap between the drive module peel blade and tamp pad edge.
3. Tighten the two screws (A).

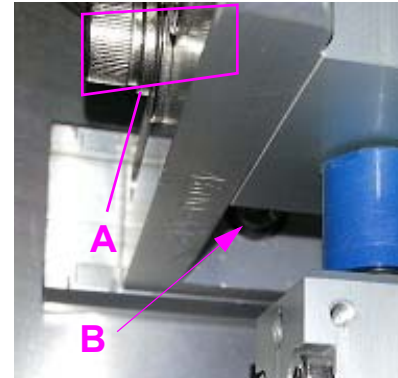

### ALIGN LABEL WITH TAMP PAD

1. Loosen the two screws on the L-bracket (B).
2. Slide the assembly toward and away from the baseplate until a fed label will cover the label present sensor.
3. Tighten the two screws on the L-bracket (B). Keep the actuator parallel to the baseplate during tightening.

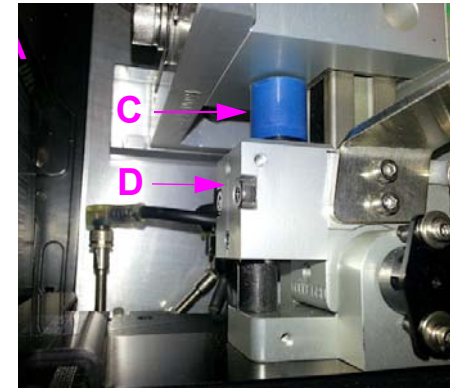

### ALIGN TAMP PAD HEIGHT

1. Loosen the set screw (D).
2. Adjust the bumper height (C) by turning the bumper so that the face of the peel blade is 1,6mm (1/16") **BEYOND** the peel blade.
3. Tighten the set screw (D).
4. Loosen the screws (E).
5. Slide the roller to set angle. The pad face should be parallel to the bottom edge of the baseplate.
6. Tighten the screws (E).

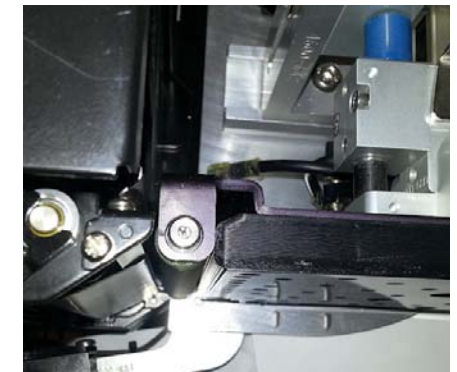

## High Speed Tamp Parameter Setup

High Speed Tamp (HST) applications allow the label to be placed on the Top or Side of a product. Typically, this application method allows for line speeds higher than a standard tamp module can handle. The actuator extends the pivoting plate down to the product and holds this position to allow the product to receive the label via the roller.

Alternatively, the HST can be used to follow the contour of the product. The same principles apply: the plate should not be setup to make flat contact with the product, but rather stop short, hold position, and let the pivoting-action of the tamp plate glide along the product's surface.

**LABEL MENU** - Enter LABEL Menu from the Home Screen.

Sets the amount of tension applied to the rewind on a print cycle. Set lower for print speeds less than 6 ips or labels shorter than 101,6mm (4").

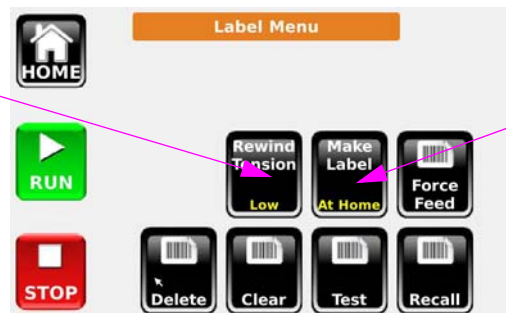

Determines the label generation mode. For slow applications, like pallets, make this **P1 Detect**. This will reduce the time the label adhesive is exposed to air and drying. For highest throughput, use **At Home**. Use **P2 Detect** for the highest accuracy (by using two detectors) when feed on demand is required. **Then Apply** prints a label when actuator is at Home position, then applies immediately.

**SYSTEM MENU** - Enter SYSTEM Menu from the Setup Screen.

Sets the rewind motor direction.

Set to the length of the actuator.

Sets the direction of the actuator motor. This setting matches the A/B configuration of the actuator.



**HS-Tamp** will be chosen for this application.

**Yes** will offset the label placement from the front. If the product lengths vary, and the label needs to be placed off of the trailing edge of the product, set to **No**.

### SMART MENU - Enter SMART Menu from the Setup Screen.

Determines if the system is being used with the optional Label Present sensor.

Determines how many times the label will be printed without an application. The available options are **1**, **2**, **3** and **Infinite**. To ensure a 1 Label to 1 Product match, set this to 1



Provides a warning if the system is online with a prior label on the tamp pad. Helps avoid a potential label to product mismatch.

Determines how many times the system will attempt to apply the same label. The available options are **1**, **2**, **3** and **Infinite**. To ensure a 1 Label to 1 Product match, set this to 1.

### SETUP/JOB MENU - Enter JOB Menu from the Setup Screen.

Keep as small as possible by locating the product sensor as close to the peel blade as possible. Exception - if print on demand is used.

Controls the extension stroke time. Set Auto-Retract to zero to properly adjust this time, then re-enable Auto Retract.



Most E-Tamp applications will not need much Home Delay. Large label sizes will benefit with a minimal delay of 20 mS to 100 mS.

**Note:** Auto Retract is not used with High Speed Tamp.

**ACTUATOR SETUP MENU** - Enter ACTUATOR SETUP menu from the Job screen.

If enabled, the pad vibrates during label feed to help thicker labels or with stronger adhesive feed on the pad properly.

Sets the furthest extension of the tamp for the application with steps of one inch. Use this limit if the product distance to the labeler is consistent.

Sets the furthest extension of the tamp with 6mm (1/4") steps.

Sets the overall speed of the Actuator to five discrete values.

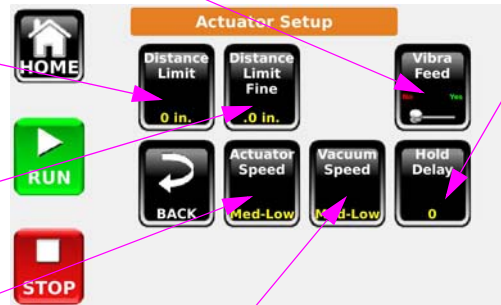

Sets how long the actuator should hold the same position.

**Note:** For CONTOURING APPLICATIONS use the Distance Limit to set the fixed position to pivot from and increase the Hold Delay to apply all of the label. May need to increase Apply Duration to keep actuator in position for the whole Hold period.

**Note:** For HIGH-SPEED APPLICATIONS minimize stroke length and hold time. Keep the tamp plate engaged to the roller bumper, and extend just long enough to pivot. Lower Actuator Speeds are better for this action.

See chart below for recommended setting:

Profile	Label
<b>Low</b>	Label length > 203,2mm (8")
<b>Med-Low</b>	Label length > 203,2mm (8")
<b>Medium</b>	Label size closely matches pad size (i.e., 101,6mm x 152,4mm [4" x 6"] label on 101,6mm x 152,4mm [4" x 6"] pad)
<b>Med-High</b>	Label area is smaller than pad size by 50% (i.e., 101,6mm x 50,8mm [4" x 2"] label on 101,6mm x 101,6mm [4" x 4"] pad)
<b>High</b>	Custom pads of smaller label sizes



### E-FASA Mechanical Setup

#### PEEL BLADE GAP ADJUSTMENT

1. Loosen the four screws on the dovetail slider (A).
2. Slide assembly toward and away from the peel blade until there is approximately 3,2mm (1/8") gap between the peel blade and tamp pad edge.
3. Tighten the four screws (A).

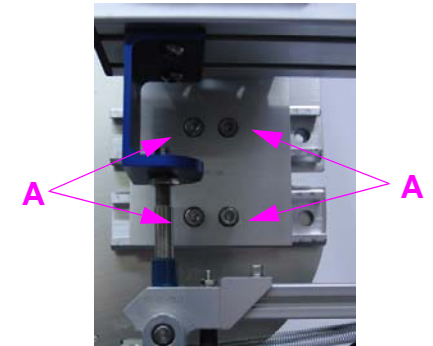

#### BASEPLATE ADJUSTMENT

1. Loosen the four screws on the L-bracket (B).
2. Slide E-FASA assembly toward and away from the baseplate until a fed label will cover the label present sensor.
3. Tighten the four screws on the L-bracket (B).

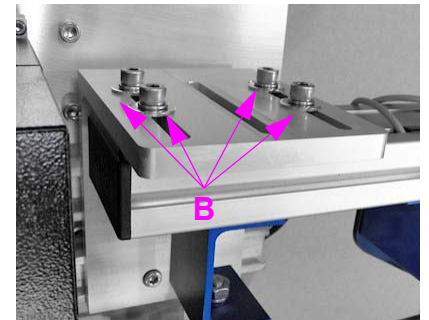

#### HEIGHT POSITION ADJUSTMENT

1. Loosen the jam nut (C).
2. Set height by rotating bumper rod (D).
3. Adjust the tamp pad height to 1,6mm (1/16") **BEYOND** the peel blade.
4. Check home position by powering up the system.
5. Tighten the jam nut (C).

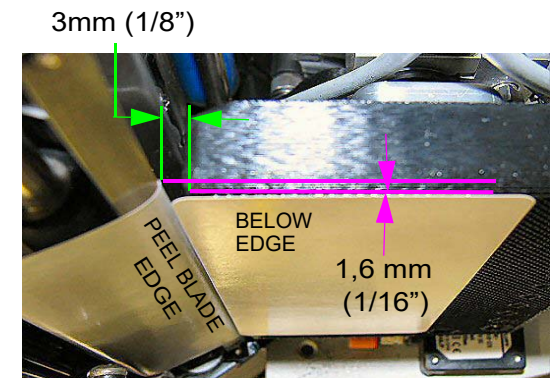
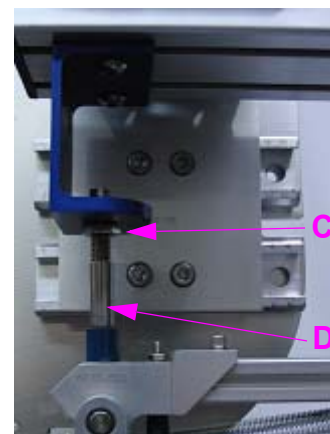

### PAD ANGLE ADJUSTMENT

1. Loosen the jam nut (E).
2. Tighten or loosen the bumper (F) to rotate the pad, making it parallel with the baseplate.
3. Tighten the jam nut (E).

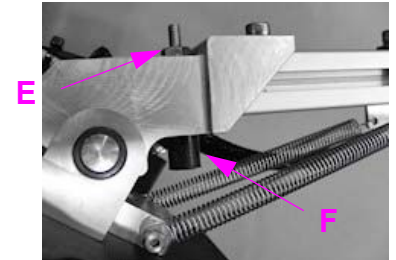

### PIVOT SPRING TENSION ADJUSTMENT

1. Loosen bolt (G).
2. Slide the bracket closer or further from the rod end to loosen or tighten the spring.
3. Tighten bolt (G).
4. Test label application. Pad should not “slap” the product when labeling.

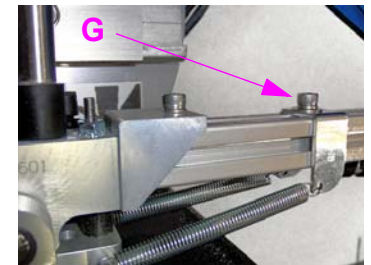

### HOME SENSOR ADJUSTMENT

1. Turn adjustment screw to loosen enough to slide the sensor (H).
2. With arm in home position, slide home sensor toward machine and then slowly slide it away from the machine until the light turns on.
3. Tighten adjustment screw. Do not over-tighten.
4. Verify that the home sensor light turns off when the pad is moved about 25,4mm (1”) away from the home bumper.

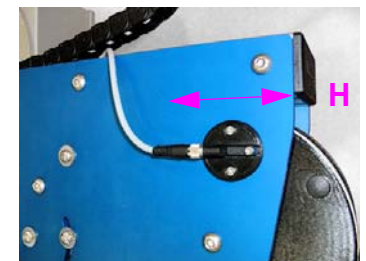



## E-FASA Parameter Setup

The E-FASA application module allows for either one or two product panel applications. In single label applications, either the front or rear panels can be labeled. In dual label applications, either the front and side, front and top, side and rear, or top and rear panels can be labeled.

**LABEL MENU** - Enter LABEL Menu from the Home Screen.

Sets the amount of tension applied to the rewind on a print cycle. Set lower for print speeds less than 6 ips or labels shorter than 101,6mm (4").

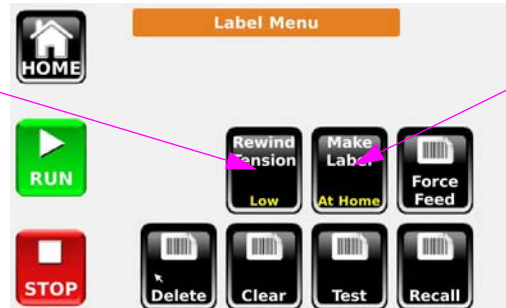

Determines the label generation mode. For slow applications, like pallets, make this **P1 Detect**. This will reduce the time the label adhesive is exposed to air and drying. For highest throughput, use **At Home**. Use **P2 Detect** for the highest accuracy (by using two detectors) when feed on demand is required. **Then Apply** prints a label when actuator is at Home position, then applies immediately.

**SYSTEM MENU** - Enter SYSTEM Menu from the Setup Screen.

Set to the length of the actuator.

**Note:** This is an important setting, since it regulates the overall speed of the arm. Faster speeds are allowable for the 12cm (5") arm and reduced for the 25cm (10") and 50cm (20"). Proper function of the system requires the correct match of the Actuator Length and the physical length of the E-FASA arm. The length of the E-FASA is the usable length of the arm, measured between the baseplate edge and the tamp pad center. For 19cm (7.5"), set to 25cm (10"); for 38cm (15"), set to 50cm (20").

Sets the rewind motor direction.

Sets the direction of the Actuator motor. This setting matches the A/B configuration of the actuator and is different with different applications



**E-FASA** will be chosen for this application.

**Yes** will offset the label placement from the front. If the product lengths vary, and the label needs to be placed off of the trailing edge of the product, set to **No**.

### SMART MENU - Enter SMART Menu from the Setup Screen.

Determines if the system is being used with the optional Label Present sensor.

Determines how many times the label will be printed without an application. The available options are **1, 2, 3** and **Infinite**. To ensure a 1 Label to 1 Product match, set this to 1.



Provides a warning if the system is online with a prior label on the tamp pad. Helps avoid a potential label to product mismatch.

Determines how many times the system will attempt to apply the same label. The available options are **1, 2, 3** and **Infinite**. To ensure a 1 Label to 1 Product match, set this to 1.

### SETUP/JOB MENU - Enter JOB Menu from the Setup Screen.

If the application requires two labels, front and side panels, this delay can be kept minimal. If the application is side and rear panels, the product sensor will have to be relocated, and delay will therefore need to increase.

Should be greater than the time required to print two labels (if using Make Label PD Sensor 1 or 2) or print one label (Make Label = At Home mode) plus the first apply cycle.

Should be incrementally set from low values to higher values to adjust the contact point with the product. For the front or rear panels, the optimum contact point is a little beyond 90 degrees. This allows the pad to pivot, and place the label squarely on the product.

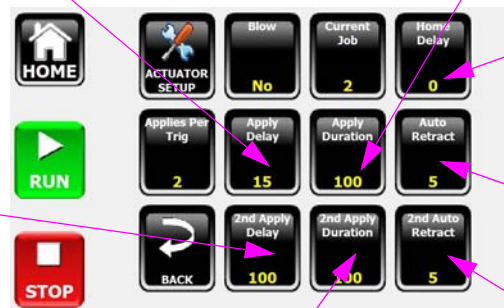

Most E-FASA applications benefit from some minimal delay between 50 mS to 200 mS, to allow the pad to settle when arriving home.

Not very useful for the front and rear panels, but mainly used for the side application. Values between 1 mS and 50 mS are typical.

Values between 1 mS and 50 mS are typical.

Same as Apply Duration.

## ACTUATOR SETUP MENU - Enter ACTUATOR SETUP menu from the Job screen

Sets the furthest swing angle for this application.

**Note:** Use this limit for the front or rear panel swing (typically 90 degrees). Can be used in conjunction with the Hold Delay to swing out and wait for the product's front panel. If Hold Delay is long enough, will perform a corner wrap on product.

Sets the overall speed of the Actuator to five discrete values.

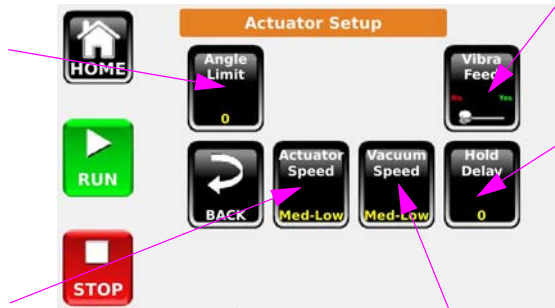

If enabled, the pad vibrates during label print/feed to help thicker labels or with stronger adhesive feed on the pad properly.

Sets how long the actuator should hold the same position.

See the chart below for recommended setting:

Profile	Label
<b>Low</b>	Label length > 203,2mm (8")
<b>Med-Low</b>	Label length > 203,2mm (8")
<b>Medium</b>	Label size closely matches pad size (i.e., 101,6mm x 152,4mm [4" x 6"] label on 101,6mm x 152,4mm [4" x 6"] pad)
<b>Med-High</b>	Label area is smaller than pad size by 50% (i.e., 101,6mm x 50,8mm [4" x 2"] label on 101,6mm x 101,6mm [4" x 4"] pad)
<b>High</b>	Custom pads of smaller label sizes

### E-WASA Mechanical Setup

#### ADJUST “X” POSITION

1. Loosen the two screws on the slider track (A).
2. Slide the WASA module until there is approximately 3,2mm (1/8”) between the peel blade and the edge of the Fan Box.
3. Tighten the screws (A).

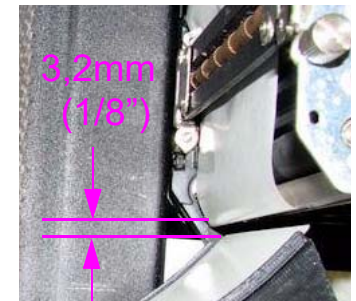
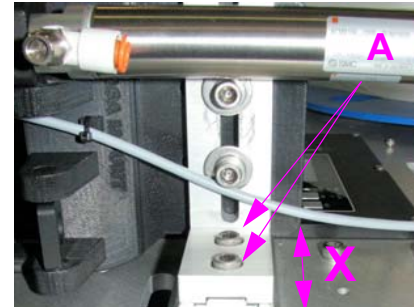

#### ADJUST “Y” POSITION

1. Loosen the two screws (B).
2. Feed a label out to the fan box.
3. Label should dispense within 3,2mm (1/8”) of raised edge, but **NOT** on the raised edge.

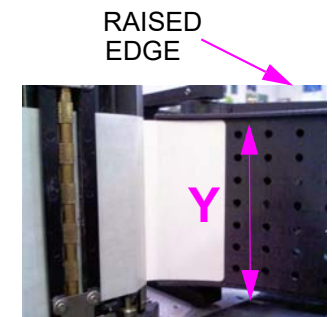
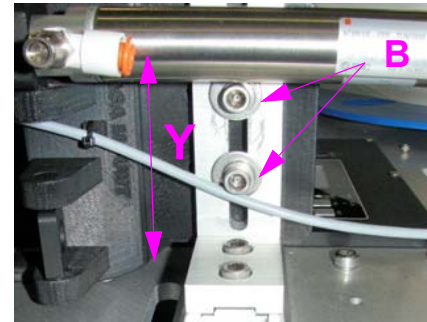

#### ADJUST ROTATION ANGLE “Z” POSITION

1. Loosen two nuts (C) on the cylinder.
2. Turn the cylinder body to thread the rod in or out of the coupling to adjust the “Z” rotational position of the Fan Box.
3. Adjust the rotation so that the label feeds out to the Fan Box without stalling on the surface of the face.
4. Tighten both nuts (C) and feed a few labels to determine if the position is ideal.

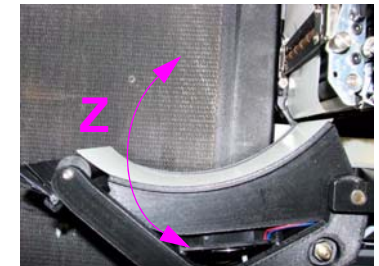
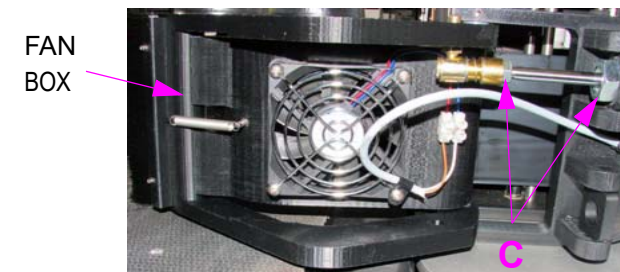



### ADJUST SPRING RATE

1. Loosen the jam nut with a 13mm open-end wrench.
2. Turn the Screw Adjustment clockwise to increase the spring force, and counterclockwise to reduce it. Products that are under 2,3~4,5 kg (5~10 lbs) require less spring force to allow the label to be wrapped without making the product stall on the conveyor. Too light of a spring tension will result in a poorly wrapped label. The full range of spring tension is accomplished within a 50,8mm (2") screw threading distance.



**WARNING:** Do not decrease the spring tension so far that the WASA Fan Box does not consistently return home. If the spring is too weak, friction and product placement will begin to effect the performance of the label wrap.



**NOTE:** The E-WASA is highly dependent on a rear guide rail for optimal performance. Since the E-WASA is spring-loaded to apply pressure to the front and side of the product, the guide rail prevents possible product skew. Operation without the proper material handling will result in poor wrap angle or label wrinkle.

3. When the WASA travel has been checked for the swing range of motion, lock in the spring tension position by tightening the jam nut.

### ADJUST RETURN FLOW CONTROL

Loosen the thumb wheel jam nub and turn the flow control clockwise to reduce the speed that the WASA returns to the home position. Increase the flow by turning the control counterclockwise, which will allow the WASA box to return home faster.



**WARNING:** The adjustment on the return speed will determine the maximum throughput rate. If the application can tolerate a slower return rate, it will result in a smoother and gentler return, which will result in longer life.



**NOTE:** The E-WASA is highly dependent on a rear guide rail for optimal performance. Since the E-WASA is spring-loaded to apply pressure to the front and side of the product, the guide rail prevents possible product skew. Operation without the proper material handling will result in poor wrap angle or label wrinkle.

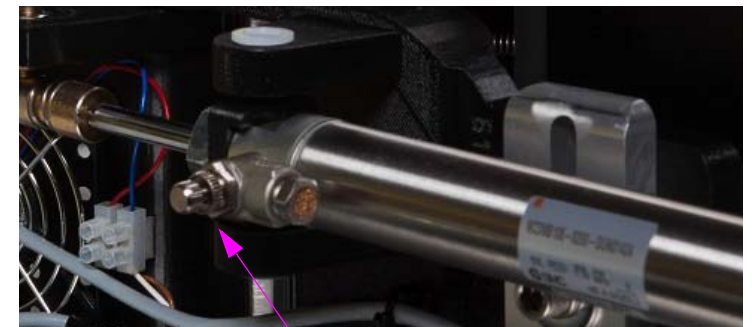
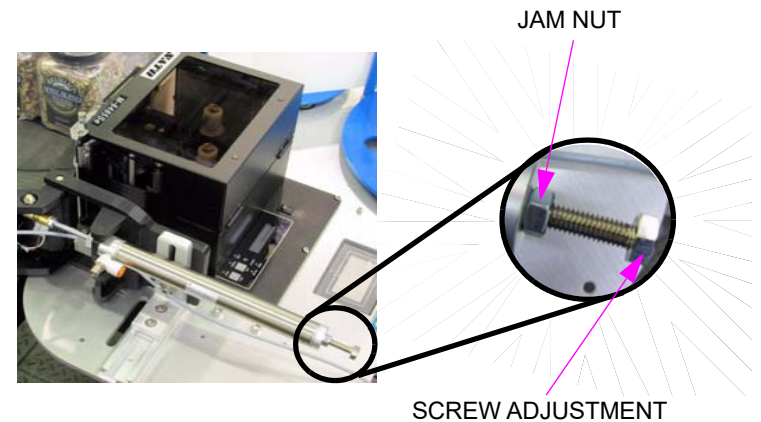

FLOW CONTROL SET SCREW

### E-WASA Parameter Setup

E-WASA applications allow the label to be placed on two adjacent panels, typically front and side, but front and top is also possible. Since the E-WASA cannot accept the next label until the arm returns home, it is a label print on demand by default.

**LABEL MENU** - Enter LABEL Menu from the Home Screen.

Sets the amount of tension applied to the rewind on a print cycle. Set lower for print speeds less than 6 ips.

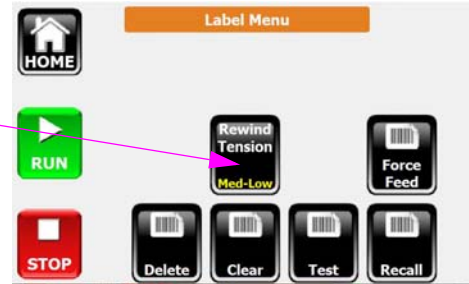

**SYSTEM MENU** - Enter SYSTEM Menu from the Setup Screen.

Sets the rewind motor direction.



**E-WASA**, if there is no Home Sensor and **E-WASA+**, if there is a Home Sensor.

**SETUP/JOB MENU** - Enter JOB Menu from the Setup Screen.

Determines the amount of time to delay from the product detector trigger to the label printing. Usually kept at a minimum value.

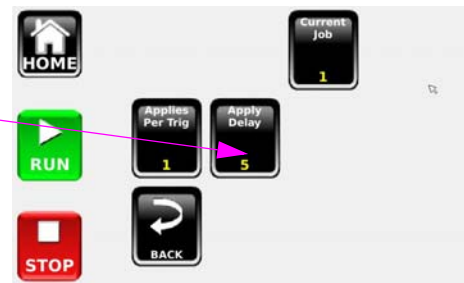

## Appendix C: Electrical Interface

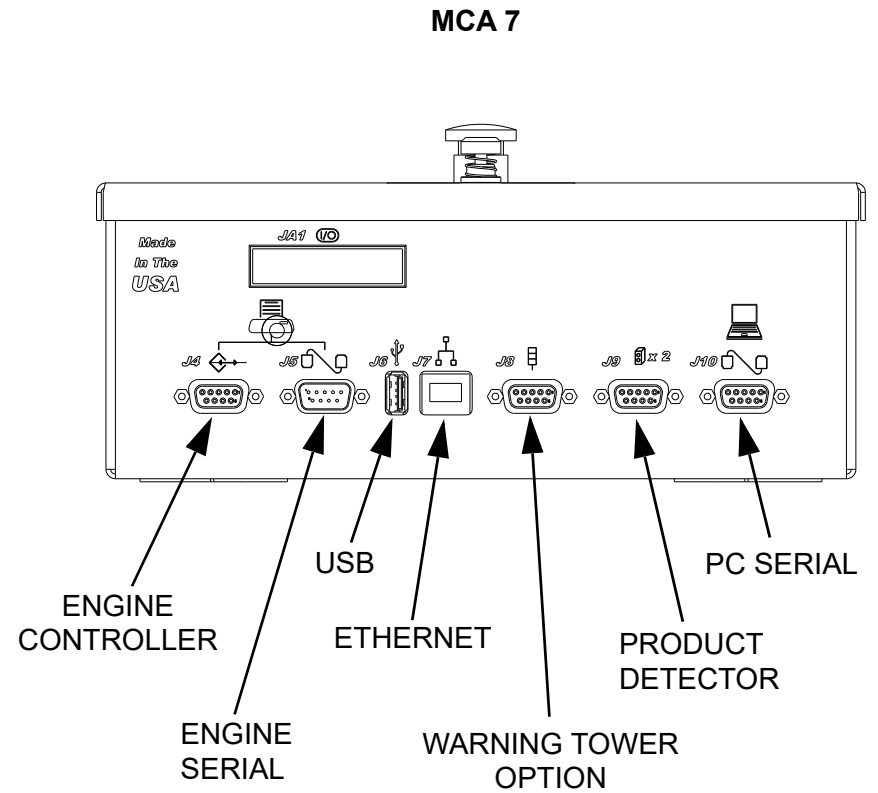
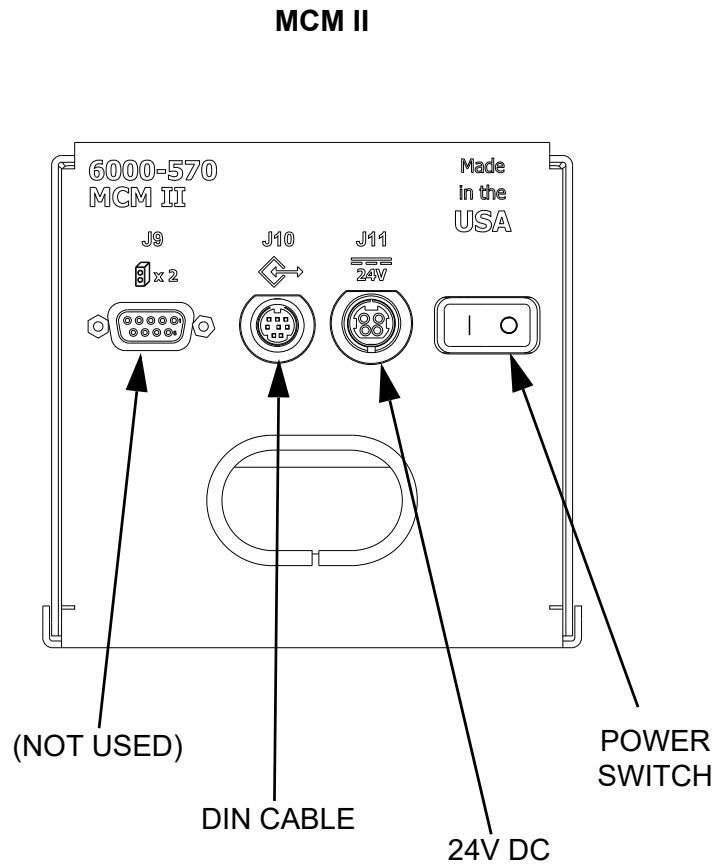

## Appendix D: Language Support

The following languages are supported by the 7100 Series Printer Applicator.

**NOTE:** Print message support is through Nice Label software.

User Interface (via Regional Settings)	Print Messages (via Message Editor)
<i>(not available)</i>	中文 (Chinese)
Deutsch (German)	Deutsch (German)
English	English
Español (Spanish)	Español (Spanish)
Français (French)	Français (French)
<i>(not available)</i>	Italiano (Italian)
<i>(not available)</i>	日本人 (Japanese)
<i>(not available)</i>	한국어 (Korean)
<i>(not available)</i>	Polski (Polish)
Português (Portuguese)	<i>(not available)</i>
<i>(not available)</i>	Русский (Russian)
<i>(not available)</i>	Slovenski (Slovakian)



## Appendix E: Part Numbers

### Service Parts

#### System Components

Item	Kit No.	Description
1	4600-900	Product Detector Assembly, Diffuse
2	1901-141	AC Power Cable
3	4600-647	Rewind Clasp
4	4600-950	Standard Wear Items Kit - Includes: (3) 4600-607 Label Core Fins, (1) 4600-643 Urethane Spindle, (1) 4600-649 Kevlar Belt, (1) 5331-221 Spring, 38mm (1.5"), (1) 5331-222 Spring, 63mm (2.5"), (2) 6105-066 Web Guide Spring Collars, (3) 6150-600 Spring Anchors, (6) 5750-039 Mounting Screws, (1) 4600-612 Rewind Tensioner Assembly, (1) 404508 Stainless Steel Guide Rod
5	6000-840	Container of Fasteners, 7000 Series
6	404223	Motor Assembly (not shown)
7	404224	Guide Rod Kit - Includes: (1) Stainless Steel Guide Rod, M8 Thread, (1) Stainless Steel Guide Rod, M14 Thread

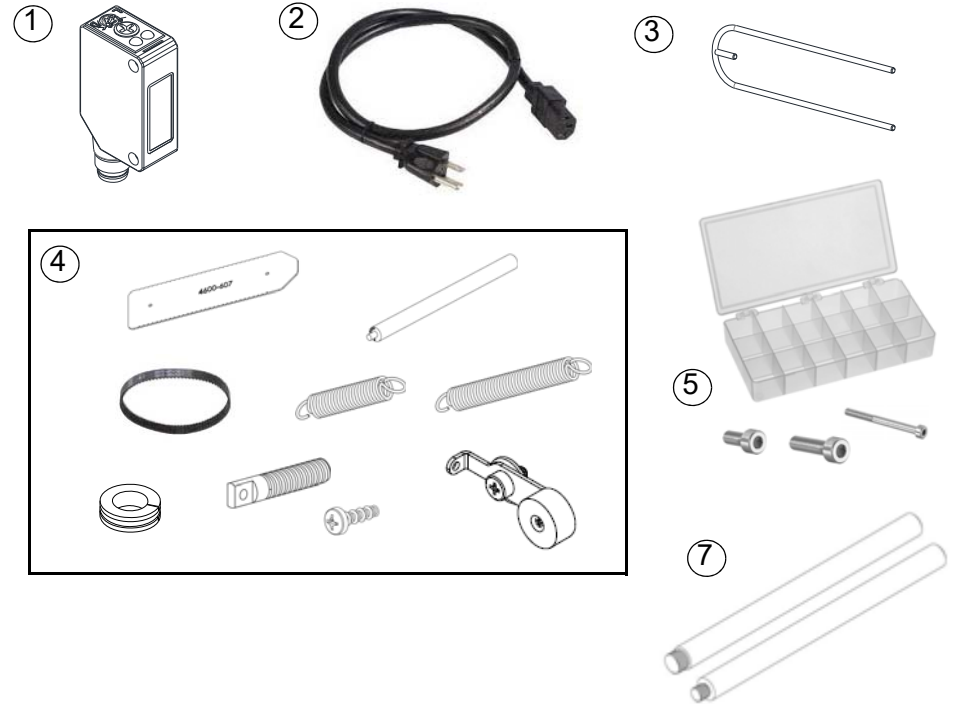

**NOTE:** For service parts related to Print Engines, refer to document 6000-013.

#### MCA Components

Item	Kit No.	Description
1	404202	PC Board Assembly & Display Board
2	404200-LS7100	Display Assembly, 18cm (7")
3	404201	MCA Assembly - Includes MCA 7 Enclosure, MCA 7 PCB & Display Board

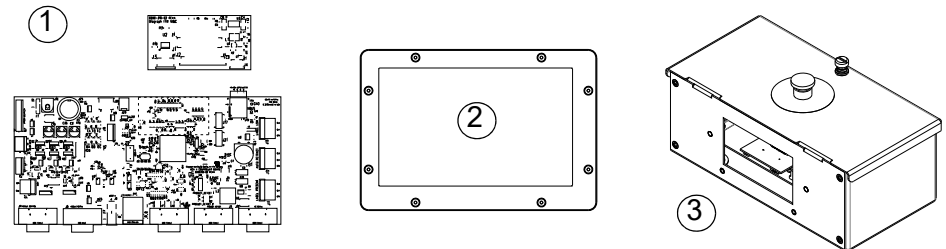

## Applicator Components

Item	Kit No.	Description
1	6000-205X5	Actuator Extrusion, 127mm (5") Tamp
	6000-205X10	Actuator Extrusion, 254mm (10") Tamp
	6000-205X15	Actuator Extrusion, 381mm (15") Tamp
	6000-205X20	Actuator Extrusion, 508mm (20") Tamp
	6000-205X25	Actuator Extrusion, 635mm (25") Tamp
	6000-205X30	Actuator Extrusion, 762mm (30") Tamp
2	6000-698KIT	MCM II Board Replacement
3	4600-906	Home Sensor
4	6000-214	Vacuum Fan Replacement
5	6000-211	MCM II Assembly - Includes: (1) MCM II Circuit Board (1) MCM II Enclosure
6	6000-207	Air Assist Fan and Filter (bracket not included)
7	6000-219	Air Assist Mounting Bracket and Filter (fan not included)
8	6000-201-B	Tamp Pad Mount, Blue
	6000-201-G	Tamp Pad Mount, Green
	6000-201-R	Tamp Pad Mount, Red
9	6000-950 For Applicator:	E-TAMP Wear Items - Includes: (8) 6000-624 Bearing Pads, (1) 6150-601 Bumper, (6) 6150-580 Cable Ties, (1) 6000-629 Clamp Plate, (1) 6000-638 Roller, (2) 5030-712 M5 Screws, (2) 6000-795 Spring Compressor Tools, (2) 5331-002 Wave Springs, (1) 6000-794 Timing Belt Threading Tool, (1) 6000-633 Timing Belt, (1) 6000-627 Top Plate & (2) 6000-635 Maytec Connectors
10	6000-951 For Applicator:	E-FASA Wear Items - Includes: (1) 6000-713 Black Motor Drive Belt, (1) 6000-712 White Swing Arm Belt, (1) 6170-480 Bumper, (1) 6150-601 Male Bumper, (6) 6150-580 Cable Ties, (1) 5030-508 8-32 Screw, (2) 5331-220 Springs & (1) 6000-821 19mm (3/4") Sq. Tape
(Continued on next page...)		

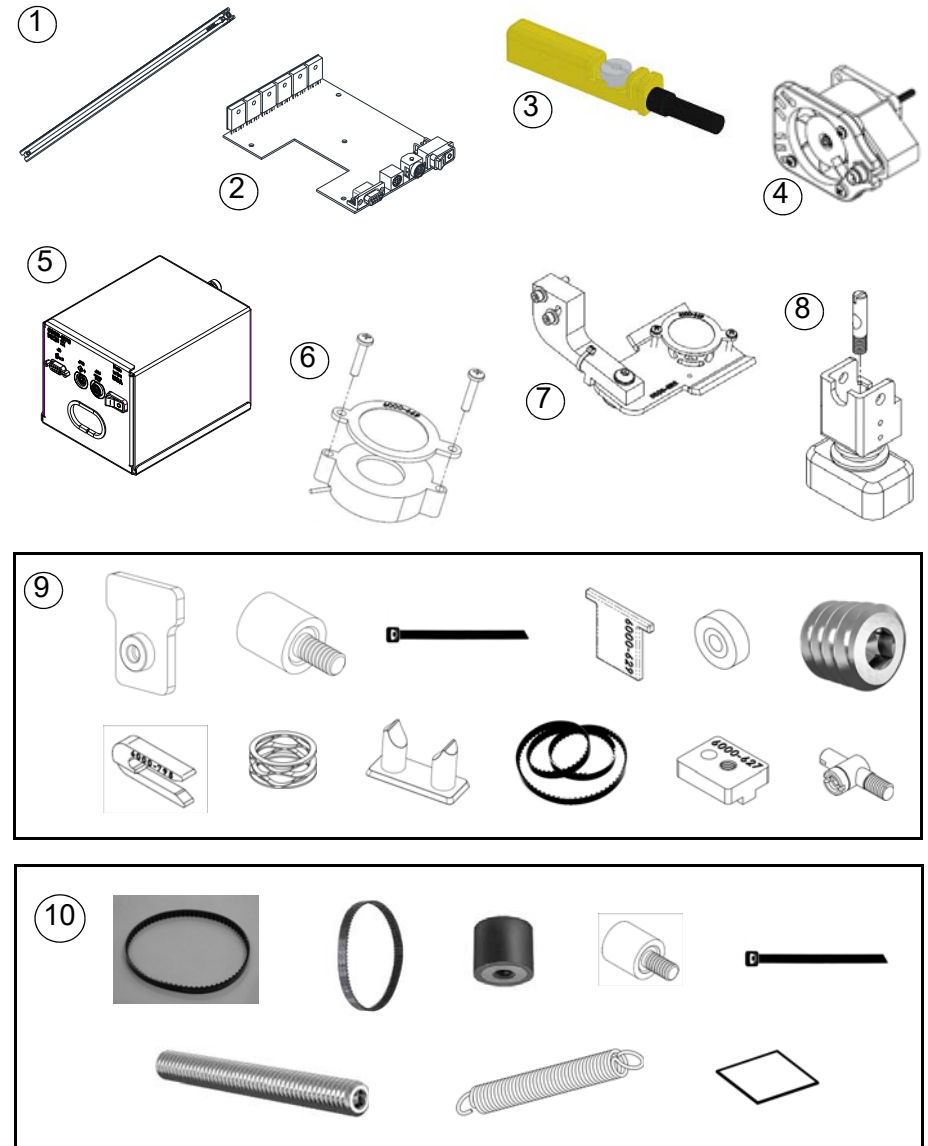

## Applicator Components (Continued)

Item	Kit No.	Description
11	6000-952 For Applicator	E-WASA Wear Items - Includes (1) each: 5331-220 Spring, 6170-583 Roller, 6170-509 Fan 6146-653 12cm (5") Brush & 6170-582 18cm (7") Brush

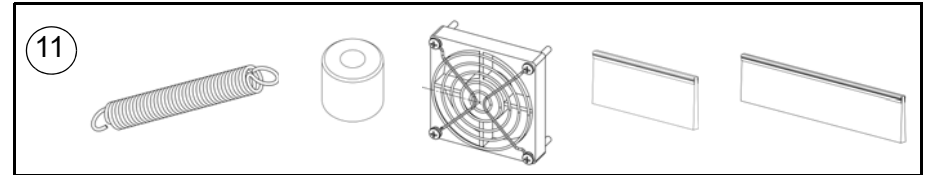
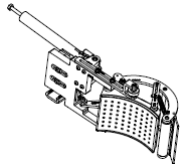

## Optional Equipment

Item	Kit No.	Description
1	4600-901	Product Detector, Break-Beam
	4600-902	Product Detector, Laser
2	6000-518	Y-Cable, Product Detector
3	5780017FXALP	Remote Hand-Held
4	404221	Parking Brake
5	6000-903	Auto Retract or Label Present Sensor
6	404226	Low Label Sensor with Bracket
7	4750-216	Core Adapter, 76,2mm to 152,4mm (3" to 6")
8	6000-828	Warning Tower, 3-Color
9	6000-828AUD	Warning Tower, 3-Color with Audible Alarm
10	9650-830L	Large Air Assist, Left Hand
	9650-830R	Large Air Assist, Right Hand
11	4600-625	Tie-Down Cleats, Standard CHI Stand (3 Pack)
	401208	Tie-Down Cleats, RLC Heavy Duty Stand (3 Pack)
12	5765-244	Levelers (4 Pack)

