

Operations Manual

7000 Series Label Applicator

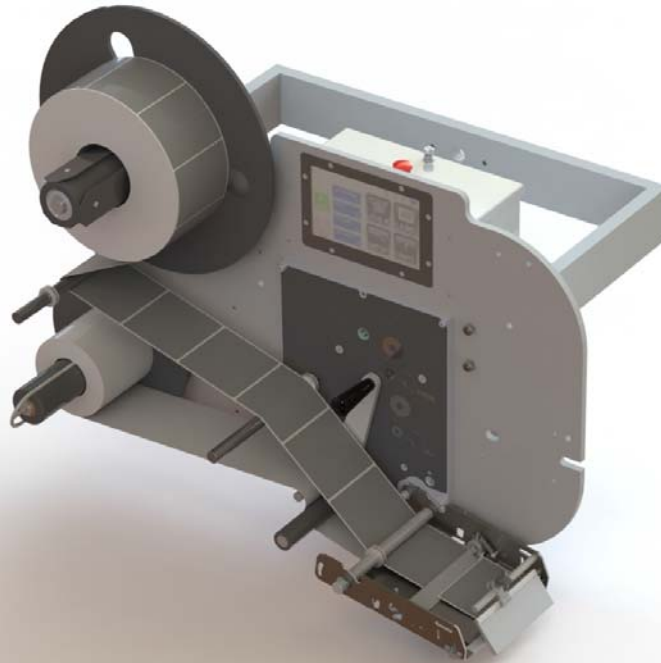

404011FX
Revision C

7000 Series Label Applicator Operations Manual

**404011FX
Revision C**

The information contained in this manual is correct and accurate at the time of its publication. The manufacturer reserves the right to change or alter any information or technical specifications at any time and without notice.

©2021 Illinois Tool Works Inc.
All rights reserved

7000 Series Label Applicator

Warranty:

The 7000 Series Label Applicator, including all components unless otherwise specified, carries a limited warranty.

For all warranty terms and conditions, contact the manufacturer for a complete copy of the Limited Warranty Statement.

7000 Series Label Applicator

Section 1: Safety	1
Section 2: Quick Start	3
Step 1: System Orientation	4
Step 2: System Alignment	6
Step 3: Position Product Detector	7
Step 4: Position Nip Roller	8
Step 5: Load Media	9
Step 6: Calibrate Gap Sensor	12
Step 7: Set Speed	13
Step 8: Set Dispense Position	13
Step 9: Set Rewind Tension	14
Step 10: Set Product Delay	14
Step 11: Set Apply Duration (Tamp Applicator only)	15
Step 12: Set Actuator Distance Limit (Tamp Applicator only)	15
Step 13: Set the System Online	16
Section 3: Maintenance	17
Maintenance Schedule Chart	17
Section 4: Troubleshooting	18
Common to All Systems	19
Wipe Systems	20
Tamp Systems	21
Diagnostics	22
Information, Warning, Error, and Diagnostic Codes	23
Appendix A: System Specifications	24
General Specifications	24
Electrical Specifications	25
Performance Specifications	25
Wipe 152,4mm (6")	27
E-TAMP & E-TAMP/BLOW	28

7000 Series Label Applicator

E-FASA 10 in.	29
E-WASA	30
Standard T-Base Stand (CHI, 54" Upright)	31
Floor Mount Stand (54" Upright)	32
Heavy Duty T-Base Stand (54" Upright)	33
Heavy Duty U-Base Stand (54" Upright)	34
Appendix B: Application Methods	35
E-TAMP Mechanical Setup	35
E-TAMP Parameter Setup	36
E-TAMP/BLOW Mechanical Setup	39
E-TAMP/BLOW Parameter Setup	40
High Speed Tamp Mechanical Setup	43
High Speed Tamp Parameter Setup	44
E-FASA Mechanical Setup	47
E-FASA Parameter Setup	49
E-WASA Mechanical Setup	52
E-WASA Parameter Setup	54
WIPE Mechanical Setup	55
WIPE Parameter Setup	56
WIPE - Line Encoder Enabled - Mechanical Setup	58
WIPE - Line Encoder Enabled - Parameter Setup	59
Appendix C: Electrical Interface	61
Appendix D: Language Support	62
Appendix E: Part Numbers	63
Replacement Kits	63
Service Parts	65
Optional Equipment	67

Section 1: Safety

Safety awareness is critical when working with equipment that contains moving parts and extending electric actuators. Please read all warnings and cautions thoroughly before operating this device.

Following is a list of safety symbols and their meanings, which are found throughout this manual. Pay attention to these symbols where they appear in the manual.



Wear safety goggles when performing the procedure described!



Caution or Warning! Denotes possible personal injury and/or damage to the equipment.



Caution or Warning! Denotes possible personal injury and/or equipment damage due to electrical hazard.



NOTE: (Will be followed by a brief comment or explanation.)



ESD protection should be worn when servicing internal printed circuit boards.
After service to the equipment is completed, replace all protective devices such as grounding cables and covers before operating the equipment.



Caution or Warning! Denotes possible personal injury due to heat.



Caution or Warning! Denotes possible personal injury due to pinching/crushing.



Caution or Warning! Denotes possible personal injury due to pinching/crushing.

WARNING! Tipping hazard: Tie-down cleats are required to be secured to the ground when using this product on non-flat or uneven surfaces and/or where the center of mass may cause an unsafe condition. (See “Optional Equipment” on page 67 for part numbers.)

WARNINGS

- WARNING - Moving parts of this machine can present hazards. Components that cannot be guarded because of loss of functionality are marked with a warning symbol.
- Be aware of the actuator extension distance, and avoid accidental triggering of the photosensor.
- When servicing the unit's electronic assemblies, always remove the power cord from the unit to prevent accidental shock.
- When running for extended periods of time, use caution when accessing the drive module circuitry. The motor drive power transistors, motor case, and motor heatsink can become hot under constant use.
- Wear personal protective equipment, as instructed by your supervisor, when operating or working near this device.
- A connection to a grounded power outlet is required. The power outlet should remain accessible after installation for emergency power disconnect.

Section 2: Quick Start

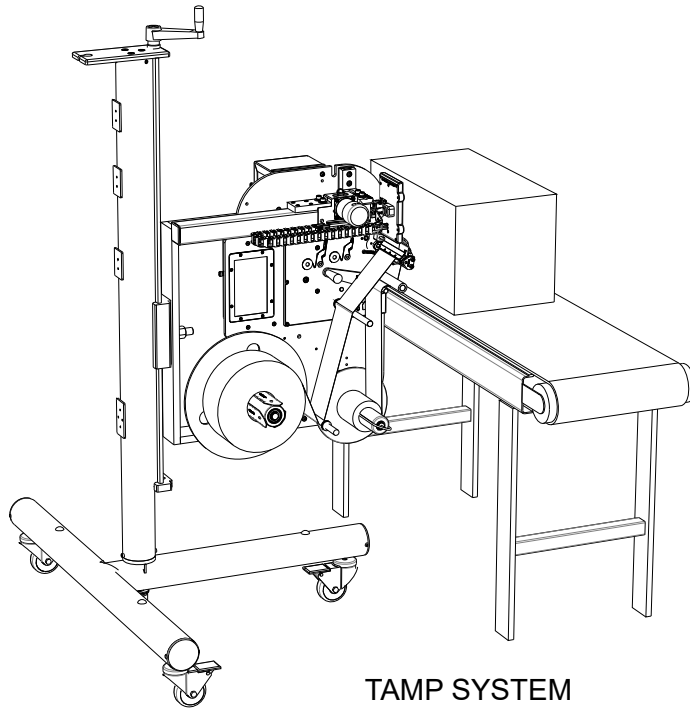

TAMP SYSTEM

Contents:

- * Main Applicator
- * Product Detector Kit
- * Power Cord
- * Manual (Digital Copy)

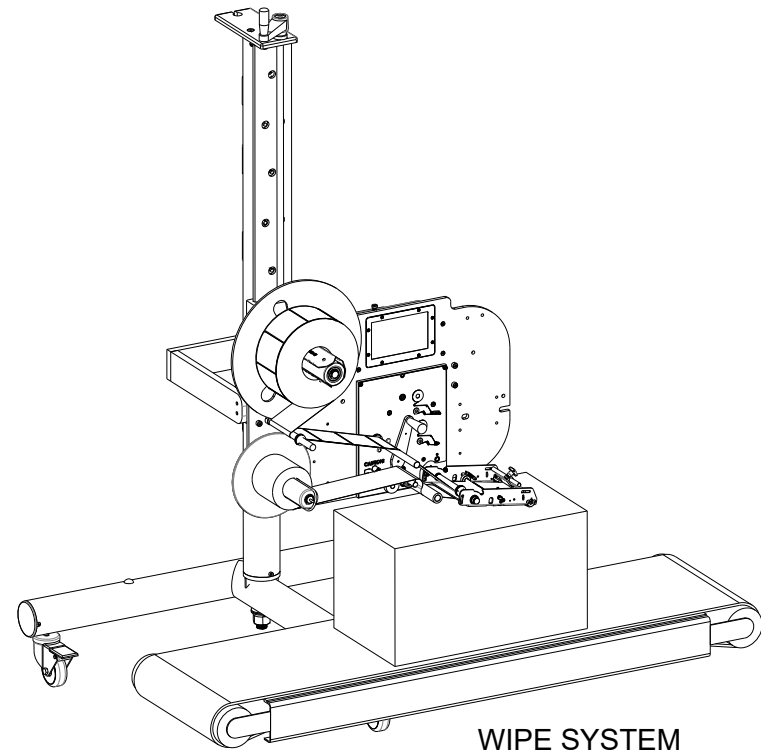

WIPE SYSTEM

Step 1: System Orientation

Caution: System is top heavy; take care when adjusting roll. Tie-Down Cleats are recommended to secure Stand and Applicator into place while in use (see “Optional Equipment” on page 67).

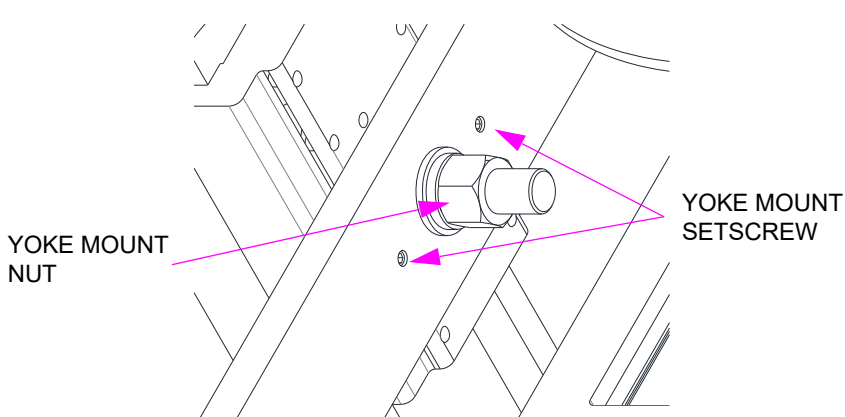

Pitch Adjustment

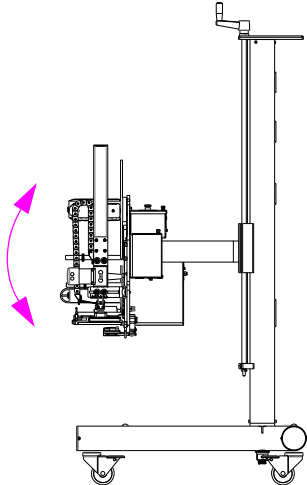
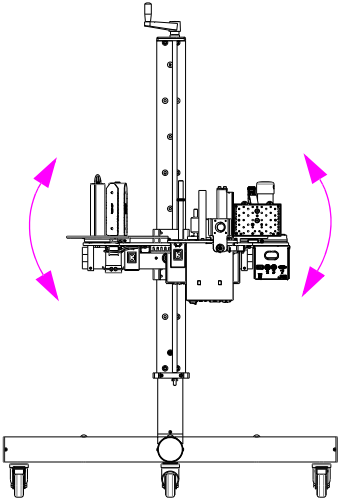

Roll Adjustment

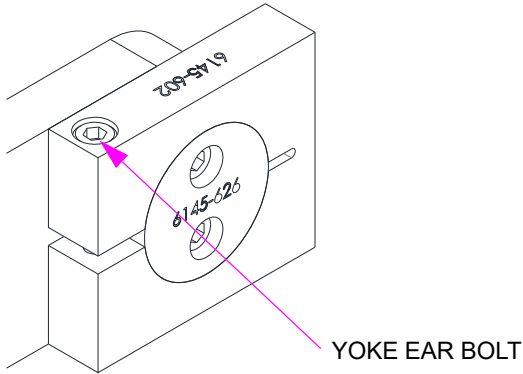

ORIENTATIONS

Using the Yoke Mount Nut, Yoke Ear Bolts and Yoke Mount Setscrews, adjust the Label Applicator to the desired orientation.

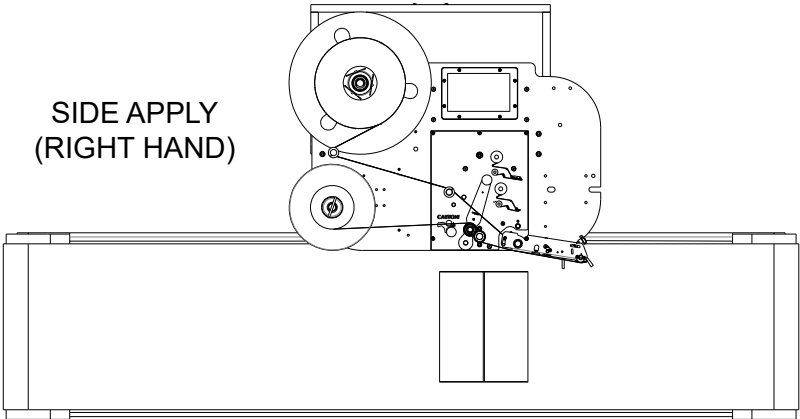
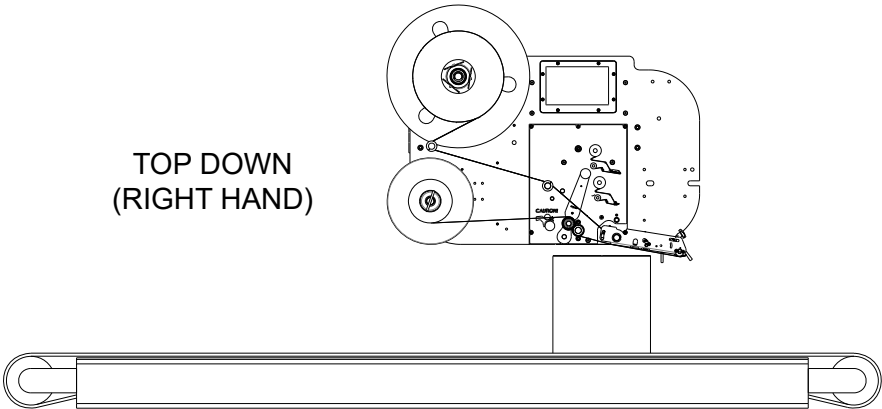
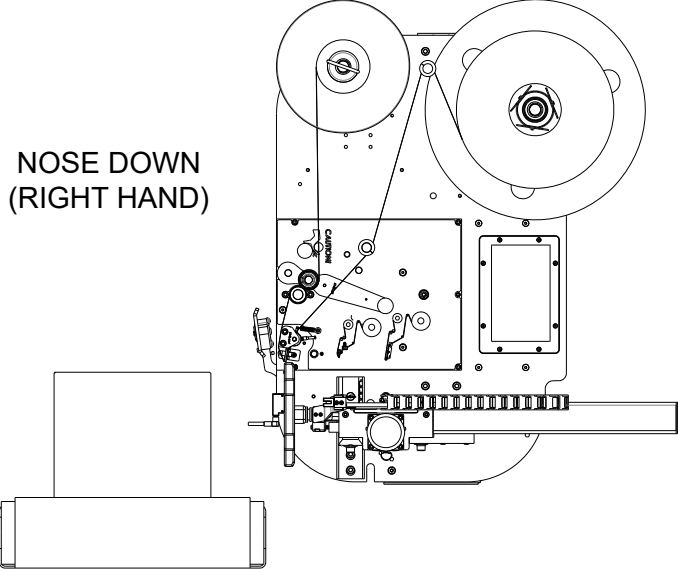
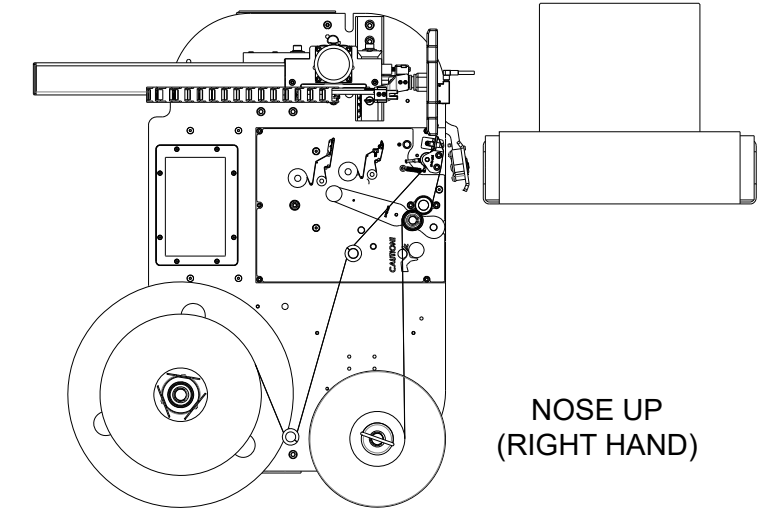

Step 2: System Alignment

WIPE

1. Verify leading edge of peel blade is parallel with product.
2. Verify label direction is parallel with conveyor direction.

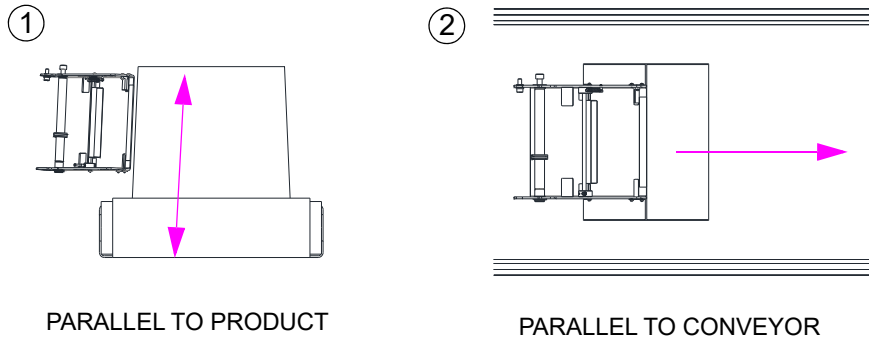

CONVEYOR MOUNTING

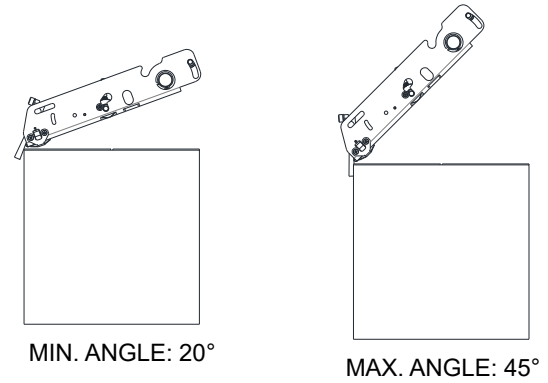

TAMP

Pad should extend and lay flat against product.

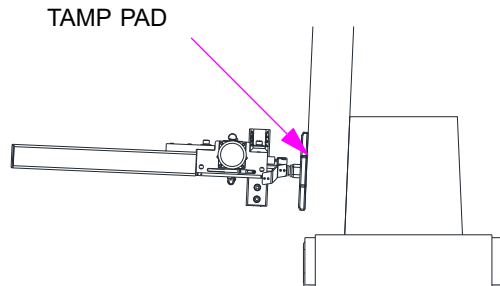

Step 3: Position Product Detector

MACHINE MOUNTING

WIPE

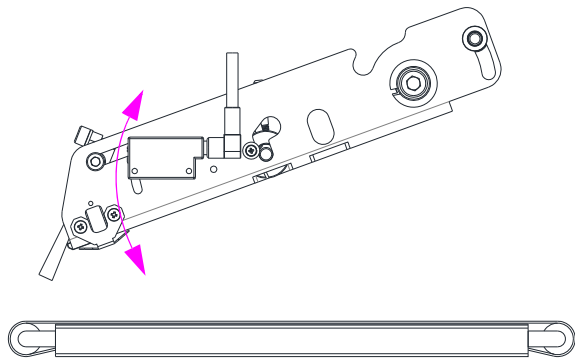

ALIGN WITH CONVEYOR

TAMP

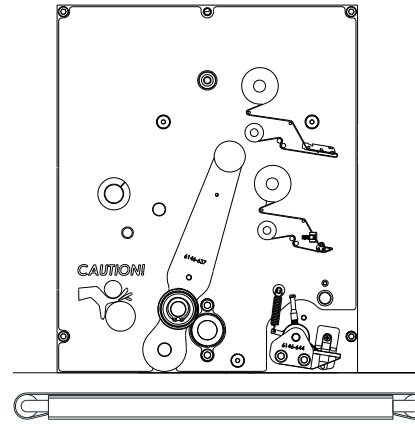

ALIGN WITH CONVEYOR

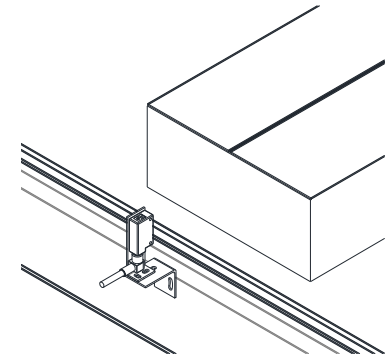

PRODUCT DETECTOR SETUP

1. To detect product present (Leading Edge), turn Light On/Dark On Selector to L. To detect product absent (Trailing Edge), turn Light On/Dark On Selector to D.
2. Turn Sensitivity Adjuster full counterclockwise.
3. Put a product on the conveyor at the expected distance from product detector during production.
4. Turn Sensitivity Adjuster clockwise until both Power Indicator and Output Indicator are on and solid when product is in front of sensor for Leading Edge, and absence of product for Trailing Edge.
5. Remove product.
6. Verify that detector does not sense movement beyond the far edge of the product. (If so, repeat steps 2 through 6.)

LIGHT ON/DARK ON
SELECTOR

SENSITIVITY
ADJUSTER

POWER
INDICATOR

OUTPUT
INDICATOR

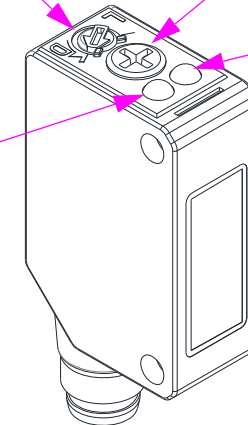

Step 4: Position Nip Roller

1. Using snap ring pliers, remove the outer Snap Ring and Washer.
2. Remove the Nip Roller.
3. Position the inner Snap Ring and Washer to allow the Nip Roller to be placed in the center of the liner.
4. Re-install the Nip Roller, followed by the Washer and then the Snap Ring. Seat the Snap Ring snugly.

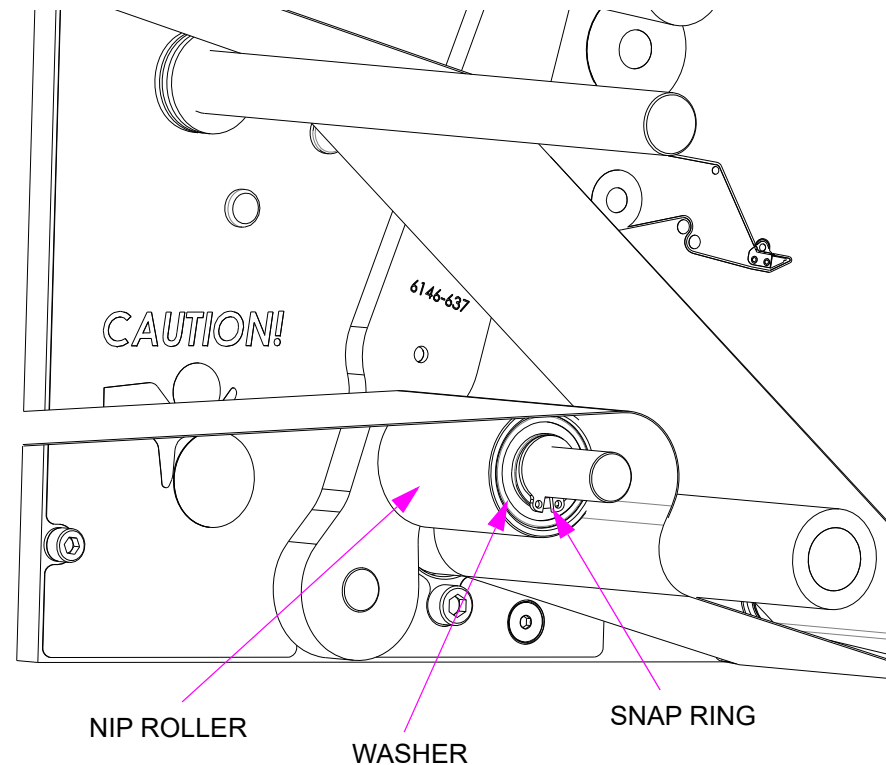

NOTE: The position of the nip roller is critical to the tracking of the liner through the system. Placing the nip roller too close to one edge of the liner will cause the liner to track in that direction. When used in the Side Apply application, some adjustment of the nip roller may be required on larger labels to compensate for the weight of the liner pulling downward throughout the system.

Step 5: Load Media

1. Push Supply Roll all the way against Unwind Hub.
2. Web Label Liner around Spindle 1.
3. Web Label Liner over Spindle 2.
4. Using the Hold-Down Lever to lift the Hold-Down Plate, feed the Label Liner under the Hold-Down Plate and through the gap sensor located at the end of the peel blade. (For Wipe Systems, ensure Label Liner runs under Peel Blade Mount.)
5. Ensure that Nip Lever is open (back toward label supply). Web Label Liner around Drive Roller and Nip Roller as shown.
6. Wrap Label Liner around rewind hub as shown.
7. Insert Rewind Clasp over Label Liner, and while holding the Liner, turn Rewind until the Liner grips the Rewind.

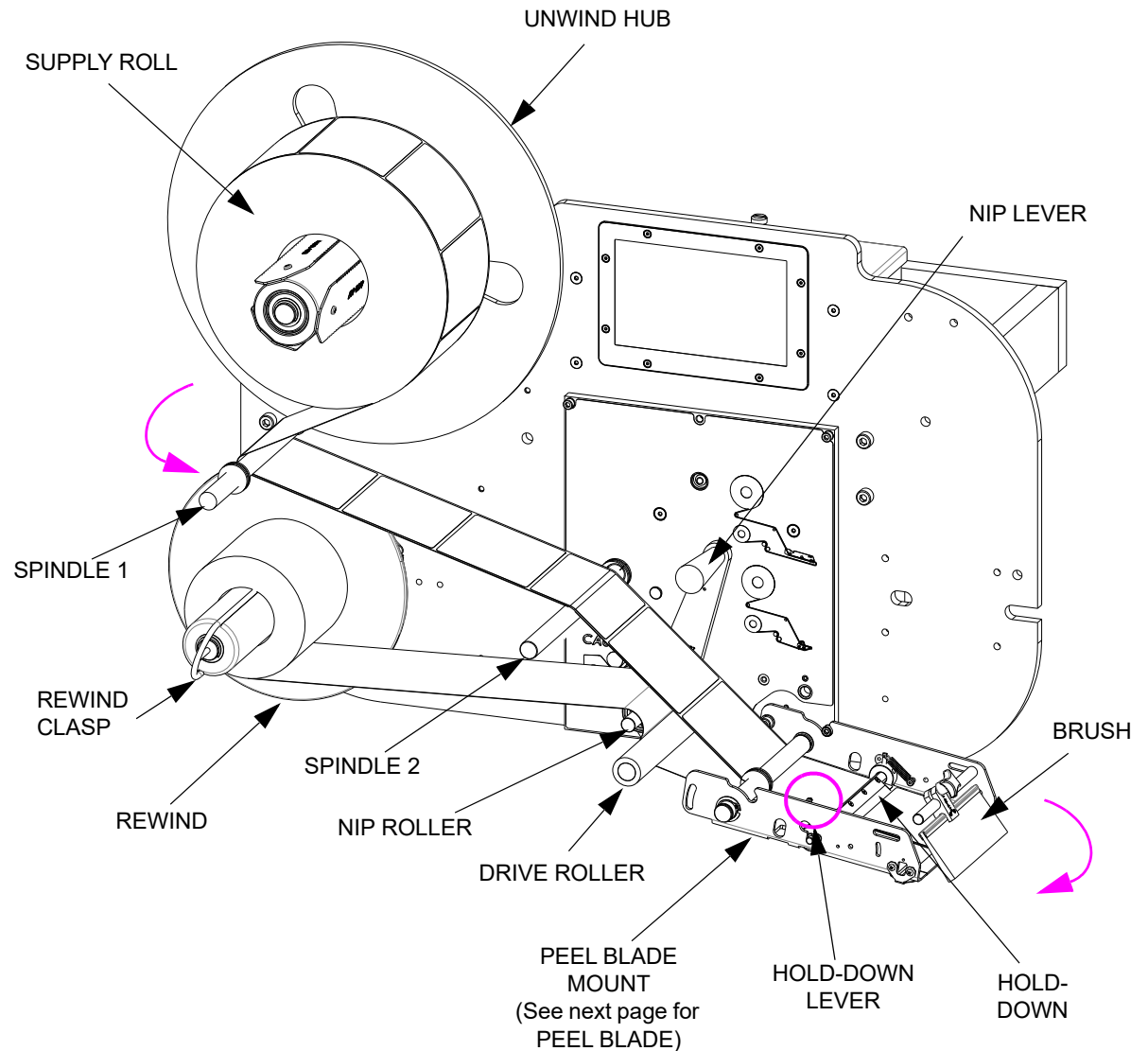

 **NOTE:** Remove the leading three feet of labels to reduce the chance of labels sticking to the rollers.

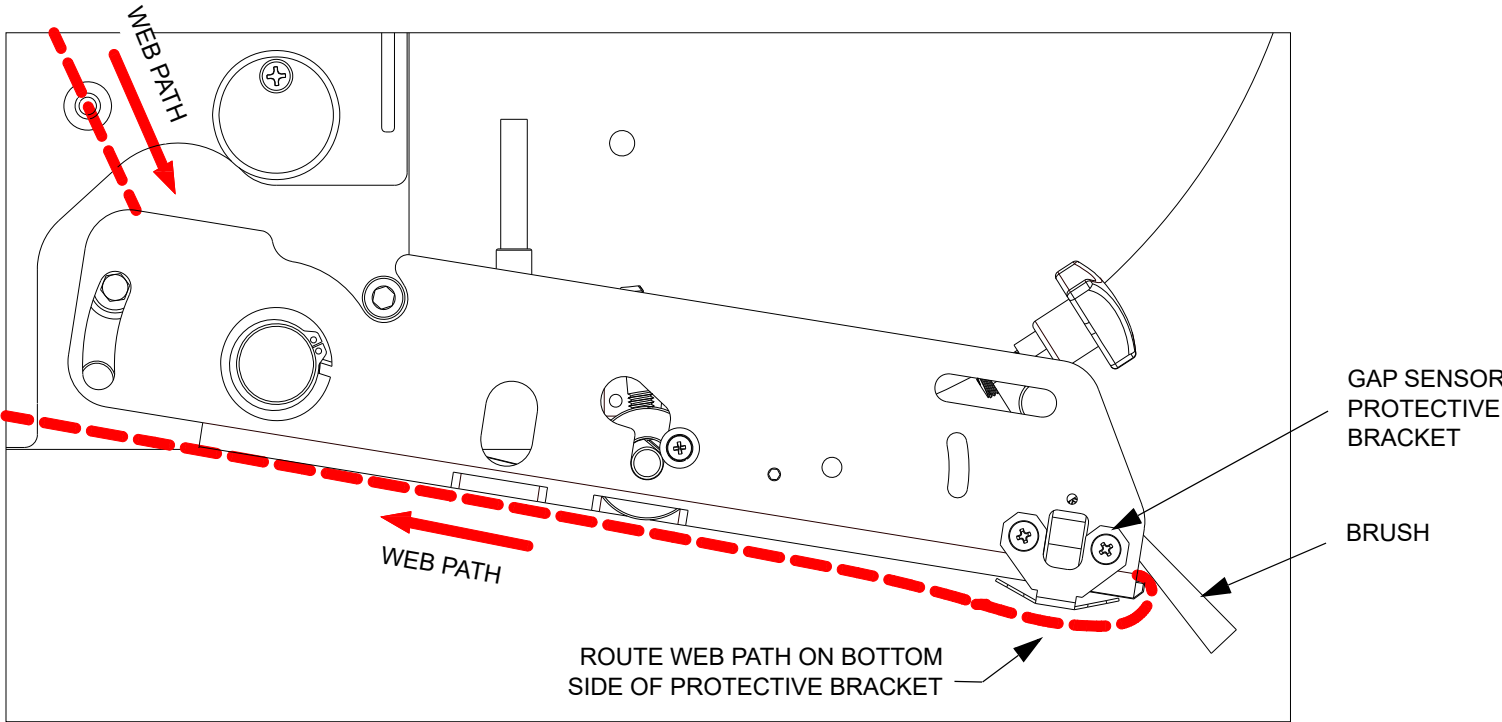

FOR TAMP APPLICATIONS

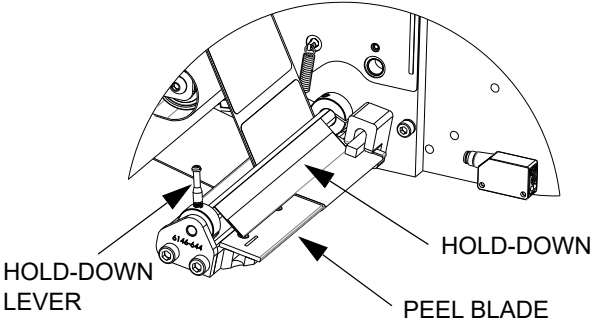

7000 Series Label Applicator

8. Press in all Spring Collars to guide the Liner.
9. Replace Brush to apply tight tension on the Liner.
10. The Nip Lever should be in the home position against the Drive Roller.

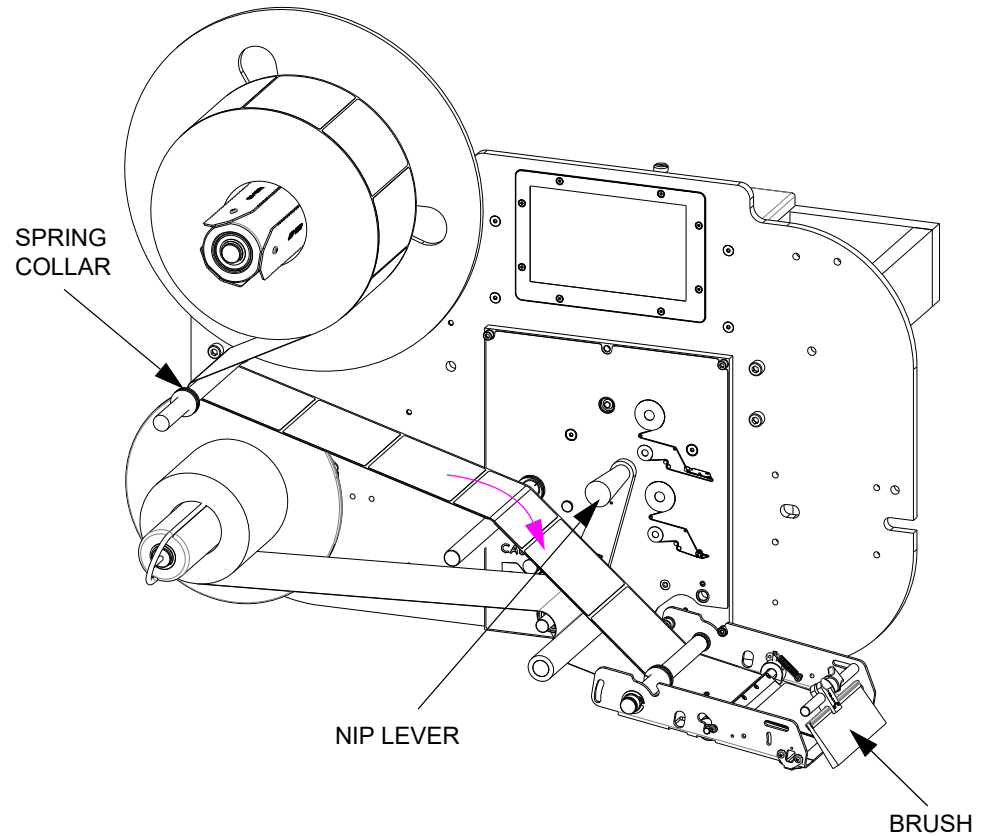

NOTE: This Label Applicator operates with type 1, 2, 3 and 4 labels. Be conscious of your application when ordering labels.

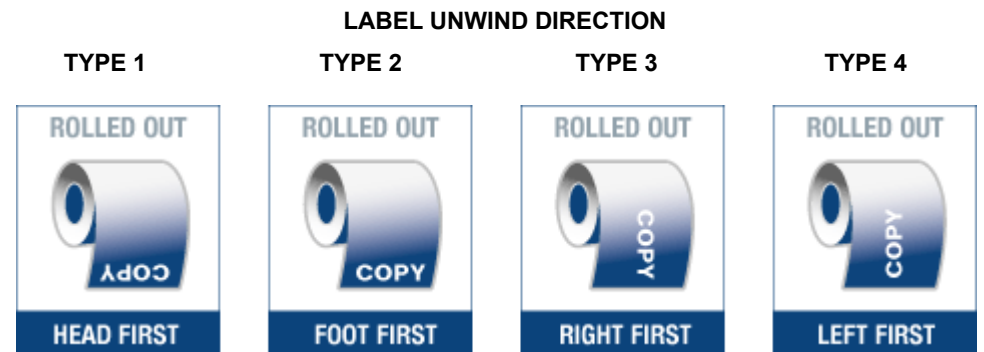

Step 6: Calibrate Gap Sensor

1. Remove leading label so only liner is below Gap Sensor.
2. Press **LABEL** from the Home Screen.
3. Press **Gap Sensor**.
4. Review the message, then press the message box to close **MSG 36**.
5. Press the **Calibrate** button.
 - Success: The Status LED flashes green, followed by MSG 37.
 - Failure: The Status LED flashes red, followed by MSG 38.

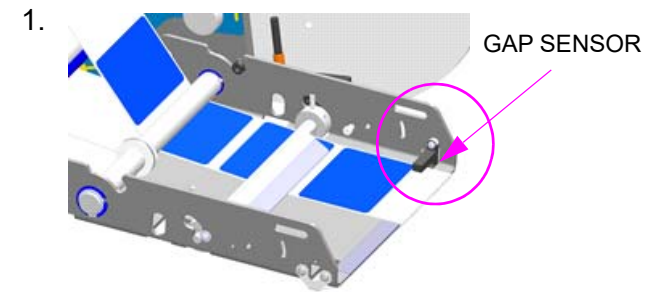
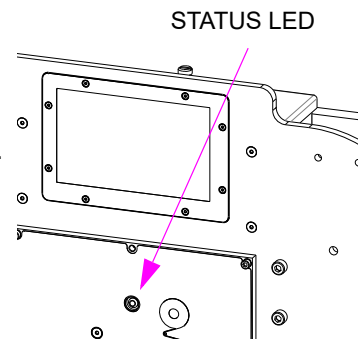

HOME SCREEN



Step 7: Set Speed

1. Press **Feed Speed** from the Label Menu.

2. Enter speed value in mm/s or Feet Per Minute (FPM) then press OK.

 **NOTE:** For a Wipe Application, insert the conveyor speed; for a Tamp Application, insert 762 mm/s (150 FPM). Adjust as needed.

Step 8: Set Dispense Position

1. Press **Dispense Position** from the Label Menu.

2. Enter a value for the **Dispense Position** in units of mm (1/100"). This value is the distance the liner has to travel after seeing Gap to align the next label at the edge of the peel blade. (Standard Labels: 12,7 to 19,1mm [0.5 to 0.75"])

3. Press the **Force Feed** button on the Label Menu to check that the value settings for Steps 5 to 7 have taken effect. One label will feed at the set speed and the next label will stop at the edge of the peel blade.

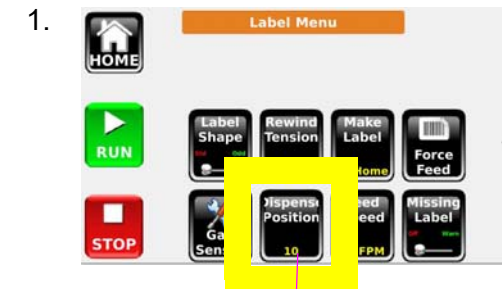

Step 9: Set Rewind Tension

Change **Rewind Tension** in the Label Menu to desired value. This setting will depend on the feed speed, label length and the liner material type (see LABEL MENU setup in Appendix B: Application Methods).



Step 10: Set Product Delay

1. Press **Setup** from the Home Screen, then press **JOB**.

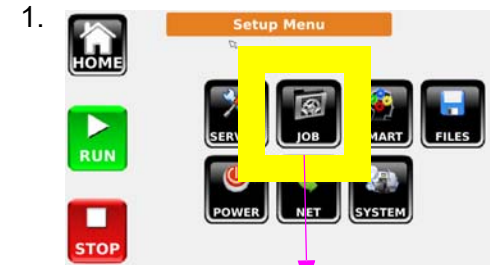

2. Press **Apply Delay**.



3. Set the delay from when the Product Detector triggers to when the Labeler applies a label, in milliseconds. Press OK. (See SETUP/JOB MENU for the appropriate applicator in Appendix B: Application Methods.)



Step 11: Set Apply Duration (Tamp Applicator only)

Press **SETUP** from the Home Screen, then press **JOB**.



NOTE: See Appendix B for more Actuator adjustments.

1. Set **Auto Retract** to 0.
2. Place a stationary product in front of the tamp pad.
3. Place system on-line by pressing the green **RUN** button.
4. Manually trigger product detector with your hand.
5. Adjust **Apply Duration**.
6. Repeat steps 4 and 5 until label adheres to product, but product is not hit too hard.

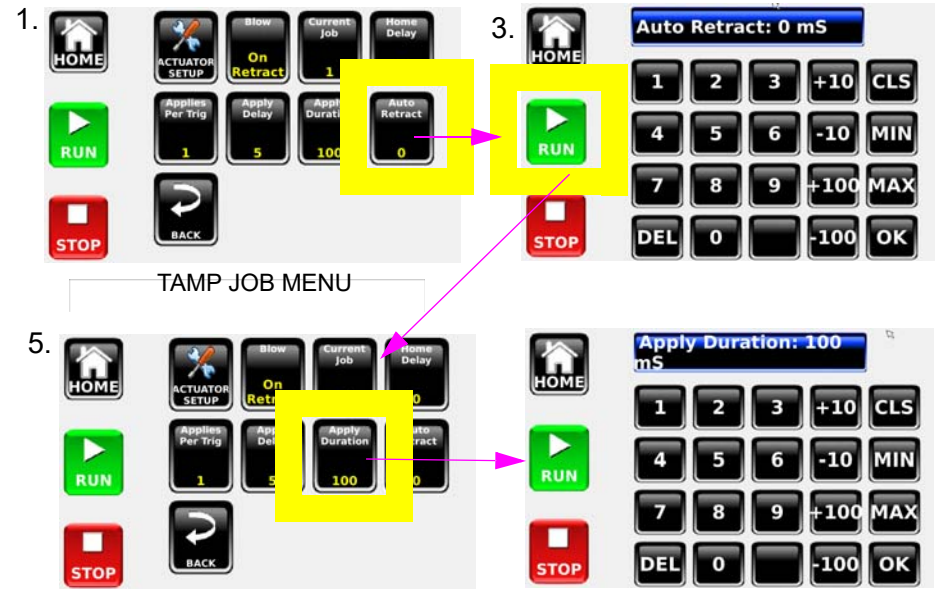

Step 12: Set Actuator Distance Limit (Tamp Applicator only)

Press **SETUP** from the Home Screen, then press **JOB**.



NOTE: The Distance Limit is a safety feature used to reduce damage to the machine and product.

1. Press **ACTUATOR SETUP**.
2. Measure the distance from tamp pad face to product face and add 12,7mm to 25,4mm (1/2" to 1").
3. Set **Distance Limit** to the whole number value.
4. Press **Distance Limit Fine** to make distance adjustments in 6mm (1/4") increments.

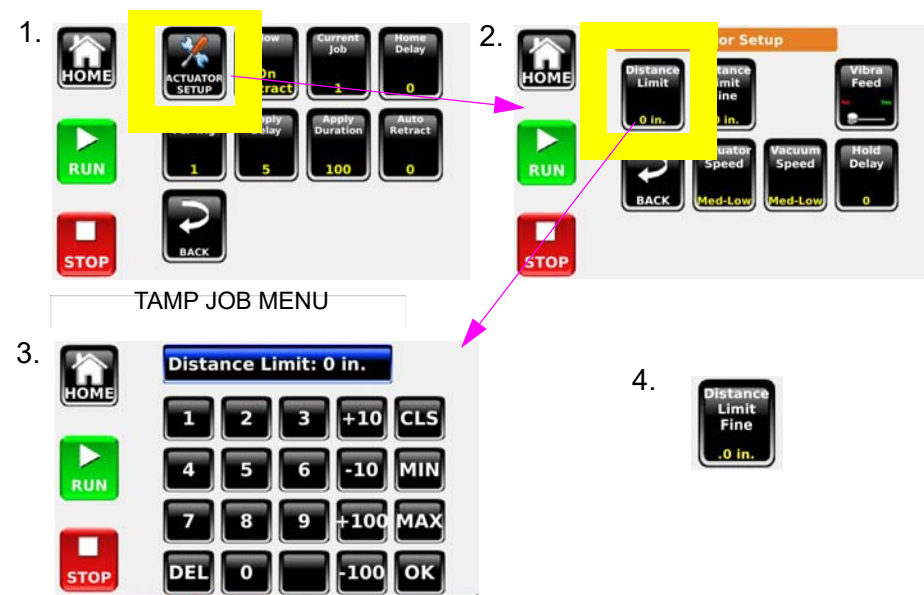

Step 13: Set the System Online

Press the **RUN** button from any screen. The system is ready to apply labels when the background turns green.

Press the **STOP** button from any screen to stop the system from applying a label.



NOTE: Any changes made to the settings are permanently saved when Home is pressed. If Home is not pressed, the setting will be temporary.

Section 3: Maintenance

Maintenance Schedule Chart

(See drawings on the following page.)

Action	Daily	Monthly	Annually
Clean Drive Roller		✓	
Replace Drive Roller *			✓
Replace Peel Blade *			✓
Clean Label Present and Auto-Retract Sensors (if present)	✓		
Clean Label Low Sensor (if present)		✓	
Clean Product Detector Sensor(s)		✓	
Inspect Drive Module Belt		✓	
Replace Drive Module Belt *			✓
Inspect Rewind Belt		✓	
Replace Rewind Belt *			✓
Replace Unwind Dancer Spring *			✓
Clean Tamp Pad	✓		
Inspect Vacuum Fan		✓	
Replace Vacuum Fan *			✓
Replace Unwind Dancer Arm Spindle *			✓
Clean Gap Sensor	✓		

* Indicates item is sold as part of a service kit. See “Appendix E: Part Numbers” on page 63.

Section 4: Troubleshooting

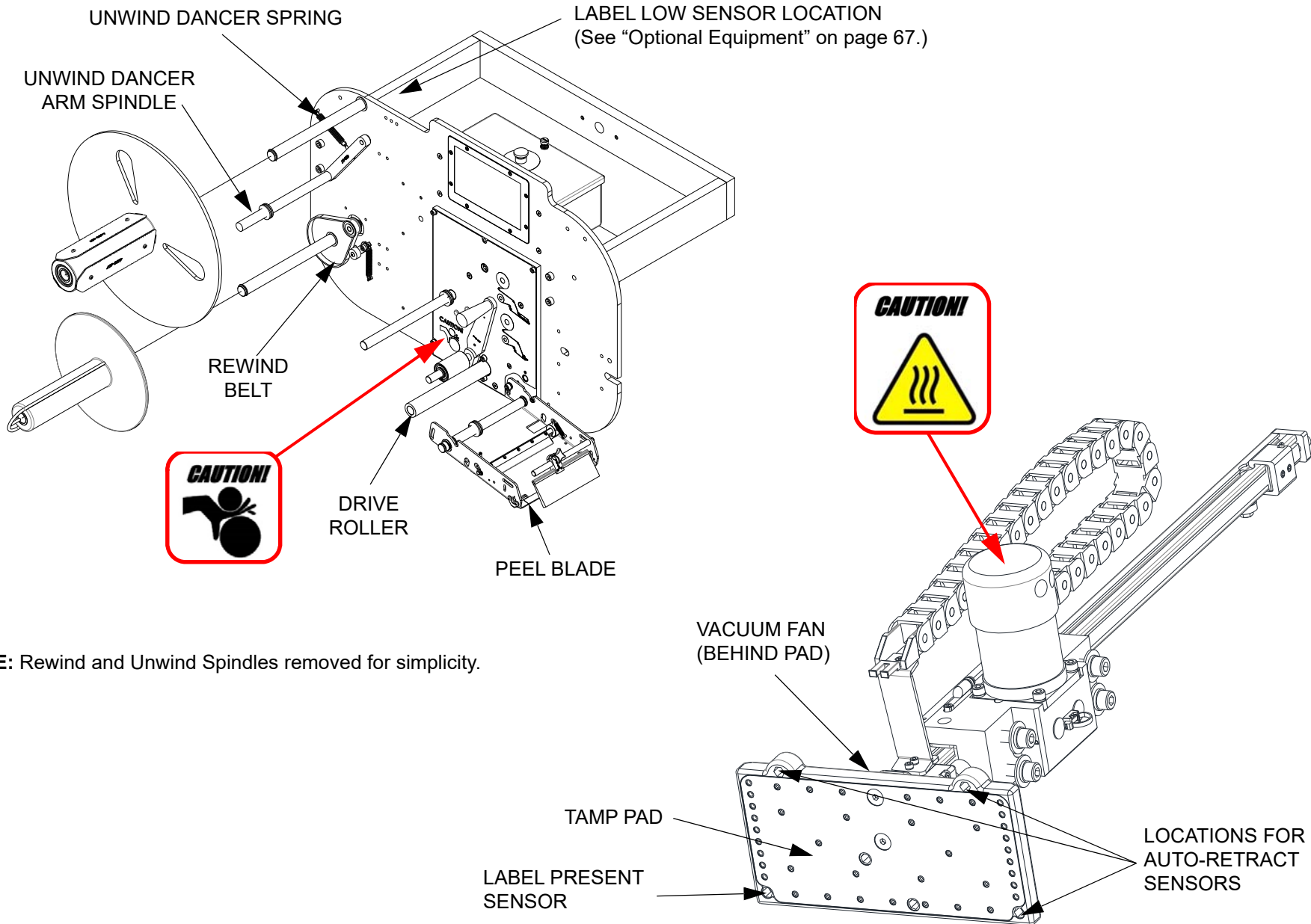

Common to All Systems

(Check these first before proceeding to specific system type.)

Problem	Possible Cause	Correction
Multiple labels are fed, without a pause between labels	Label gap sensor is not calibrated	Perform the label gap calibration procedure as seen in “Step 6: Calibrate Gap Sensor” on page 12.
	Label liner is not positioned inside label gap sensor	Set the web guides so that the liner passes through the label gap sensor.
	Label is not within 12,7mm (1/2”) of the liner edge	Change material which has the label’s edge to the liner’s edge less than 12,7mm (1/2”).
Drive roller is turning backwards, liner is pulled from rewind	Unit is incorrectly webbed	Re-web the label liner, as seen in “Step 5: Load Media” on page 9.
	Unit is not correctly configured for left-hand or right-hand	Confirm that the unit configuration is correct. (See “Appendix B: Application Methods” on page 35.)
Supply roll is signaling label low too soon	Label Low Sensor position incorrect	Unscrew the label Low Sensor, move it to a position farther away from the unwind supply roll core and screw into position.
	Label Low Sensor malfunction	Refer to “DIAGNOSTICS SCREEN” on page 22 to verify sensor functionality.
Calibration of Label Gap results in failure	Liner is too thick	This material may not be compatible with the unit’s standard sensor.
	Sensor is dirty	Remove sensor from peel blade and clean it with isopropyl alcohol.
	Sensor connection is faulty	Check Connector J8 on Controller Board (4750-350).
	Sensor is damaged	Replace sensor.

Wipe Systems

Problem	Possible Cause	Correction
Unit will not dispense a label when product detector is triggered	Unit is off-line or has an error condition	If no errors exist, press RUN button to place unit on-line. If errors exist, determine error type from the display and clear error condition. Attempt to go on-line by pressing the RUN button (this will also check for remaining errors).
	Cabling problem	Verify cabling per "Appendix C: Electrical Interface" on page 61.
	Product Detector field of view not set up	Verify set-up per "Step 3: Position Product Detector" on page 7.
Labels are wrinkled (or crumpled) on the product	Feed speed too high	Reduce Feed Speed per "WIPE Parameter Setup" on page 56.
	Peel blade angle is not correct	Set angle between 20° and 45°. Shorter labels require a steeper angle to the product surface. See "WIPE Mechanical Setup" on page 55.
	Wipe-on brush position is too close to peel edge	For labels longer than 50,8 mm (2"), move the brush away from the peel blade edge and angle to 45°.
	The hold-down plate on the peel blade has become loose. (Refer to picture in "Step 5: Load Media" on page 9.)	Tighten the hold-down plate on the peel blade to increase the tension on the Liner per "Step 5: Load Media" on page 9.
Liner tracking into the inner or outer guide, web travel is not straight, or excessive paper dust created	Web guides not set properly	Adjust guides per "Step 5: Load Media" on page 9.
	Nip Roller not centered on Label Liner.	Center Nip Roller on Label Liner.

Tamp Systems

Problem	Possible Cause	Correction
Unit will not actuate when product detector is triggered	Unit is off-line or has an error condition	If no errors exist, press RUN button to place unit on-line. If errors exist, determine error type from the display and clear error condition. Attempt to go on-line by pressing the RUN button (this will also check for remaining errors).
Label is on the tamp pad, but Actuator does not fire	Product detector not triggered by product	Refer to "DIAGNOSTICS SCREEN" on page 22 to verify that the product detector can repeatedly detect the product. Adjust sensor as necessary.
	Apply trigger occurred before label was on tamp pad	Increase distance of product detector from tamp pad to allow feeding to complete.
	Actuator malfunction.	Refer to "DIAGNOSTICS SCREEN" on page 22 to manually trigger the actuator.
Tamp pad is contacting product with too much force or for too long a duration	Auto-Retract delay time is too long	Decrease the Auto-Retract delay time to start the Actuator return sooner.
Multiple labels are fed to the tamp pad	Dispense position incorrect. Next label over-extending during end of feeding. Next label dislodges label on pad.	Decrease dispense position.
	Dispense position incorrect. Label not extending out of Label Applicator far enough to seat on tamp pad.	Increase dispense position.
	Gap sensor not calibrated, or dirty.	Clean gap sensor and recalibrate per "Step 6: Calibrate Gap Sensor" on page 12.
Labels are feeding into the edge of the tamp pad	Tamp pad position too low	Set tamp pad to a distance just below the peel blade. See Tamp Pad Adjustments in "Appendix B: Application Methods" on page 35.
	Actuator home sensor position too low	Move the home sensor to a position where the Actuator home is detected later.

Diagnostics

Press **Info** from the Home Screen, then press **DIAG**.



DIAGNOSTICS SCREEN

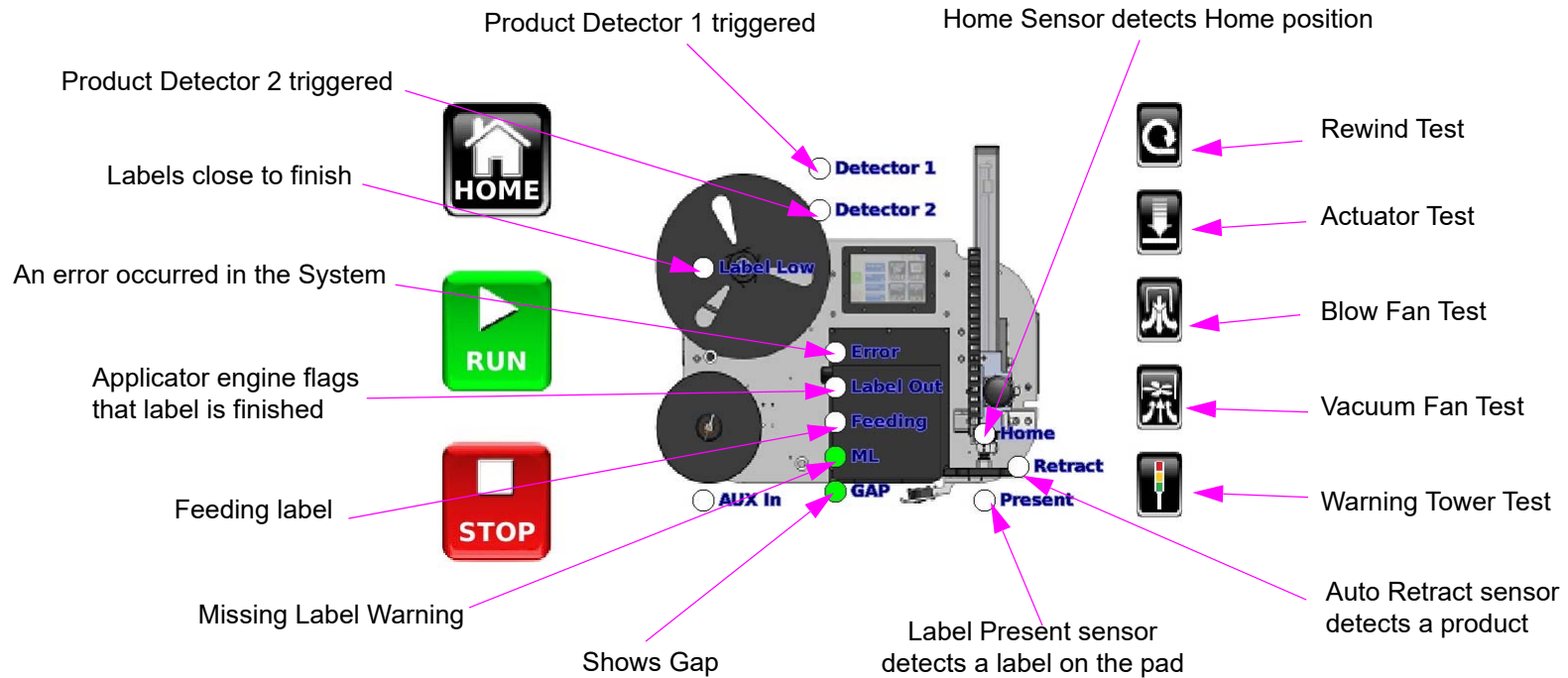

Information, Warning, Error, and Diagnostic Codes

Message Number	Type	Message	Reason
MSG 6	Error	LABEL OUT	Label Applicator has detected the end of the label supply.
MSG 9	Informational	MISSING LABEL DETECT	Label Applicator has detected a missing label.
MSG 10	Error	LABEL MODULE	Label Applicator has an error.
MSG 36	Informational	GAP SENSOR CALIBRATION	Instructions on how to calibrate the label gap sensor located on the peel tip.
MSG 37	Informational	CALIBRATION SUCCESS	Label gap sensor was properly calibrated.
MSG 38	Informational	CALIBRATION FAILURE	Label gap sensor was not properly calibrated. This can be due to liner thickness or opacity outside of the system specifications, a faulty connection to the sensor, or the optics require cleaning.



NOTE: For additional messages, errors and warnings, refer to the Trouble-Shooting section in the MCA Manual (404012).

Appendix A: System Specifications

General Specifications

Category		Parameter
Dimensions (with Yoke)		787mm (31") L x 686mm (27") H x 660mm (26") D
Weight	WIPE E-TAMP, E-WASA E-FASA Chi-Stand	36,7 kg (81 lbs) (includes yoke, no stand) 44,5 kg (98 lbs) (includes yoke, no stand) 45,8 kg (101 lbs) 37,6 kg (83 lbs)
Accuracy	E-TAMP, E-WASA, E-FASA, WIPE E-TAMP/BLOW WIPE - Line Encoder Enabled	±1,6mm (±0.06") ±2,4mm (±0.09") ±3,2mm (±0.130") (overall), ±1,6mm (±0.06") (at one speed)
Certifications		IEC 61000-6-2 2005/AC:2005 Immunity IEC 61000-6-4 2007/A1: 2011 Emission FCC Part 15b CSA CAN/CSA-C22.2 No. 62368-1:2014 UL62368-1:2014, N 62368-1:2014/AC:2017-03 IEC 62368-1:2014, CE
Supply Roll Capacity		355,6mm (14") OD
Core		76,2mm (3") ID
Label Length	WIPE - Line Encoder Enabled	25,4mm (1") Min. to 558,8mm (22") Max. 25,4 mm (1") Min. to 152,4 mm (6") Max.
Label Width	Narrow Web Wide Web	12,7mm (0.5") Min. to 152,4mm (6") Max. 12,7mm (0.5") Min. to 228,6mm (9") Max.
Product Rate	WIPE E-TAMP E-TAMP/BLOW E-FASA E-WASA	800 PPM Max. 120 PPM Max. 55 PPM Max. Single Apply: 52 PPM Max. Dual Apply: 28 PPM Max. Dependent on label length, print speed and product spacing
Line Speed	WIPE WIPE - Line Encoder Enabled E-TAMP, E-TAMP/BLOW E-FASA E-WASA HIGH SPEED TAMP	1524 mm/s (300 FPM) Max. 1016 mm/s (200 FPM) Max. 762 mm/s (150 FPM) Max. 381 mm/s (75 FPM) Max. 635 mm/s (125 FPM) Max. 1524+ mm/s (300+ FPM) Max.
Temperature		5°C - 40°C (41°F - 104°F)
Humidity		10 to 85% Relative Humidity, Non-Condensing



NOTE: PPM refers to Products Per Minute.

NOTE: Labels 1" x 1" and smaller require testing to ensure quality placement and speed.

Electrical Specifications

Category	Nominal	Minimum	Maximum
AC Voltage Supply	100 - 240 VAC, 4.2A 50/60 Hz	90 VAC 47 Hz	264 VAC 63 Hz
Product Detector	Low: 0 to 3 VDC High: 3 to 5 VDC Supplies 24 VDC	0 VDC	24 VDC
Product Detector Pulse Width	10 mS	1 mS	Infinite
Auxiliary Output Warning Tower	0 and 24 VDC 1 Amp sinking	0 VDC 0 mA	24 VDC 3 Amps sinking
Discrete Inputs (Optional)	Low: 0 to 10 VDC High: 10 to 24 VDC	0 VDC	26 VDC
Discrete Input Pulse Width Detection	10 mS	1 mS	Infinite
Discrete Outputs (Optional)	0 - 24 V AC/DC at 150 mA	0 V AC/DC, 13 ohms	30 V AC/DC at 400 mA

Performance Specifications

WIPE Application	Label Size	PPM Maximum
WIPE	50,8mm x 25,4mm (2" x 1")	500 PPM*

* WIPE Maximum PPM greatly relies on label size, line speed and product size.

10 or 20 in. E-TAMP Labeler Application	Label Size	Stroke Distance (Baseplate edge to product)	PPM Maximum
Side Orientation (Nose-Down)	101,6mm x 50,8mm (4" x 2")	101,6mm (4"), HIGH Actuator Profile	85 PPM
Side Orientation (Nose-Down)	101,6mm x 50,8mm (4" x 2")	76,2mm (3"), HIGH Actuator Profile	94 PPM
Side Orientation (Nose-Down)	101,6mm x 50,8mm (4" x 2")	38,1mm (1.5"), HIGH Actuator Profile	102 PPM

10 in. E-FASA Labeler Application	Label Size	Stroke Distance (Baseplate edge to product)	PPM Maximum
Dual Panels - Front & Side	101,6mm x 50,8mm (4" x 2")	114,3mm (4.5"), HIGH Actuator Profile	28 PPM
Dual Panels - Side & Rear	101,6mm x 50,8mm (4" x 2")	114,3mm (4.5"), HIGH Actuator Profile	24 PPM
Single Panel - Front Only	101,6mm x 50,8mm (4" x 2")	114,3mm (4.5"), HIGH Actuator Profile	52 PPM
Single Panel - Rear Only	101,6mm x 50,8mm (4" x 2")	114,3mm (4.5"), HIGH Actuator Profile	46 PPM
Dual Panels - Front & Side	101,6mm x 152,4mm (4" x 6")	114,3mm (4.5"), HIGH Actuator Profile	18 PPM
Dual Panels - Side & Rear	101,6mm x 152,4mm (4" x 6")	114,3mm (4.5"), HIGH Actuator Profile	16 PPM
Single Panel - Front Only	101,6mm x 152,4mm (4" x 6")	114,3mm (4.5"), HIGH Actuator Profile	44 PPM
Single Panel - Rear Only	101,6mm x 152,4mm (4" x 6")	114,3mm (4.5"), HIGH Actuator Profile	40 PPM

20 in. E-FASA Labeler Application	Label Size	Stroke Distance (Baseplate edge to product)	PPM Maximum
Dual Panels - Front & Side	101,6mm x 152,4mm (4" x 6")	355,6mm (14"), MED-LOW Actuator Profile	10 PPM
Dual Panels - Side & Rear	101,6mm x 152,4mm (4" x 6")	355,6mm (14"), MED-LOW Actuator Profile	12 PPM
Single Panel - Front Only	101,6mm x 152,4mm (4" x 6")	355,6mm (14"), MED-LOW Actuator Profile	26 PPM
Single Panel - Rear Only	101,6mm x 152,4mm (4" x 6")	355,6mm (14"), MED-LOW Actuator Profile	24 PPM

E-WASA Labeler Application	PPM Maximum
152,4mm (6") Length WASA	11 PPM
203,2mm (8") Length WASA	10 PPM
254mm (10") Length WASA	9 PPM
304,8mm (12") Length WASA	8 PPM

7000 Series Label Applicator

Wipe 152,4mm (6")

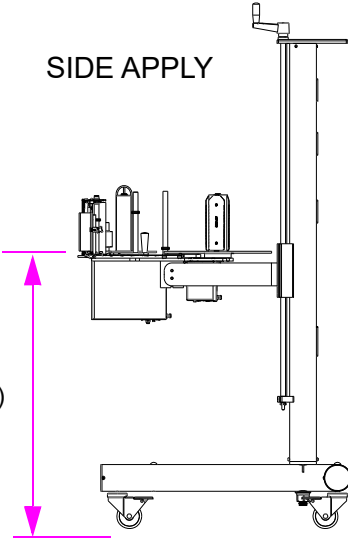
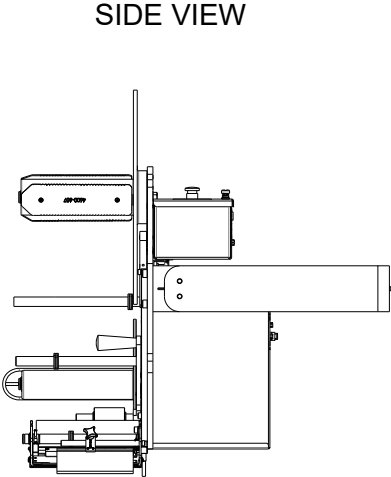
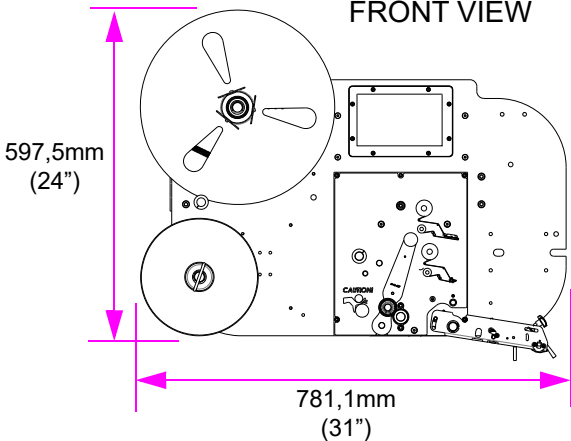
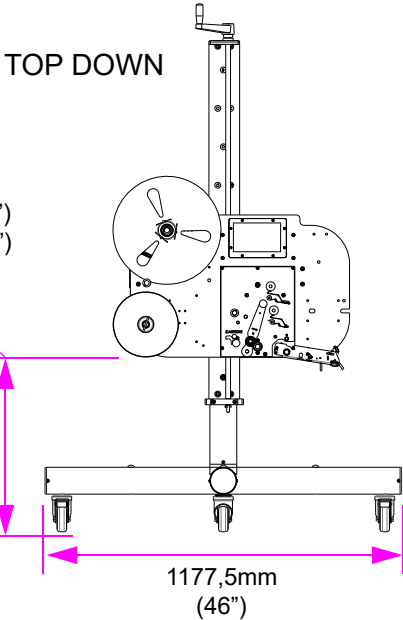
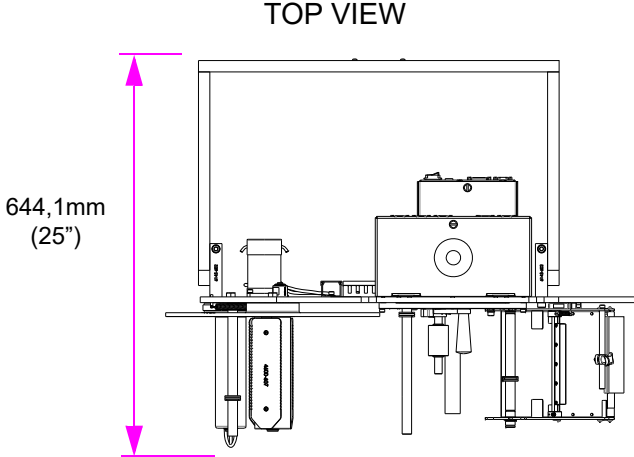

E-TAMP & E-TAMP/BLOW

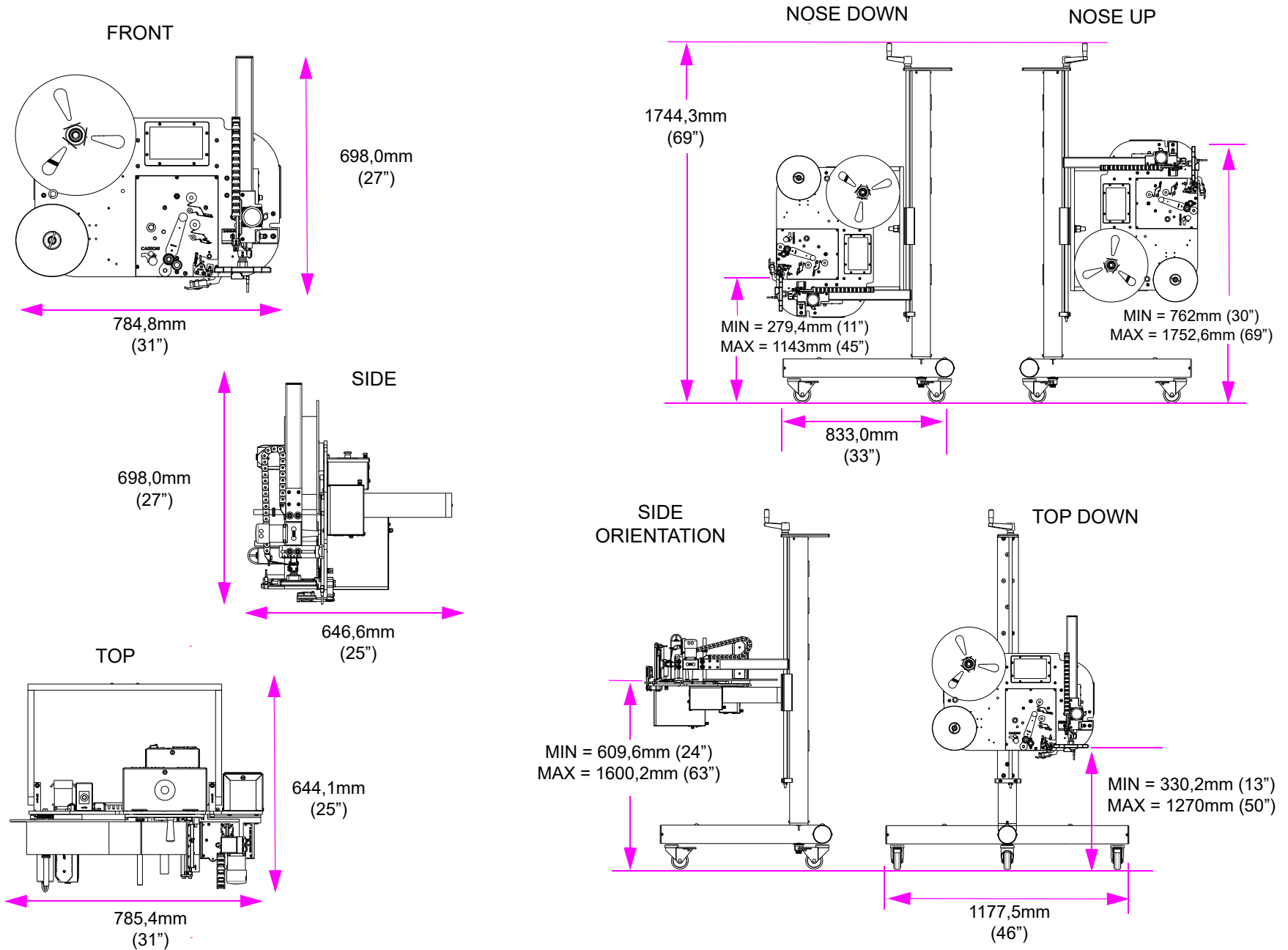

7000 Series Label Applicator

E-FASA 10 in.

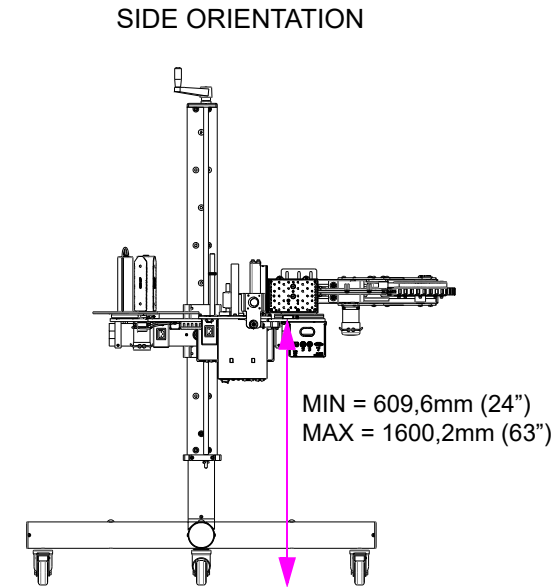
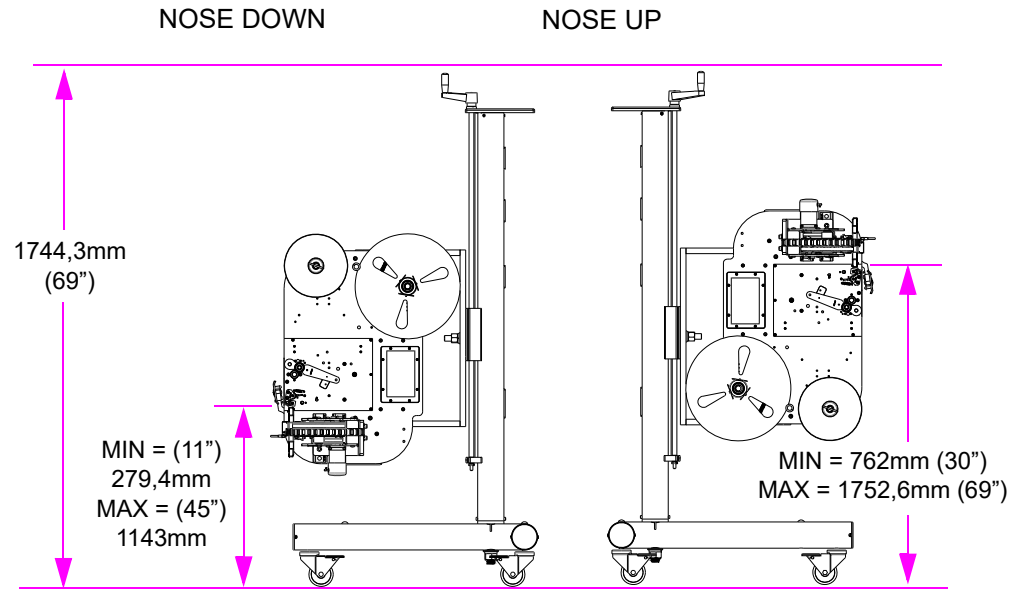
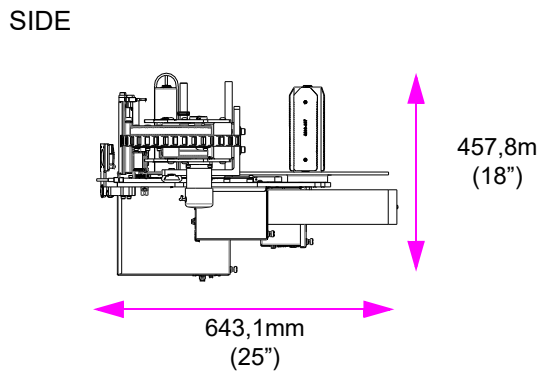
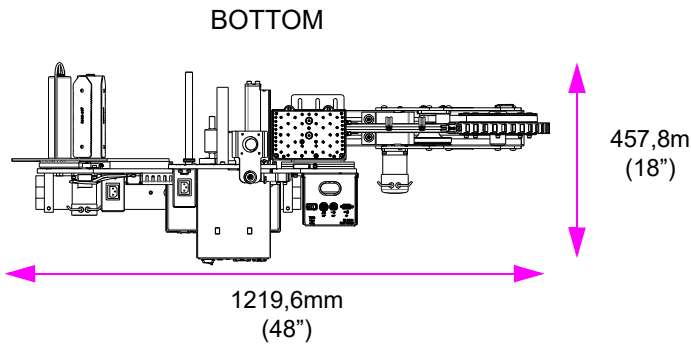
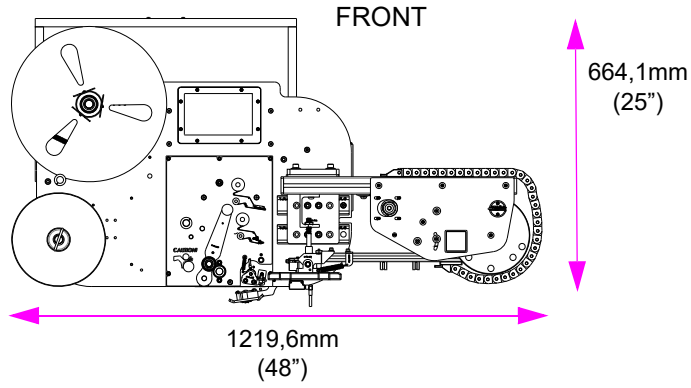

7000 Series Label Applicator

E-WASA

FRONT

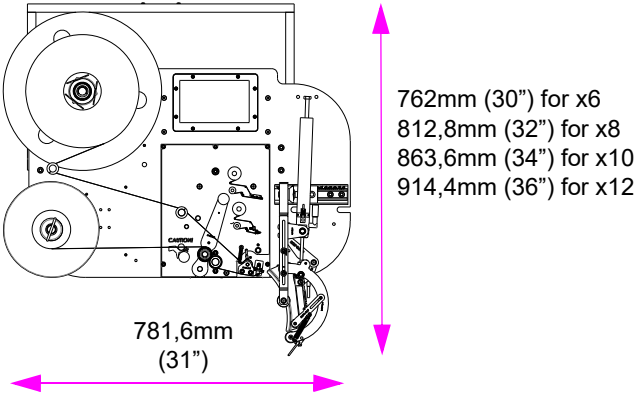

BOTTOM

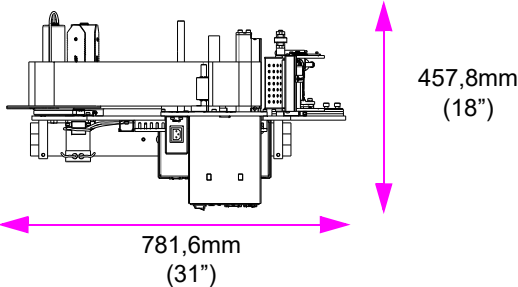

SIDE

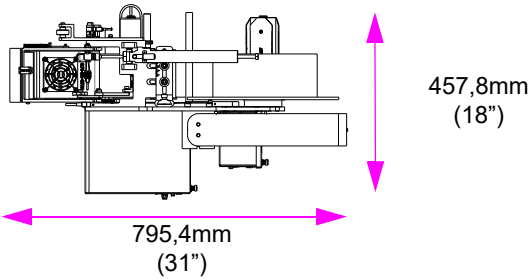

SIDE ORIENTATION

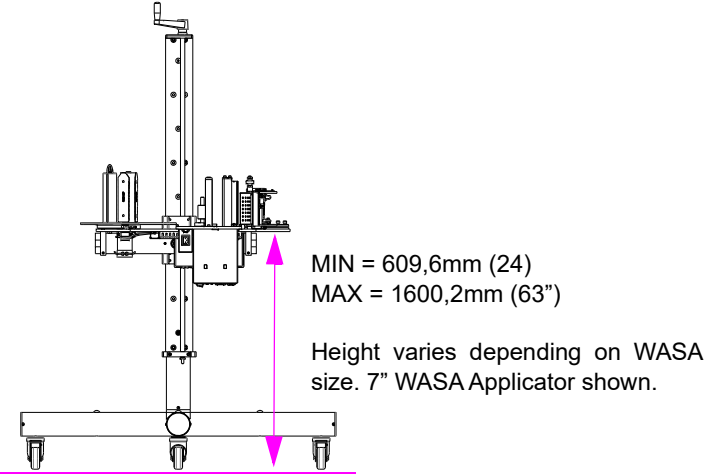

TOP-DOWN

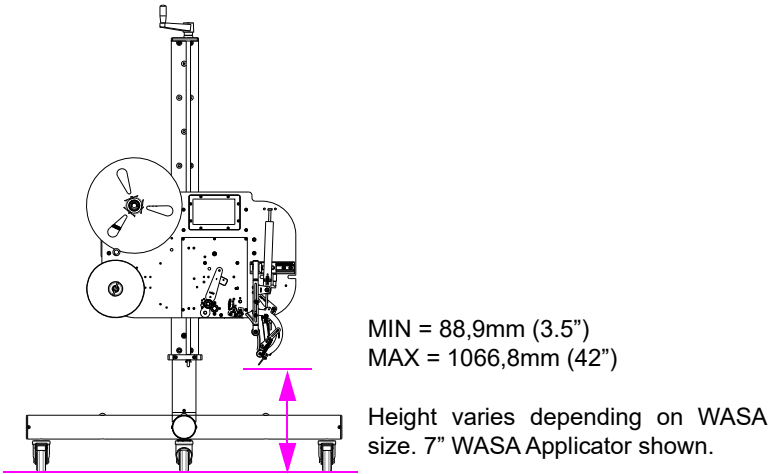

7000 Series Label Applicator

Standard T-Base Stand (CHI, 54" Upright)

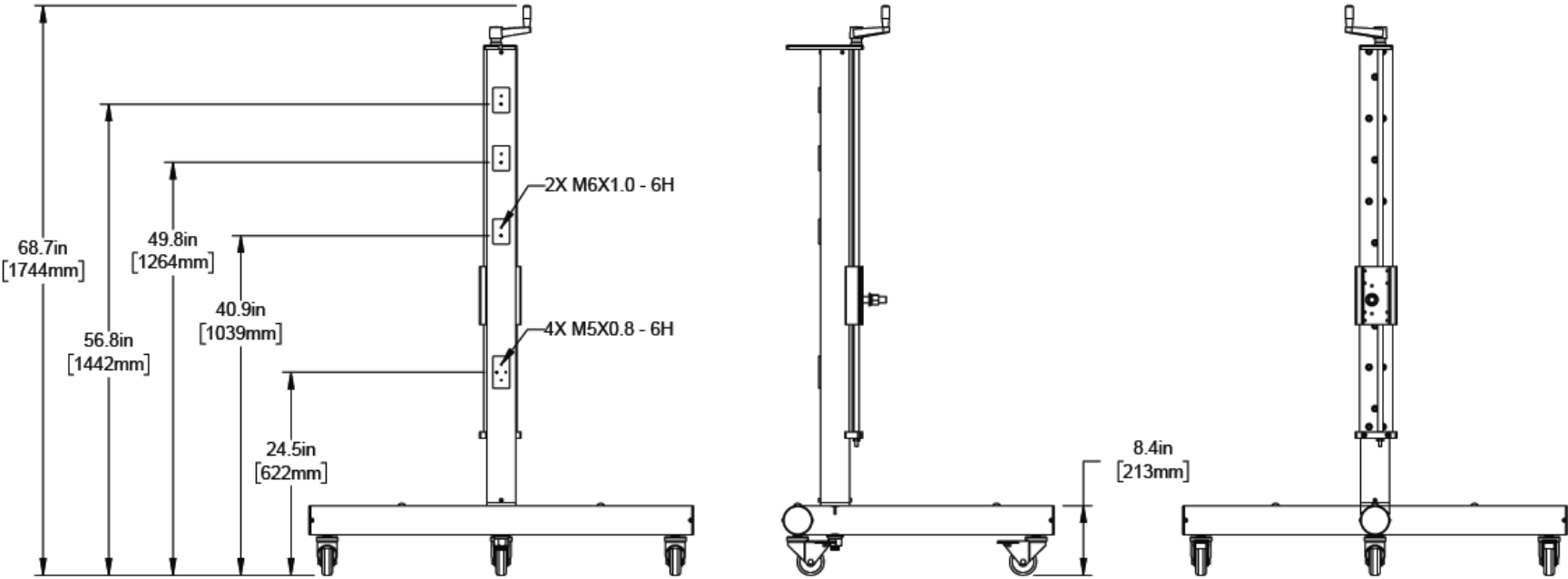
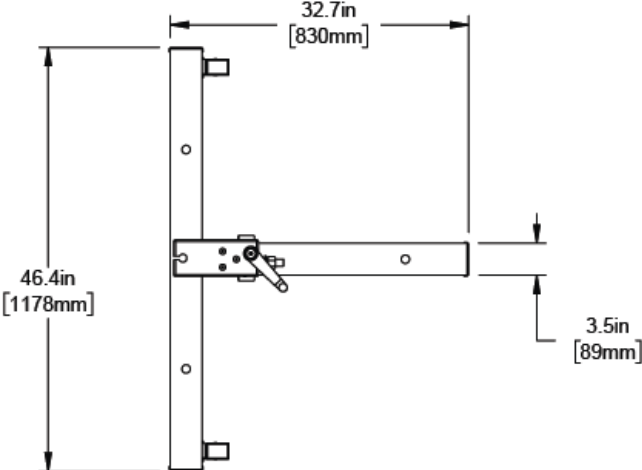

7000 Series Label Applicator

Floor Mount Stand (54" Upright)

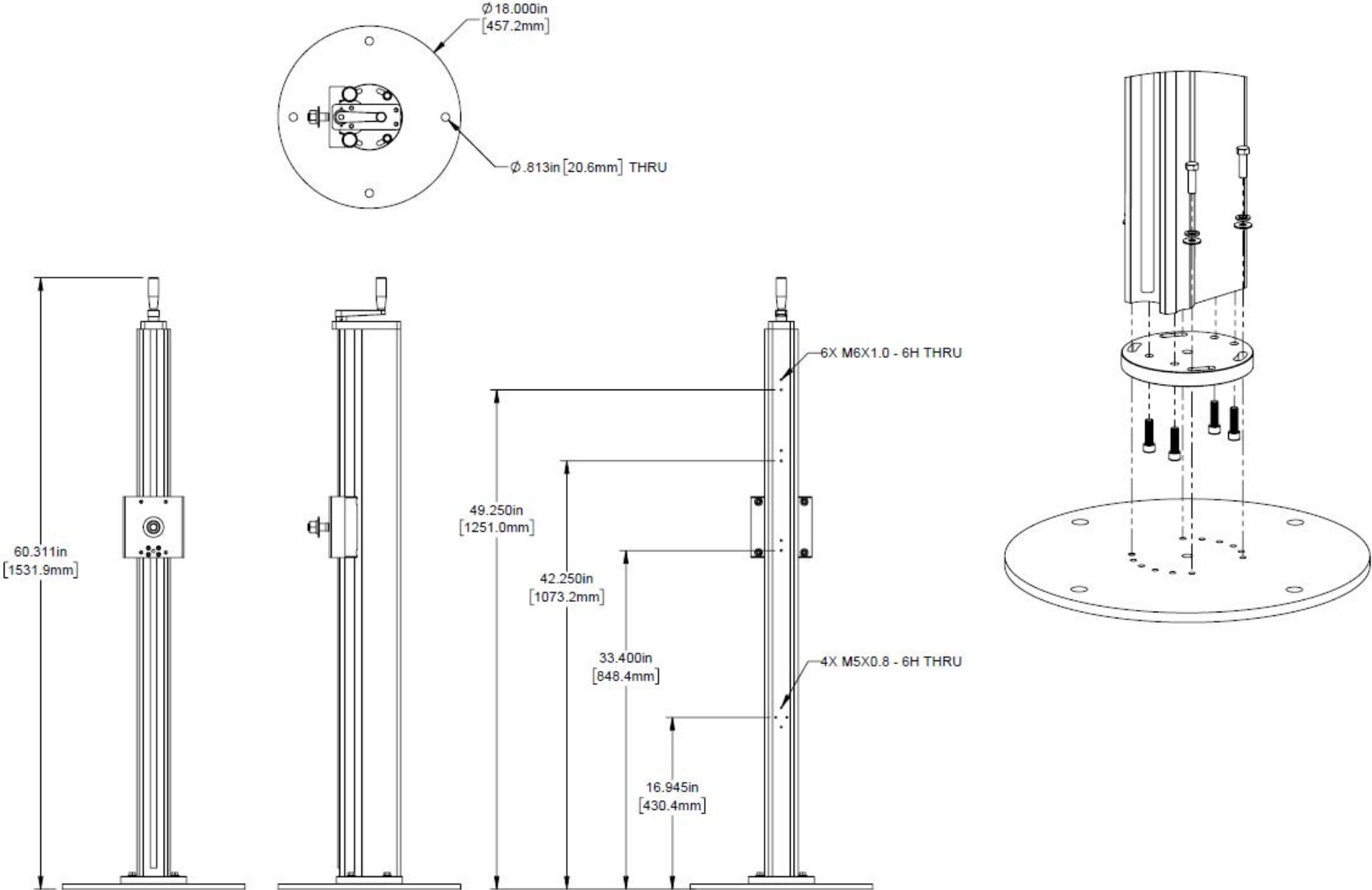

7000 Series Label Applicator

Heavy Duty T-Base Stand (54" Upright)

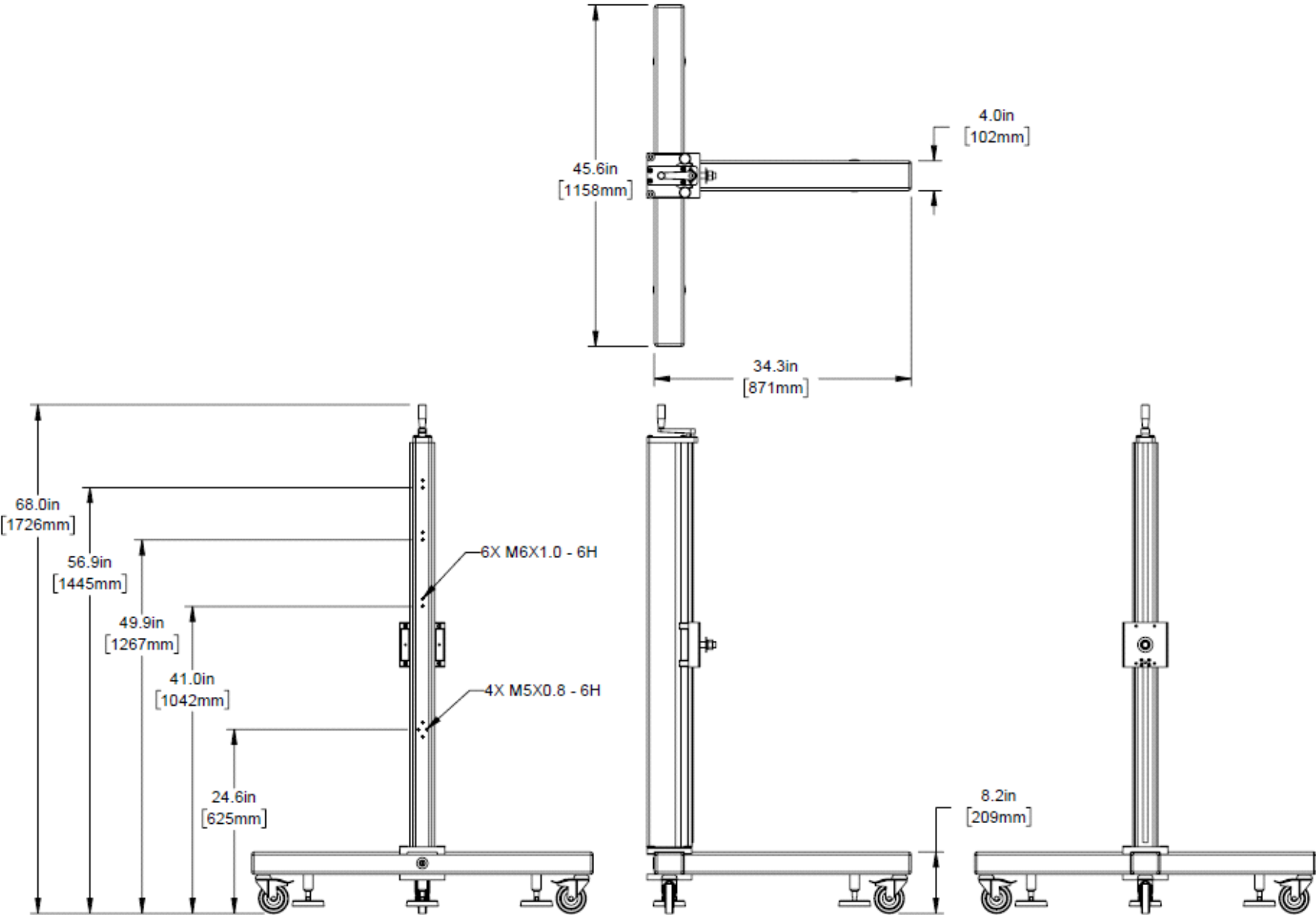

7000 Series Label Applicator

Heavy Duty U-Base Stand (54" Upright)

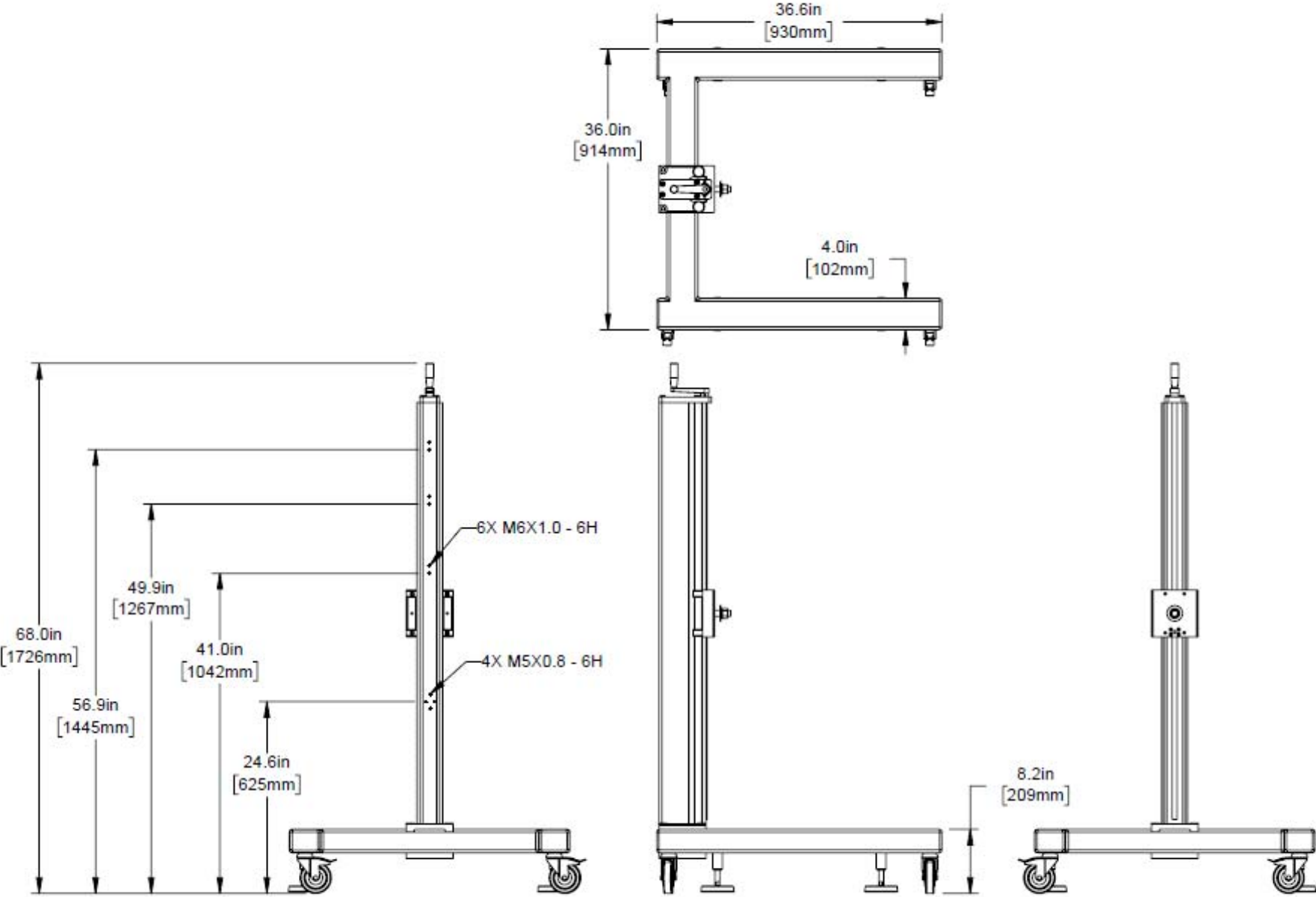

Appendix B: Application Methods

E-TAMP Mechanical Setup

ALIGN TO PEEL BLADE

1. Loosen both screws on the dovetail slider (A).
2. Slide actuator assembly toward and away from peel blade until there is approximately 3,2mm (1/8") gap.
3. Tighten both screws (A).

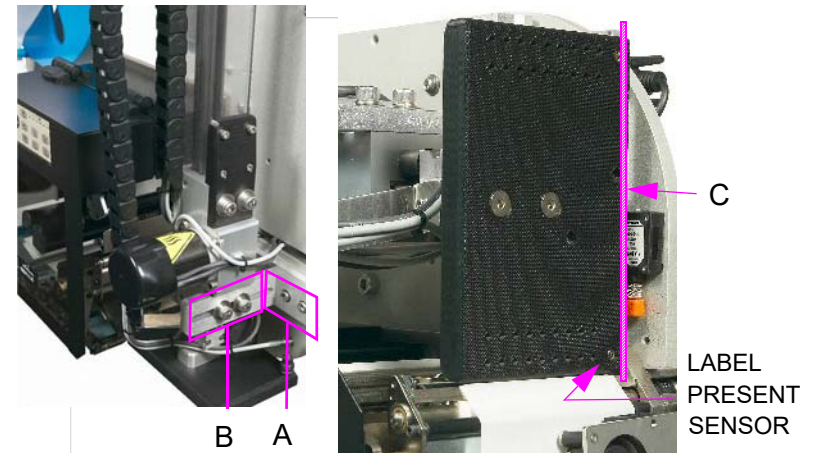

ALIGN LABEL WITH TAMP PAD

1. Loosen both screws on the tamp actuator L-bracket (B).
2. Slide the actuator assembly toward and away from the baseplate until the label present sensor will be covered by a fed label.
3. Tighten both screws on the tamp actuator L-bracket (B).

ALIGN TAMP PAD HEIGHT

1. Loosen the jam screw on the actuator rod.
2. Adjust the bumper height by turning the bumper so that the face of the peel blade is 1,6mm (1/16") **BEYOND** the peel blade.
3. Power on the Label Applicator to verify tamp pad home position.
4. Tighten the jam screw.

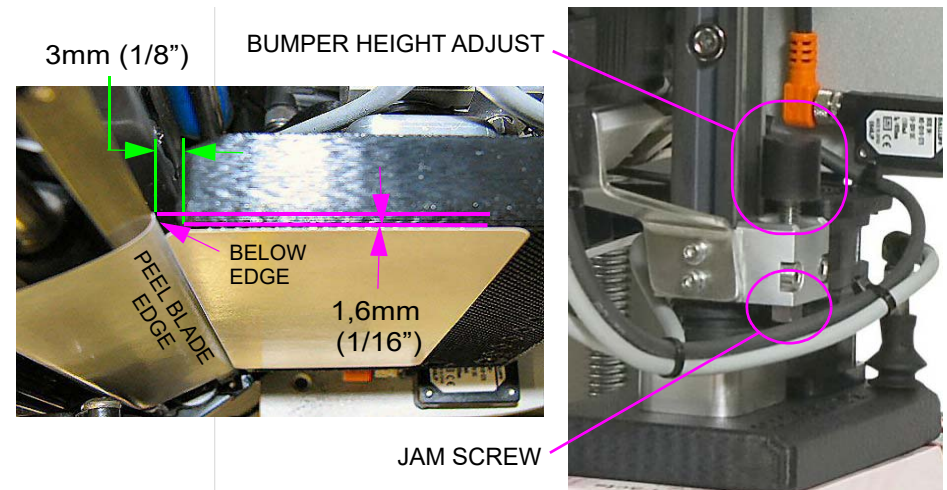

E-TAMP Parameter Setup

E-TAMP applications allow the label to be placed on the Top, Side or Bottom of a product. Typically, these are applying only one label to a product, but two can be applied as well.



LABEL MENU - Enter LABEL Menu from the Home Screen.

Std for rectangular labels with 3,2mm (1/8") gap or **Odd** for any shape label that passes gap sensor.

Sets the amount of tension applied to the rewind on a feed cycle. Set lower for speeds less than 100 FPM or labels shorter than 101,6mm (4").

Sets the distance the liner has to travel after the gap for the next label to align at the edge of peel blade. For standard labels usually set to 12,7mm to 19,1mm (0.5" to 0.75").

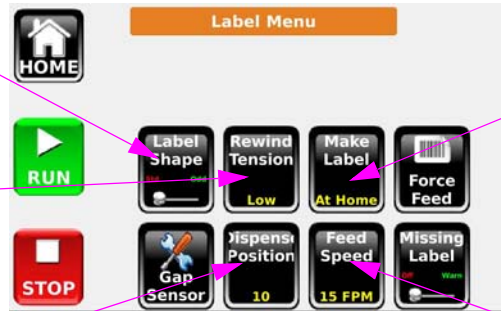

Determines the label generation mode. For slow applications, like pallets, make this **P1 Detect**. This will reduce the time the label adhesive is exposed to air and drying. For highest throughput, use **At Home**. Use **P2 Detect** for the highest accuracy (by using two detectors) when feed on demand is required. **Then Apply** feeds a label when actuator is at Home position, then applies immediately.

Depends on the product speed and PPM. Set for fastest throughput for the application.



SYSTEM MENU - Enter SYSTEM Menu from the Setup Menu.

Sets the rewind motor and the drive module motor direction.

Set to the length of the actuator.

Sets the direction of the Actuator motor. This setting matches the A/B configuration of the actuator.

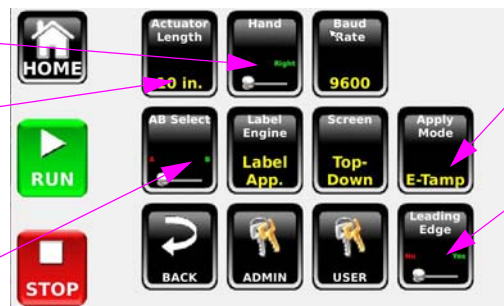

E-Tamp will be chosen for this application.

Yes will offset the label placement from the front. If the product lengths vary, and the label needs to be placed off of the trailing edge of the product, set to **No**.



SMART MENU - Enter SMART Menu from the Setup Menu.

Determines if the system is being used with the optional Label Present sensor.

Determines measurement units (Standard or Metric).

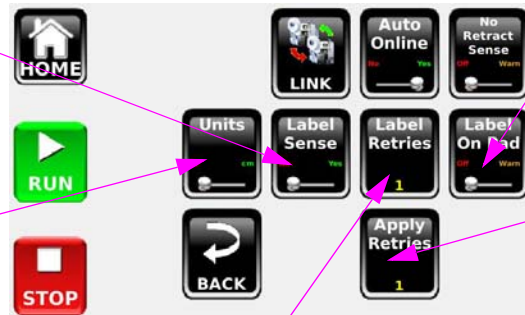

Provides a warning if the system is online with a prior label on the tamp pad. Helps avoid a potential label to product mismatch.

Determines how many times the system will attempt to apply the same label. The available options are **1, 2, 3** and **Infinite**. To ensure a 1 Label to 1 Product match, set this to 1.

Determines how many times the label will be fed without an application. The available options are **1, 2, 3** and **Infinite**. To ensure a 1 Label to 1 Product match, set this to 1.



SETUP/JOB MENU - Enter JOB Menu from the Setup Menu.

Keep as small as possible by locating the product sensor as close to the peel blade as possible. Exception - if print on demand is used.

Controls the extension stroke time. Set Auto-Retract to zero to properly adjust this time, then re-enable Auto Retract.

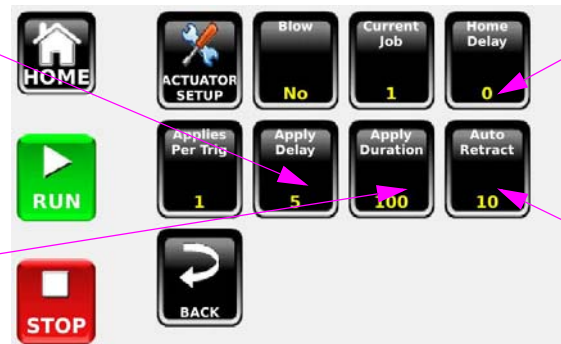

Most E-Tamp applications will not need much Home Delay. Large label sizes will benefit with a minimal delay of 20 mS to 100 mS.

If installed, the Auto-Retract (AR) time depends on the Actuator Speed. Speeds higher than **Medium** should not use the AR. **Low** to **Medium** speeds benefit from AR, and typical values range from 1 mS to 100 mS.

ACTUATOR SETUP MENU

Press **ACTUATOR SETUP** from SETUP/JOB Menu.

Sets the furthest extension of the tamp for the application with steps of one inch. Use this limit if the product distance to the labeler is consistent.

Sets the furthest extension of the tamp with 6mm (1/4") steps.

Sets the overall speed of the Actuator to five discrete values, and depends on the application speed and through put.

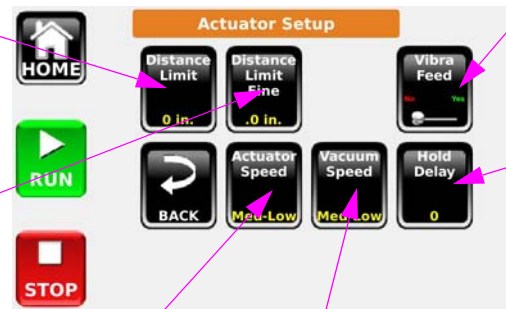

If enabled, the pad vibrates during label feed to help thicker labels or with stronger adhesive feed on the pad properly.

Sets how long the actuator should hold the same position.

Note: For most tamp applications, this value should be zero. For slow line speed applications, this value can be used to keep the pad in contact with the product longer, but with weaker (non-crushing) force. Holds the last position, versus continuing forward.

See chart below for recommended setting:

Profile	Label
Low	Label length > 203,2mm (8")
Med-Low	Label length > 203,2mm (8")
Medium	Label size closely matches pad size (i.e., 101,6mm x 152,4mm [4" x 6"] label on 101,6mm x 152,4mm [4" x 6"] pad)
Med-High	Label area is smaller than pad size by 50% (i.e., 101,6mm x 50,8mm [4" x 2"] label on 101,6mm x 101,6mm [4" x 4"] pad)
High	Label area is smaller than pad area by 70% (may require custom pad to accommodate)

E-TAMP/BLOW Mechanical Setup

ALIGN TO PEEL BLADE

1. Loosen both screws on the dovetail slider (A).
2. Slide actuator assembly toward and away from peel blade until there is approximately 3,2mm (1/8") gap.
3. Tighten both screws (A).

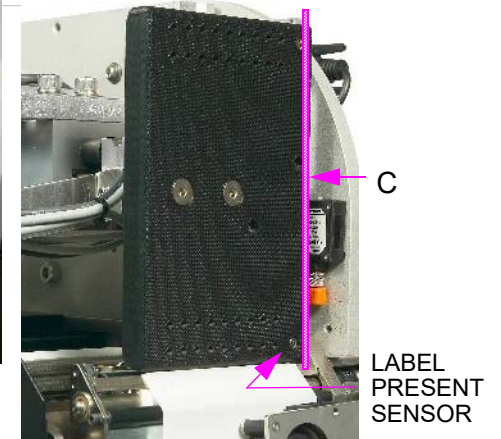
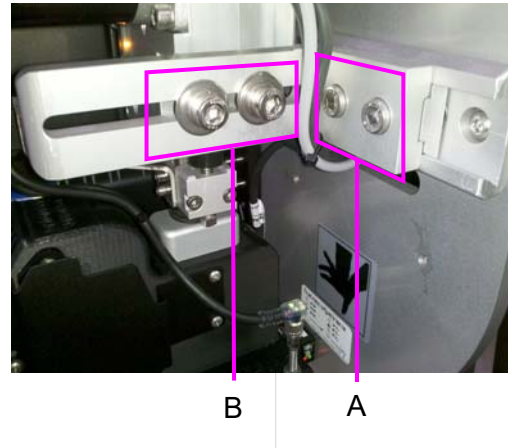

ALIGN LABEL WITH TAMP PAD

1. Loosen both screws on the tamp actuator L-bracket (B).
2. Slide the actuator assembly toward and away from the baseplate until the label present sensor will be covered by a fed label.
3. Tighten both screws on the tamp actuator L-bracket (B).

ALIGN TAMP PAD HEIGHT

1. Loosen the jam screw on the actuator rod.
2. Adjust the bumper height by turning the bumper so that the face of the peel blade is 1,6mm (1/16") **BEYOND** the peel blade.
3. Power on the Label Applicator to verify tamp pad home position.
4. Tighten the jam screw.

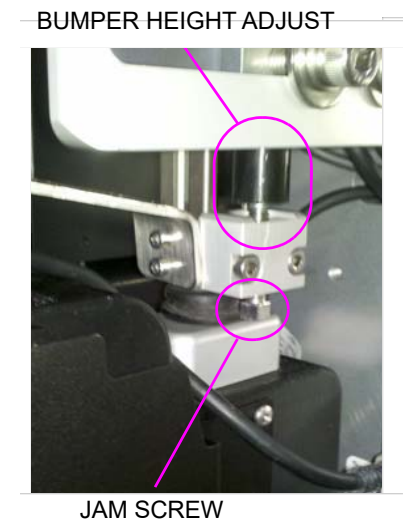
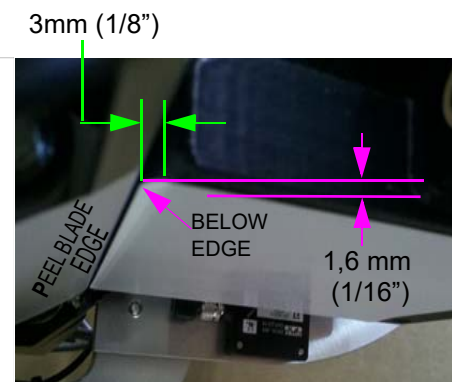

E-TAMP/BLOW Parameter Setup

E-TAMP/BLOW applications allow the label to be placed on the Top or Side of a product. Typically, the label is transferred in a contact-less manner to the product. Alternatively, the tamp pad can make contact with the product and then blow (tamp-touch-blow) to help place a label into a recess or void area.



LABEL MENU - Enter LABEL Menu from the Home Screen.

Std for rectangular labels with 3,2mm (1/8") gap or **Odd** for any shape label that passes gap sensor.

Sets the amount of tension applied to the rewind on a feed cycle. Set lower for speeds less than 508mm/s (100 FPM) or labels shorter than 101,6mm (4").

Sets the distance the label will travel after gap sensor is triggered. For standard labels usually set to 12,7mm to 19,1mm (0.5" to 0.75").



Determines the label generation mode. For slow applications, like pallets, make this **P1 Detect**. This will reduce the time the label adhesive is exposed to air and drying. For highest throughput, use **At Home**. Use **P2 Detect** for the highest accuracy (by using two detectors) when feed on demand is required. **Then Apply** feeds a label when actuator is at Home position, then applies immediately.

Depends on the product speed and PPM. Set for fastest throughput for the application.



SYSTEM MENU - Enter SYSTEM Menu from the Setup Menu.

Sets the rewind motor direction.

Set to the length of the actuator.

Sets the direction of the Actuator motor. This setting matches the A/B configuration of the actuator.



E-Tamp will be chosen for this application.

Yes will offset the label placement from the front. If the product lengths vary, and the label needs to be placed off of the trailing edge of the product, set to **No**.



SMART MENU - Enter SMART Menu from the Setup Menu.

Determines if the system is being used with the optional Label Present sensor.

Determines measurement units (Standard or Metric).

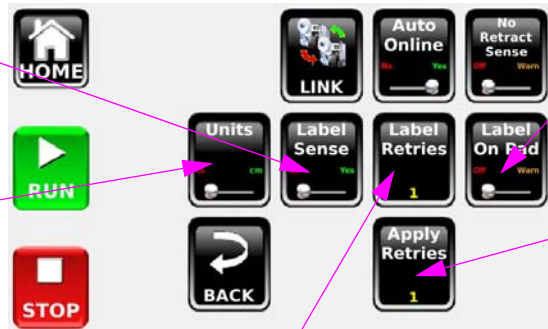

Provides a warning if the system is online with a prior label on the tamp pad. Helps avoid a potential label to product mismatch.

Determines how many times the system will attempt to apply the same label. The available options are **1, 2, 3** and **Infinite**. To ensure a 1 Label to 1 Product match, set this to 1.

Determines how many times the label will be fed without an application. The available options are **1, 2, 3** and **Infinite**. To ensure a 1 Label to 1 Product match, set this to 1.



SETUP/JOB MENU - Enter JOB Menu from the Setup Menu.

No disables the Blow function (E-TAMP). **On Sensor** only activates the Blow function when the product is detected by Auto Retract Sensor. **On Retract** activates the Blow function when the actuator is returning due to Apply Duration expiring.

Keep as small as possible by locating the product sensor as close to the peel blade as possible. Exception - if print on demand is used.

Controls the extension stroke time. Set Auto-Retract to zero to properly adjust this time, then re-enable Auto Retract.



Most E-Tamp applications will not need much Home Delay. Large label sizes will benefit with a minimal delay of 20 mS to 100 mS.

If installed, the Auto-Retract (AR) time depends on the Actuator Speed. Typical values range from 1 mS to 100 mS.

ACTUATOR SETUP MENU

Press **ACTUATOR SETUP** from the SETUP/JOB Menu.

Sets the furthest extension of the tamp for the application with steps of one inch. Set distance just short of the product to blow label to the product.

Sets the furthest extension of the tamp with 6mm (1/4") steps.

Sets the overall speed of the Actuator to five discrete values.

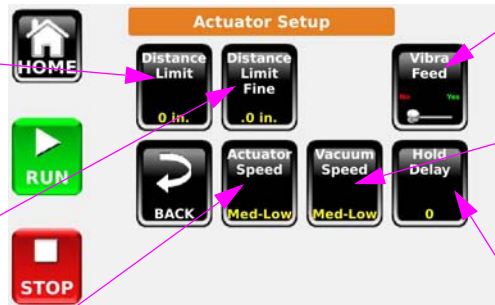

If enabled, the pad vibrates during label feed to help thicker labels or with stronger adhesive feed on the pad properly.

Vacuum Speed should be **Med_High** or **High**.

Sets how long the actuator should hold the same position once it reaches the first of these conditions: Apply Duration expired, Auto Retract sensed, Distance Limit threshold reached.

Note: Use this delay to keep the tamp pad at a fixed distance while the blow function is operating. A value between 50 mS and 100 mS makes the blow more effective.

High Speed Tamp Mechanical Setup

ALIGN TO PEEL BLADE

1. Loosen the two screws on the dovetail slider (A).
2. Slide assembly toward and away from the drive module until there is approximately 3,2mm (1/8") gap between the drive module peel blade and tamp pad edge.
3. Tighten the two screws (A).

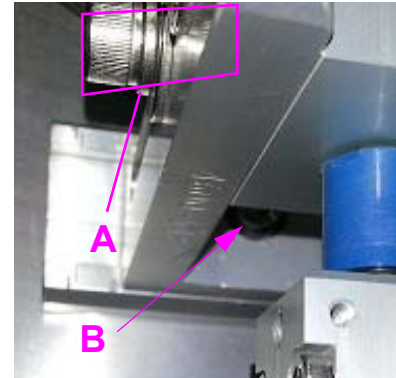

ALIGN LABEL WITH TAMP PAD

1. Loosen the two screws on the L-bracket (B).
2. Slide the assembly toward and away from the baseplate until a fed label will cover the label present sensor.
3. Tighten the two screws on the L-bracket (B). Keep the actuator parallel to the baseplate during tightening.

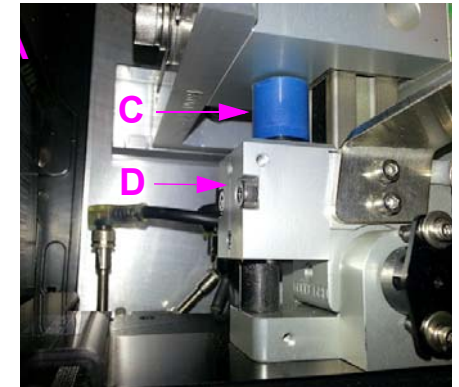

ALIGN TAMP PAD HEIGHT

1. Loosen the set screw (D).
2. Adjust the bumper height (C) by turning the bumper so that the face of the peel blade is 1,6mm (1/16") **BEYOND** the peel blade.
3. Tighten the set screw (D).
4. Loosen the screws (E).
5. Slide the roller to set angle. The pad face should be level to the bottom edge of the baseplate.
6. Tighten the screws (E).



High Speed Tamp Parameter Setup

High Speed Tamp (HST) applications allow the label to be placed on the Top or Side of a product. Typically, this application method allows for line speeds higher than a standard tamp module can handle. The actuator extends the pivoting plate down to the product and holds this position to allow the product to receive the label via the roller.

Alternatively, the HST can be used to follow the contour of the product. The same principles apply: the plate should not be setup to make flat contact with the product, but rather stop short, hold position, and let the pivoting-action of the tamp plate glide along the product's surface.

LABEL MENU - Enter LABEL Menu from the Home Screen.

Std for rectangular labels with 3,2mm (1/8") gap or **Odd** for any shape label that passes gap sensor.

Sets the amount of tension applied to the rewind on a feed cycle. Set lower for speeds less than 508mm/s (100 FPM) or labels shorter than 101,6mm

Sets the distance the liner has to travel after the gap for the next label to align at the edge of peel blade. For standard labels usually set to 12,7mm to 19,1mm (0.5" to 0.75").

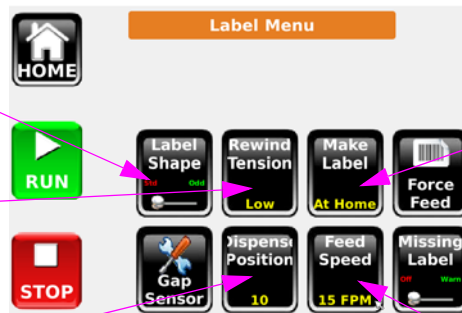

Determines the label generation mode. For slow applications, like pallets, make this **P1 Detect**. This will reduce the time the label adhesive is exposed to air and drying. For highest throughput, use **At Home**. Use **P2 Detect** for the highest accuracy (by using two detectors) when feed on demand is required. **Then Apply** feeds a label when actuator is at Home position, then applies immediately.

Depends on the product speed and PPM. Set for fastest throughput for the application.

SYSTEM MENU - Enter SYSTEM Menu from the Setup Menu.

Sets the rewind motor direction.

Set to the length of the actuator.

Sets the direction of the actuator motor. This setting matches the A/B configuration of the actuator.

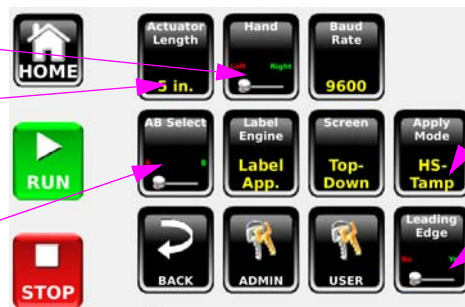

HS-Tamp will be chosen for this application.

Yes will offset the label placement from the front. If the product lengths vary, and the label needs to be placed off of the trailing edge of the product, set to **No**.

SMART MENU - Enter SMART Menu from the Setup Menu.

Determines if the system is being used with the optional Label Present sensor.

Determines measurement units (Standard or Metric).

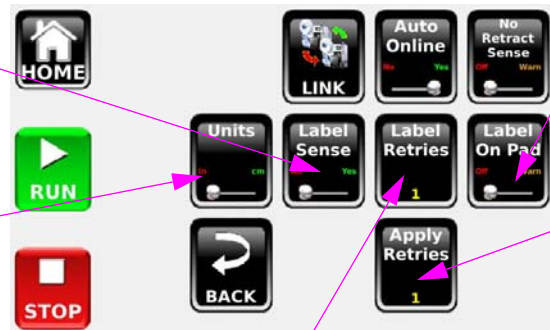

Provides a warning if the system is online with a prior label on the tamp pad. Helps avoid a potential label to product mismatch.

Determines how many times the system will attempt to apply the same label. The available options are **1**, **2**, **3** and **Infinite**. To ensure a 1 Label to 1 Product match, set this to 1.

Determines how many times the label will be fed without an application. The available options are **1**, **2**, **3** and **Infinite**. To ensure a 1 Label to 1 Product match, set this to 1.

SETUP/JOB MENU - Enter JOB Menu from the Setup Menu.

Keep as small as possible by locating the product sensor as close to the peel blade as possible. Exception - if print on demand is used.

Controls the extension stroke time. Set Auto-Retract to zero to properly adjust this time, then re-enable Auto Retract.

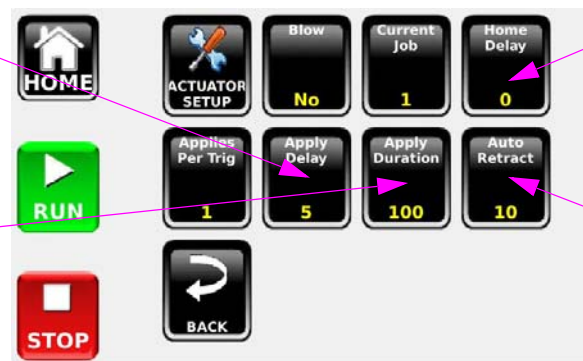

Most E-Tamp applications will not need much Home Delay. Large label sizes will benefit with a minimal delay of 20 mS to 100 mS.

If installed, the Auto-Retract (AR) time depends on the Actuator Speed. Typical values range from 1 mS to 100 mS.

ACTUATOR SETUP MENU

Press **ACTUATOR SETUP** from the SETUP/JOB Menu.

If enabled, the pad vibrates during label feed to help thicker labels or with stronger adhesive feed on the pad properly.

Sets the furthest extension of the tamp for the application with steps of one inch. Use this limit if the product distance to the labeler is consistent.

Sets the furthest extension of the tamp with 6mm (1/4") steps.

Sets the overall speed of the Actuator to five discrete values.

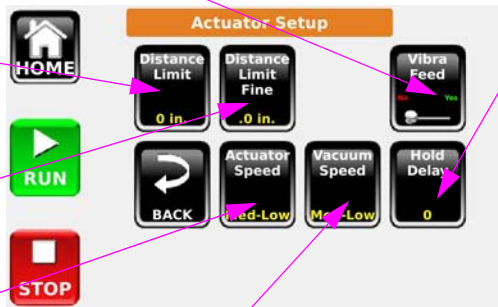

Sets how long the actuator should hold the same position once it reaches the first of these conditions: Apply Duration expired, Auto Retract sensed, Distance Limit threshold reached.

Note: For CONTOURING APPLICATIONS use the Distance Limit to set the fixed position to pivot from and increase the Hold Delay to apply all of the label. May need to increase Apply Duration to keep actuator in position for the whole Hold period.

Note: For HIGH-SPEED APPLICATIONS minimize stroke length and hold time. Keep the tamp plate engaged to the roller bumper, and extend just long enough to pivot. Lower Actuator Speeds are better for this action.

See chart below for recommended setting:

Profile	Label
Low	Label length > 203,2mm (8")
Med-Low	Label length > 203,2mm (8")
Medium	Label size closely matches pad size (i.e., 101,6mm x 152,4mm [4" x 6"] label on 101,6mm x 152,4mm [4" x 6"] pad)
Med-High	Label area is smaller than pad size by 50% (i.e., 101,6mm x 50,8mm [4" x 2"] label on 101,6mm x 101,6mm [4" x 4"] pad)
High	Custom pads of smaller label sizes

E-FASA Mechanical Setup

PEEL BLADE GAP ADJUSTMENT

1. Loosen the four screws on the dovetail slider (A).
2. Slide assembly toward and away from the peel blade until there is approximately 3,2mm (1/8") gap between the peel blade and tamp pad edge.
3. Tighten the four screws (A).

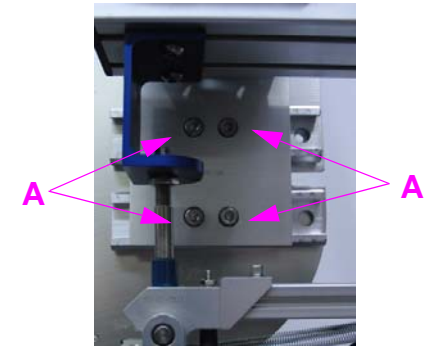

BASEPLATE ADJUSTMENT

1. Loosen the four screws on the L-bracket (B).
2. Slide E-FASA assembly toward and away from the baseplate until a fed label will cover the label present sensor.
3. Tighten the four screws on the L-bracket (B).

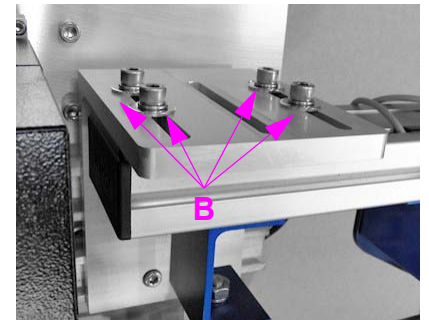

HEIGHT POSITION ADJUSTMENT

1. Loosen the jam nut (C).
2. Set height by rotating bumper rod (D).
3. Adjust the tamp pad height to 1,6mm (1/16") **BEYOND** the peel blade.
4. Check home position by powering up the system.
5. Tighten the jam nut (C).

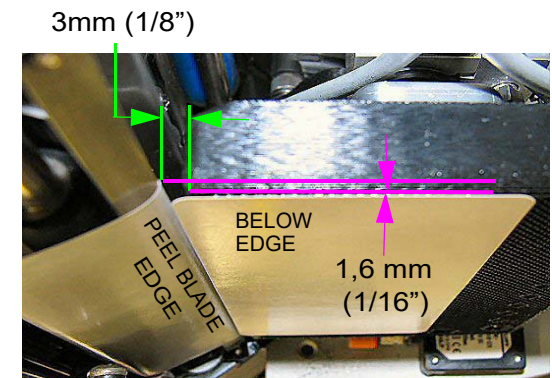
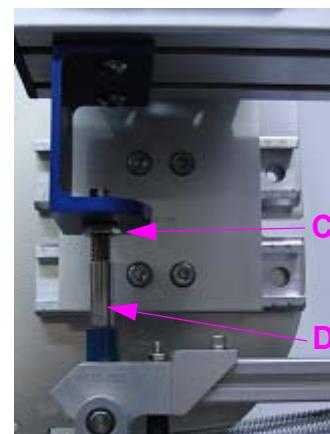

PAD ANGLE ADJUSTMENT

1. Loosen the jam nut (E).
2. Tighten or loosen the bumper (F) to rotate the pad, making it parallel with the baseplate.
3. Tighten the jam nut (E).

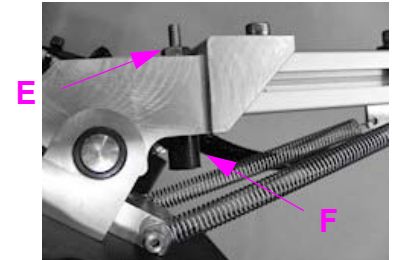

PIVOT SPRING TENSION ADJUSTMENT

1. Loosen bolt (G).
2. Slide the bracket closer or further from the rod end to loosen or tighten the spring.
3. Tighten bolt (G).
4. Test label application. Pad should not “slap” the product when labeling.

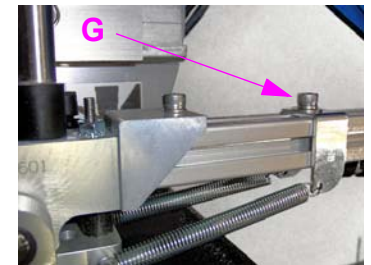

HOME SENSOR ADJUSTMENT

1. Loosen set screw (H).
2. With arm in home position, slide home sensor toward machine and then slowly slide it away from the machine until the light turns on.
3. Tighten set screw (H) to 0,68-0,90 N-m (6-8 LB-IN).
4. Verify that the home sensor light turns off when the pad is moved about 25,4mm (1”) away from the home bumper.

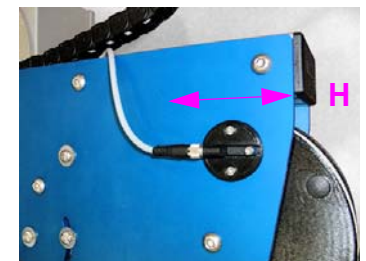

E-FASA Parameter Setup

The E-FASA application module allows for either one or two product panel applications. In single label applications, either the front or rear panels can be labeled. In dual label applications, either the front and side or side and rear panels can be labeled.

LABEL MENU - Enter LABEL Menu from the Home Screen.

Std for rectangular labels with 3,2mm (1/8") gap and **Odd** for any shape label that passes gap sensor.

Sets the amount of tension applied to the rewind on a feed cycle. Set lower for speeds less than 508mm/s (100 FPM) or labels shorter than 101,6mm (4").

Depends on the product speed and PPM. Set for fastest throughput for the application.

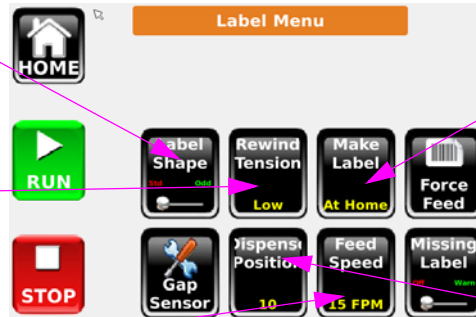

Determines the label generation mode. For slow applications, like pallets, make this **P1 Detect**. This will reduce the time the label adhesive is exposed to air and drying. For highest throughput, use **At Home**. Use **P2 Detect** for the highest accuracy (by using two detectors) when feed on demand is required. **Then Apply** feeds a label when actuator is at Home position, then applies immediately.

Sets the distance the liner has to travel after the gap for the next label to align at the edge of peel blade. For standard labels usually set to 12,7mm to 19,1mm (0.5" to 0.75").

SYSTEM MENU - Enter SYSTEM Menu from the Setup Menu.

Set to the length of the actuator.

Note: This is an important setting, since it regulates the overall speed of the arm. Faster speeds are allowable for the 12cm (5") arm and reduced for the 25cm (10") and 50cm (20"). Proper function of the system requires the correct match of the Actuator Length and the physical length of the E-FASA arm. The length of the E-FASA is the usable length of the arm, measured between the baseplate edge and the tamp pad center. For 19cm (7.5"), set to 25cm (10"); for 38cm (15"), set to 50cm (20").

Sets the rewind motor direction.

Sets the direction of the Actuator motor. This setting matches the A/B configuration of the actuator and is different with different applications



E-FASA will be chosen for this application.

Yes will offset the label placement from the front. If the product lengths vary, and the label needs to be placed off of the trailing edge of the product, set to **No**.

SMART MENU - Enter SMART Menu from the Setup Menu.

Determines if the system is being used with the optional Label Present sensor.

Determines how many times the label will be printed/fed without an application. The available options are **1, 2, 3** and **Infinite**. To ensure a 1 Label to 1 Product match, set this to 1.

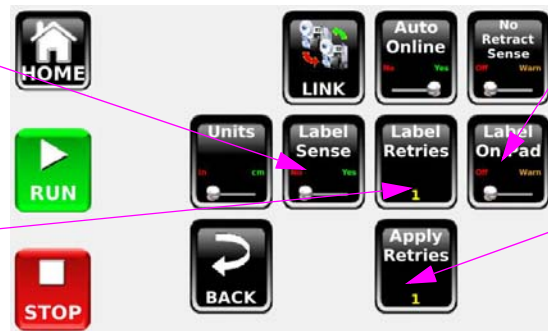

Provides a warning if the system is online with a prior label on the tamp pad. Helps avoid a potential label to product mismatch.

Determines how many times the system will attempt to apply the same label. The available options are **1, 2, 3** and **Infinite**. To ensure a 1 Label to 1 Product match, set this to 1.

SETUP/JOB MENU - Enter JOB Menu from the Setup Menu.

If the application requires two labels, front and side panels, this delay can be kept minimal. If the application is side and rear panels, the product sensor will have to be relocated, and delay will therefore need to increase.

Should be greater than the time required to print two labels (if using Make Label PD Sensor 1 or 2) or print one label (Make Label = At Home mode) plus the first apply cycle.

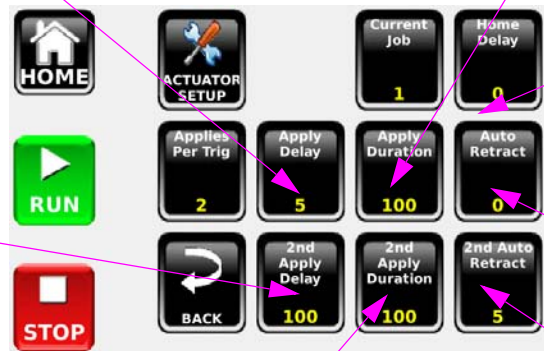

Should be incrementally set from low values to higher values to adjust the contact point with the product. For the front or rear panels, the optimum contact point is a little beyond 90 degrees. This allows the pad to pivot, and place the label squarely on the product.

Most E-FASA applications benefit from some minimal delay between 50 mS to 200 mS, to allow the pad to settle when arriving home.

Not very useful for the front and rear panels, but mainly used for the side application. Values between 1mS and 50 mS are typical.

Values between 1 mS and 50 mS are typical.

Same as Apply Duration.

ACTUATOR SETUP MENU

Press **ACTUATOR SETUP** from the SETUP/JOB Menu.

Sets the furthest swing angle for this application.

Note: Use this limit for the front or rear panel swing (typically 90 degrees). Can be used in conjunction with the Hold Delay to swing out and wait for the product's front panel. If Hold Delay is long enough, will perform a corner wrap on product.

Sets the overall speed of the Actuator to five discrete values.

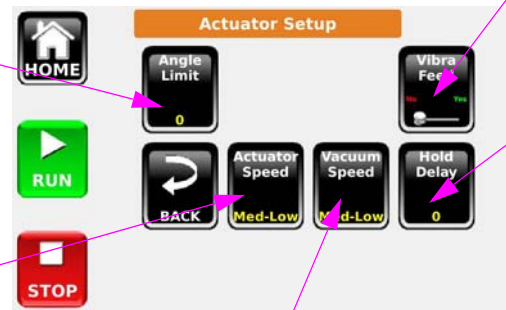

If enabled, the pad vibrates during label print/feed to help thicker labels or with stronger adhesive feed on the pad properly.

Sets how long the actuator should hold the same position once it reaches the first of these conditions: Apply Duration expired, Auto Retract sensed, Angle Limit threshold reached.

See the chart below for recommended setting:

Profile	Label
Low	Label length > 203,2mm (8")
Med-Low	Label length > 203,2mm (8")
Medium	Label size closely matches pad size (i.e., 101,6mm x 152,4mm [4" x 6"] label on 101,6mm x 152,4mm [4" x 6"] pad)
Med-High	Label area is smaller than pad size by 50% (i.e., 101,6mm x 50,8mm [4" x 2"] label on 101,6mm x 101,6mm [4" x 4"] pad)
High	Custom pads of smaller label sizes

E-WASA Mechanical Setup

ADJUST “X” POSITION

1. Loosen the two screws on the slider track (A).
2. Slide the WASA module until there is approximately 3,2mm (1/8”) between the peel blade and the edge of the Fan Box.
3. Tighten the screws (A).

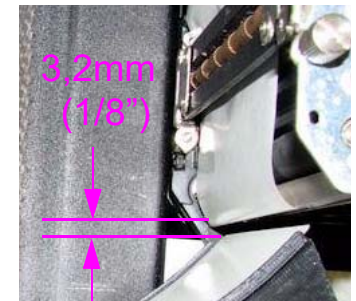
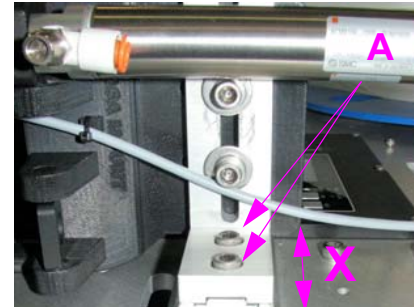

ADJUST “Y” POSITION

1. Loosen the two screws (B).
2. Feed a label out to the fan box.
3. Label should dispense within 3,2mm (1/8”) of raised edge, but **NOT** on the raised edge.

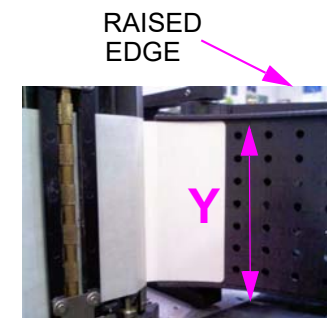
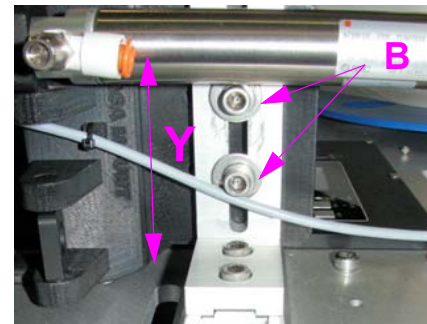

ADJUST ROTATION ANGLE “Z” POSITION

1. Loosen two nuts (C) on the cylinder.
2. Turn the cylinder body to thread the rod in or out of the coupling to adjust the “Z” rotational position of the Fan Box.
3. Adjust the rotation so that the label feeds out to the Fan Box without stalling on the surface of the face.
4. Tighten both nuts (C) and feed a few labels to determine if the position is ideal.

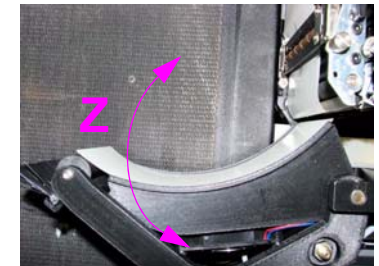
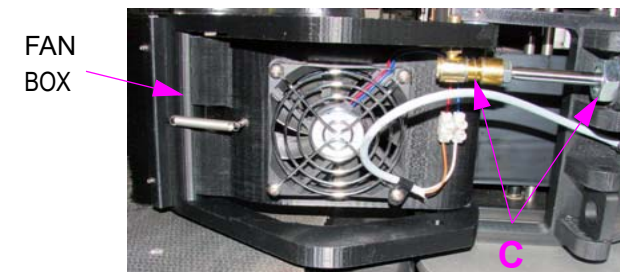

ADJUST SPRING RATE

1. Loosen the jam nut with a 13mm open-end wrench.
2. Turn the Screw Adjustment clockwise to increase the spring force, and counterclockwise to reduce it. Products that are under 2,3~4,5 kg (5~10 lbs) require less spring force to allow the label to be wrapped without making the product stall on the conveyor. Too light of a spring tension will result in a poorly wrapped label. The full range of spring tension is accomplished within a 50,8mm (2") screw threading distance.



WARNING: Do not decrease the spring tension so far that the WASA Fan Box does not consistently return home. If the spring is too weak, friction and product placement will begin to effect the performance of the label wrap.



NOTE: The E-WASA is highly dependent on a rear guide rail for optimal performance. Since the E-WASA is spring-loaded to apply pressure to the front and side of the product, the guide rail prevents possible product skew. Operation without the proper material handling will result in poor wrap angle or label wrinkle.

3. When the WASA travel has been checked for the swing range of motion, lock in the spring tension position by tightening the jam nut.

ADJUST RETURN FLOW CONTROL

Loosen the thumb wheel jam nub and turn the flow control clockwise to reduce the speed that the WASA returns to the home position. Increase the flow by turning the control counterclockwise, which will allow the WASA box to return home faster.



WARNING: The adjustment on the return speed will determine the maximum throughput rate. If the application can tolerate a slower return rate, it will result in a smoother and gentler return, which will result in longer life.



NOTE: The E-WASA is highly dependent on a rear guide rail for optimal performance. Since the E-WASA is spring-loaded to apply pressure to the front and side of the product, the guide rail prevents possible product skew. Operation without the proper material handling will result in poor wrap angle or label wrinkle.

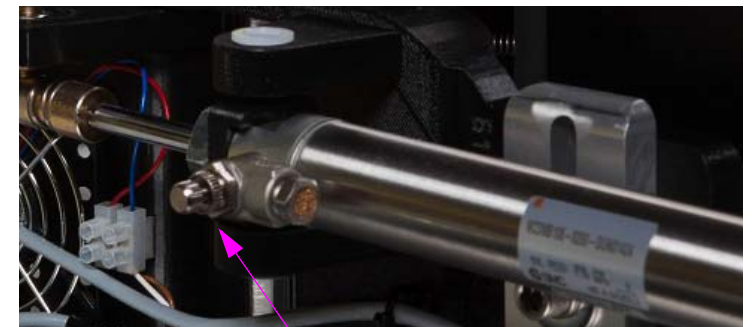
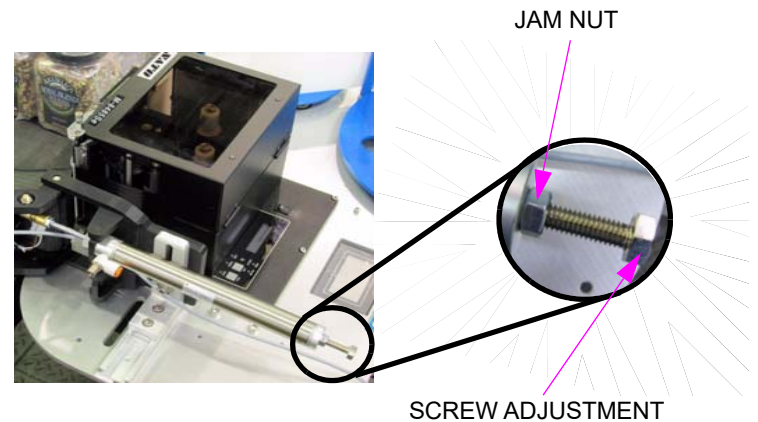

E-WASA Parameter Setup

E-WASA applications allow the label to be placed on two adjacent panels, typically front and side, but front and top is also possible. Since the E-WASA cannot accept the next label until the arm returns home, it is a label print on demand by default.

LABEL MENU - Enter LABEL Menu from the Home Screen.

Std for rectangular labels with 3,2mm (1/8") gap and **Odd** for any shape label that passes gap sensor.

Sets the amount of tension applied to the rewind on a print cycle. Set lower for feed speeds less than 508mm/s (100 FPM).

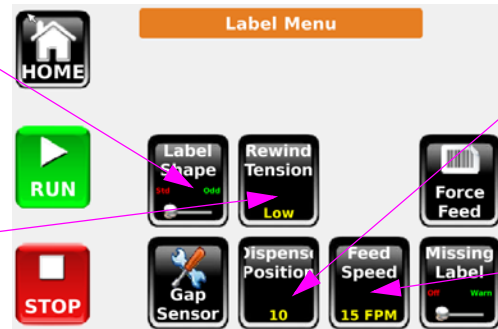

Sets the distance the liner has to travel after the gap for the next label to align at the edge of peel blade. For standard labels usually set to 12,7mm to 19,1mm (0.5" to 0.75").

Depends on the product speed and PPM. Set for fastest throughput for the application.

SYSTEM MENU - Enter SYSTEM Menu from the Setup Menu.

Sets the rewind motor direction.

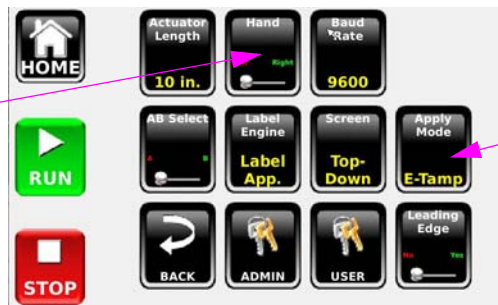

E-WASA, if there is no Home Sensor and **E-WASA+**, if there is a Home Sensor.

SETUP/JOB MENU - Enter JOB Menu from the Setup Menu.

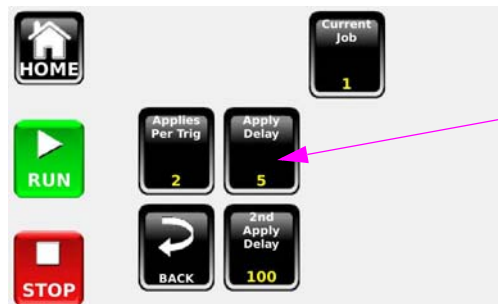

Determines the amount of time to delay from the product detector trigger to the label printing. Usually kept at a minimum value.

WIPE Mechanical Setup

ANGLE ADJUSTMENT

1. Loosen Rotator Screw (A).
2. Adjust angle.
3. Tighten Rotator Screw (A).

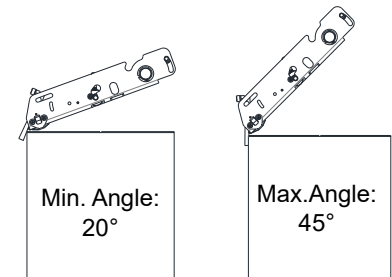
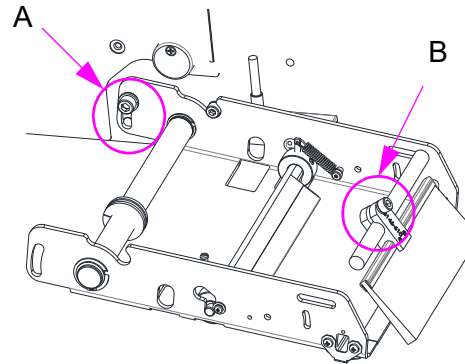

NOTE: Increase the angle to the product (more parallel feeding of label to product's surface) for surfaces that have an outward bow. Decrease the angle to the product (more perpendicular to the product's surface) for recessed areas or plastic-based labels that tend to trap air pockets.



NOTE: Using an angle less than 20° or greater than 45° can cause label misplacement or unnecessary wear on applicator.

BRUSH ANGLE AND POSITION ADJUSTMENT

The brush should be positioned at the point where the label will make contact with the product.

1. Loosen the brush clamp handle (B).
2. Position the brush to match the point of contact between the label and the product.
3. For short labels, the brush should be positioned next to or contacting the peel blade (product will push bristles back when in contact).



NOTE: If the brush is positioned too far away from the merge point, the label position consistency can change due to label slippage. In addition, the brush can curl up the front edge and, in certain conditions, can remove the label.

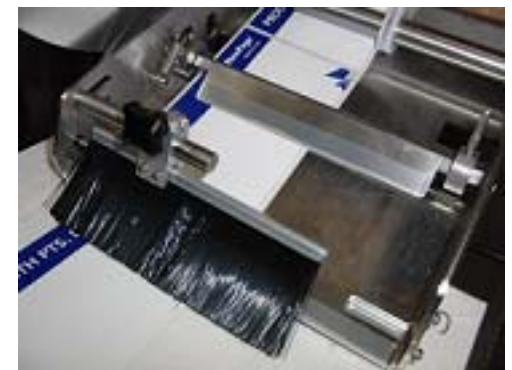

WIPE Parameter Setup

Wipe application allows for pre-printed standard and irregular labels to be applied at maximum speed of 150 cm/s (300 FPM).

LABEL MENU - Enter LABEL Menu from the Home Screen.

Std for rectangular labels with 3,2mm (1/8") gap or **Odd** for any shape label that passes gap sensor.

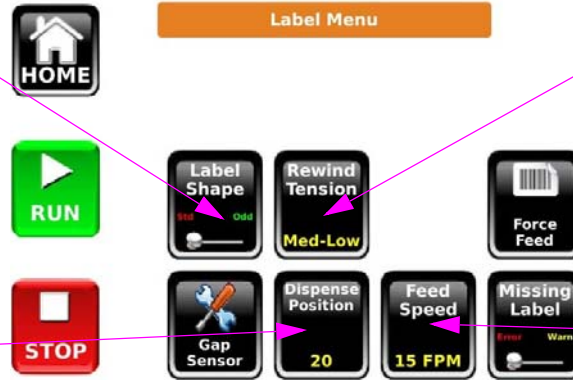

Sets the amount of tension applied to the rewind on a feed cycle. Set lower for speeds less than 508mm/s (100 FPM) or labels shorter than 101,6mm (4").

The distance liner has to travel after gap for the next label to align at the edge of peel blade. For standard labels usually set to 12,7mm to 19,1mm (0.5" to 0.75").

Depends on the product speed and PPM. Set for fastest throughput for the application.

SYSTEM MENU - Enter SYSTEM Menu from the Setup Menu.

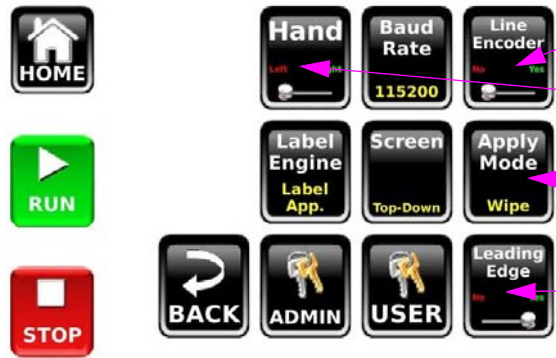

The SYSTEM MENU interface includes the following buttons and settings:

- HOME**: Home button (house icon)
- Hand**: Rewind motor direction (Left/Right indicator)
- Baud Rate**: 115200
- Line Encoder**: Set to NO
- Label Engine**: Label App.
- Screen**: Top-Down
- Apply Mode**: Wipe
- Leading Edge**: Set to No
- BACK**: Back button (curved arrow icon)
- ADMIN**: Admin button (key icon)
- USER**: User button (key icon)
- STOP**: Stop button (square icon)
- RUN**: Run button (play icon)

Callouts provide the following information:

- Set to NO for this application. (points to Line Encoder)
- Sets the rewind motor direction. (points to Hand)
- Wipe** is used for this application. (points to Apply Mode)
- Typically leading edge product triggers will offset the label placement from the front. If the product lengths vary, and the label needs to be placed off of the trailing edge of the product, set this value to No. (points to Leading Edge)

SETUP/JOB MENU - Enter JOB Menu from the Setup Menu.

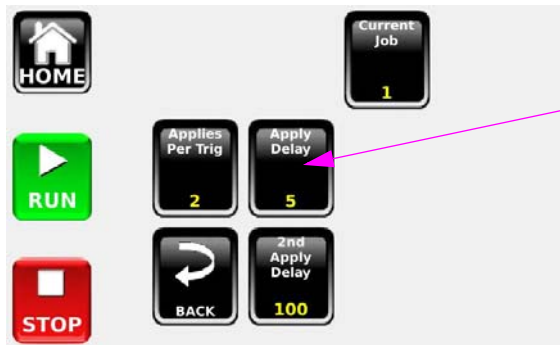

The SETUP/JOB MENU interface includes the following buttons and settings:

- HOME**: Home button (house icon)
- Current Job**: 1
- Applies Per Trig**: 2
- Apply Delay**: 5
- 2nd Apply Delay**: 100
- BACK**: Back button (curved arrow icon)
- STOP**: Stop button (square icon)
- RUN**: Run button (play icon)

Callout information:

- Determines the amount of time to delay from the product detector trigger to label feeding. The setting depends on feed speed and label placement on the product, but is usually kept at a minimum value. (points to Apply Delay)

WIPE - Line Encoder Enabled - Mechanical Setup

ANGLE ADJUSTMENT

1. Loosen Rotator Screw (A).
2. Adjust angle.
3. Tighten Rotator Screw (A).



NOTE: Increase the angle to the product (more parallel feeding of label to product's surface) for surfaces that have an outward bow. Decrease the angle to the product (more perpendicular to the product's surface) for recessed areas or plastic-based labels that tend to trap air pockets.



NOTE: Using an angle less than 20° or greater than 45° can cause label misplacement or unnecessary wear on applicator.

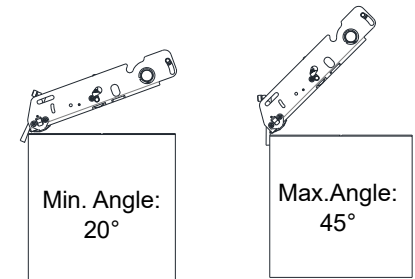
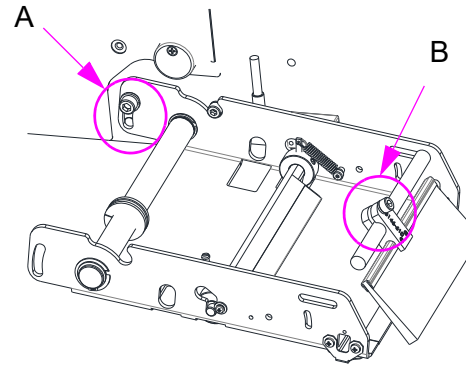

BRUSH ANGLE AND POSITION ADJUSTMENT

The brush should be positioned at the point where the label will make contact with the product.

1. Loosen the brush clamp handle (B).
2. Position the brush to match the point of contact between the label and the product.
3. For short labels, the brush should be positioned next to or contacting the peel blade (product will push bristles back when in contact).
4. Install the external encoder on the line so that the encoder wheel rides on the conveyor belt, close to labeler, to accurately read the speed of the product.

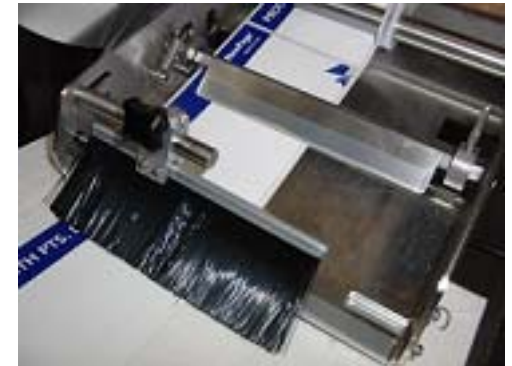

NOTE: If the brush is positioned too far away from the merge point, the label position consistency can change due to label slippage. In addition, the brush can curl up the front edge and, in certain conditions, can remove the label.



NOTE: It is recommended to install the Product Detector 25mm (1") to 102mm (4") from the edge of the peel blade to get the best label placement accuracy.

WIPE - Line Encoder Enabled - Parameter Setup

SYSTEM MENU - Enter SYSTEM Menu from the Setup Menu.

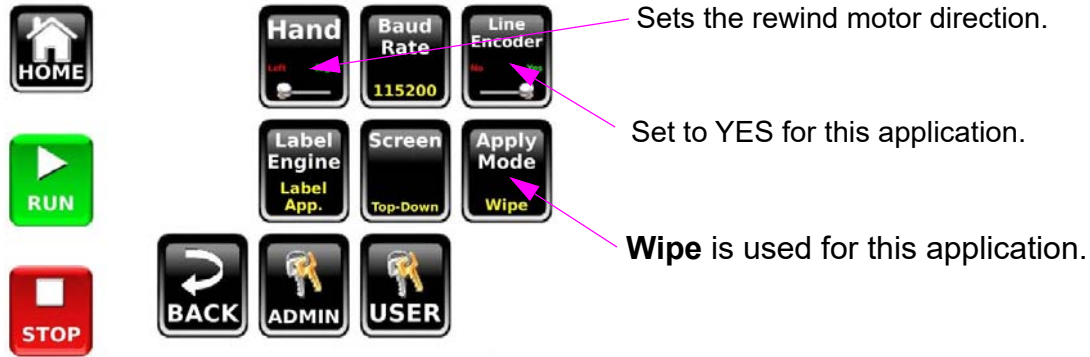

SETUP/JOB MENU - Enter JOB Menu from the Setup

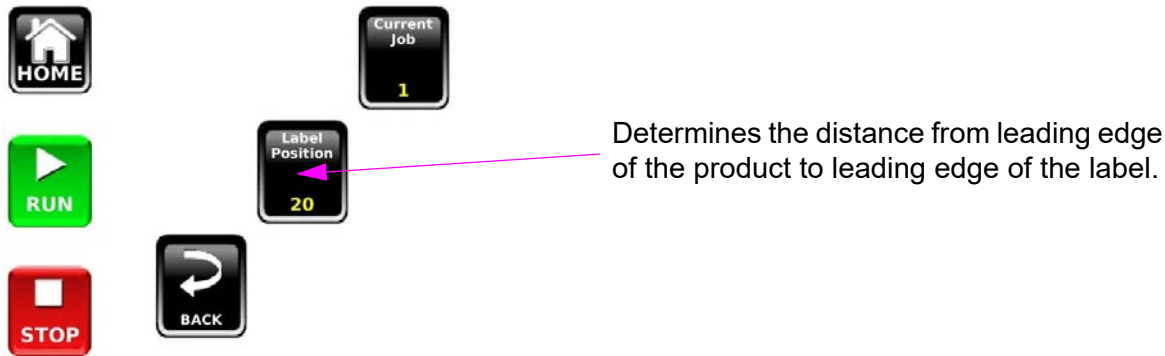

LABEL MENU - Enter LABEL Menu from the Home Screen.

Std for rectangular labels with 3,2mm (1/8") gap or **Odd** for any shape label that passes gap sensor.

Sets the distance of the product detector from edge of the peel blade. Minimum detector distance is 25mm (1").

The distance liner has to travel after gap for the next label to align at the edge of peel blade. For standard labels usually set to 12,7mm to 19,1mm (0.5" to 0.75").

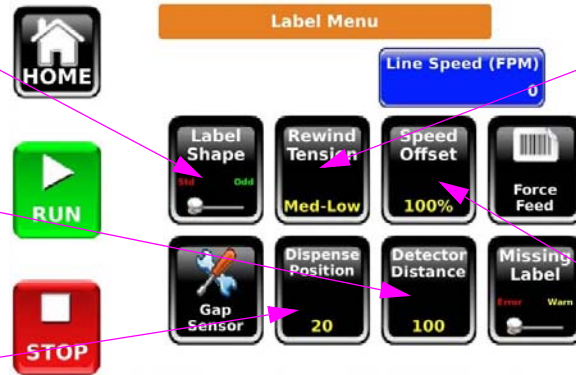

Sets the amount of tension applied to the rewind on a feed cycle. Set it to match the highest line speed/PPM. The rewind tension will match the lower speeds.

Adjusts the label feed speed by the set percentage. <100% decreases feed speed and >100% increases feed speed. To achieve better label placement accuracy for smaller labels, set the speed offset to values greater than 100%.

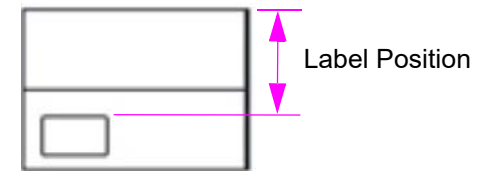
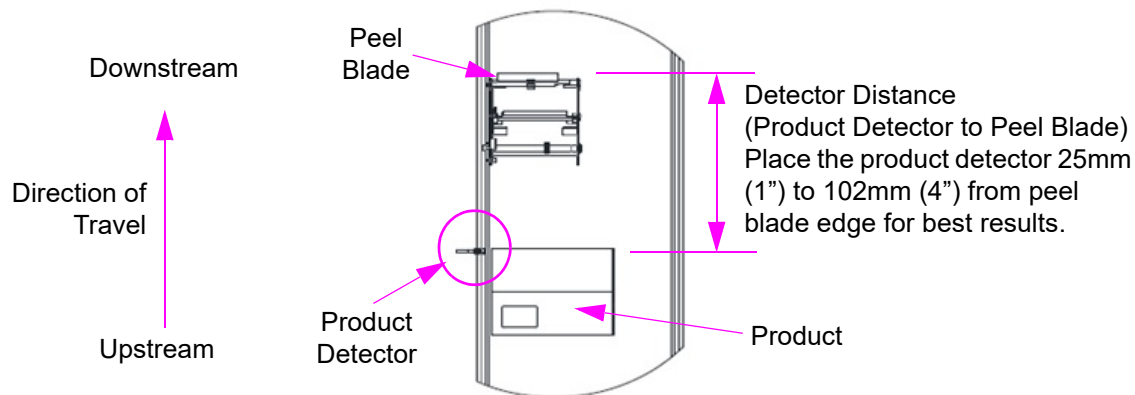

NOTE: It is recommended to install the product detector 25mm (1") to 102mm (4") upstream from the edge of the peel blade to get the best label placement accuracy.

Appendix C: Electrical Interface

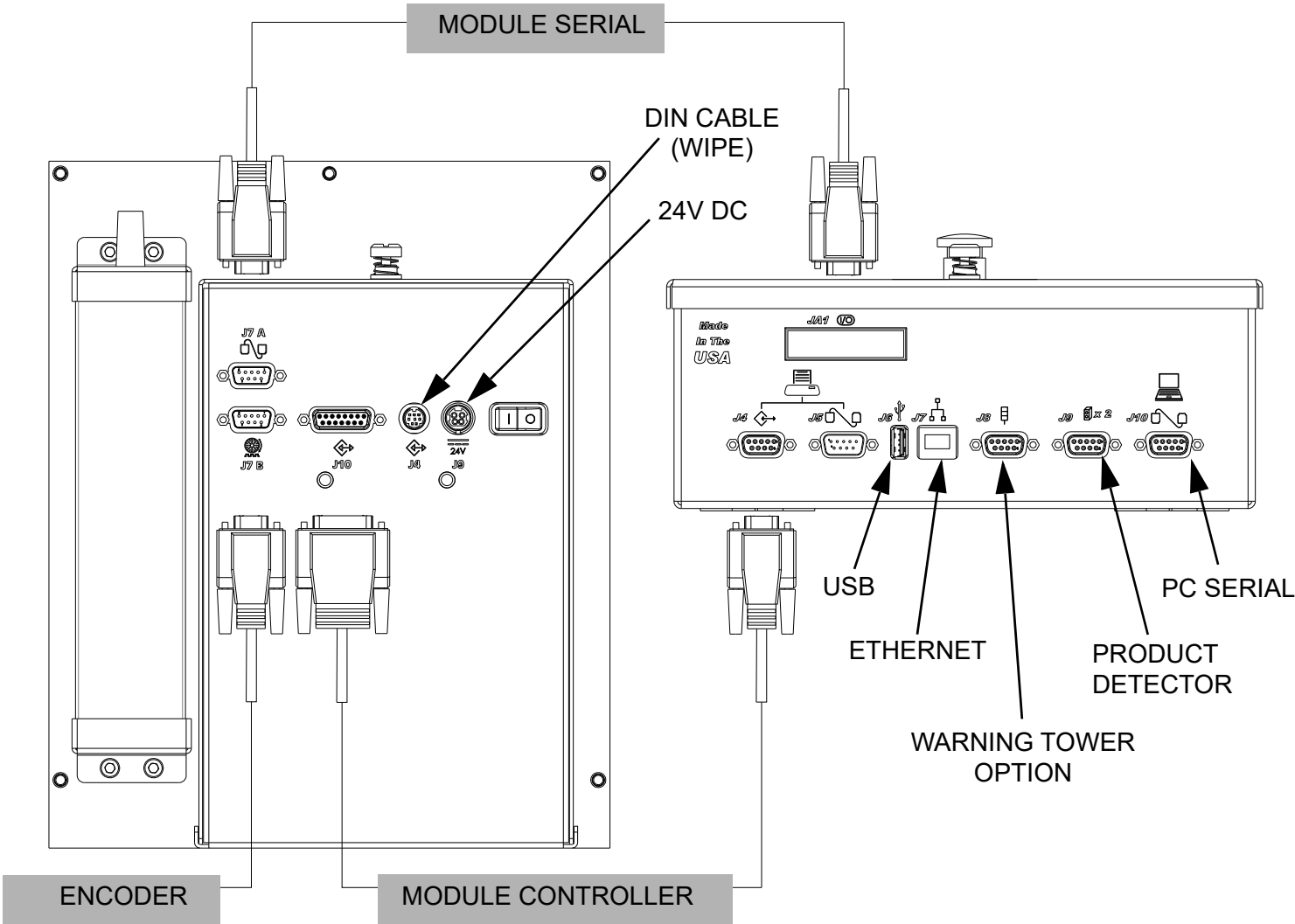

Appendix D: Language Support

The following languages are supported by the by the 7000 Series Printer Applicator:

User Interface (via Regional Settings)
Deutsch (German)
English
Español (Spanish)
Français (French)
Português (Portuguese)

Appendix E: Part Numbers

Replacement Kits

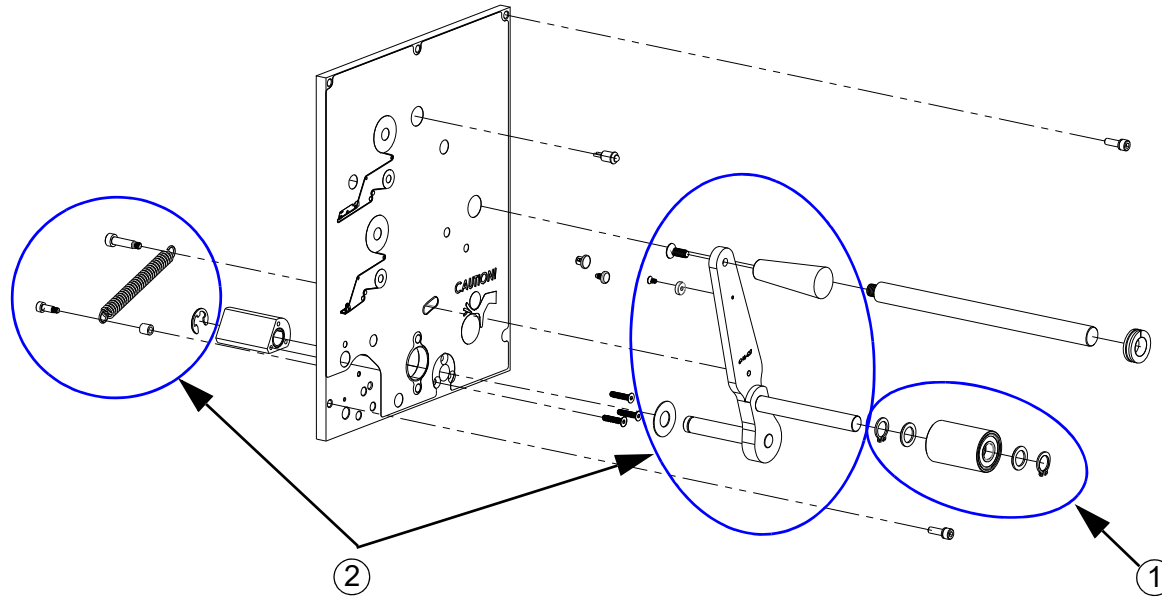

Item	Part No.	Description	Contents
1	404215	Nip Roller Assembly	(1) Nip Roller, (2) Washers and (2) Snap Rings
2	404216	Nip Roller Lever Assembly, Standard	Lever, Handle, Magnet, Fasteners, Retaining Ring, Spring and Standoff
	404217	Nip Roller Lever Assembly, Wide Web	

Replacement Kits (continued)

Motor Assembly Detail

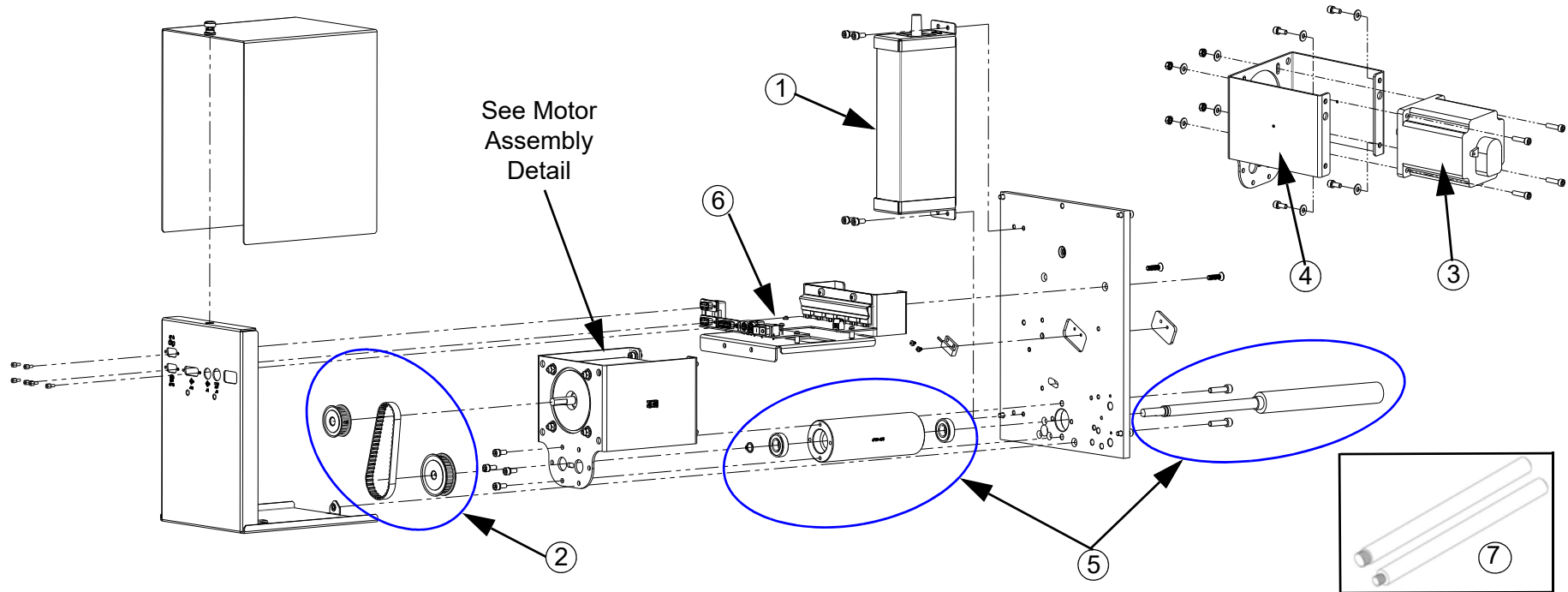

Item	Part No.	Description	Contents
1	404218	Kit, Power Supply	(1) Power Supply, (2) Power Supply Brackets and (4) Screws
2	404219	Kit, Drive Pulley Replacement	(1) 20 Groove Timing Pulley, (1) 28 Groove Timing Pulley and (1) Timing Belt
3	404205	Kit, Motor, 7000	(1) Motor, (4) Screws, (4) Nuts and (4) Washers
4	404206	Kit, Motor Mount, 7000	(1) Motor Mount Bracket, (1) Tie Mount and Mounting Hardware
5	404208	Kit, Drive Roller Assembly, Standard	(1) Driver Roller, (1) Drive Roller Housing, (2) Driver Roller Bearings, (1) Snap Ring and (2) Screws
	404209	Kit, Driver Roller Assembly, Wide Web	
6	404207	Kit, PC Board Mount Assembly, 7000	(1) Controller Board Assembly, (1) Hold-Down Mosfet, (1) Circuit Board Mount Assembly and (8) Screws
7	404224	Kit, Guide Rod	(1) Stainless Steel Guide Rod, M8 Thread, (1) Stainless Steel Guide Rod, M14 Thread

7000 Series Label Applicator

Service Parts

LA7000 Components

Item	Kit No.		Description
	Standard	Wide Web	
1	404220		Belt
2	404208	404209	Drive Roller Assembly
3	4750-203	4750-211	Tamp Peel Blade
4	4750-204	4750-212	Wipe Peel Blade
5	404210		PC Board
6	4750-206	4750-213	Hold-Down Parts
7	4750-207		4750/7000 Cable Assembly
8	404211	404212	Wear Items (Belt, Drive Assembly, Nip Roller)
9	6146-611	6146-682	Brush
10	4600-900		Product Detector Assembly, Diffuse
11	1901-141		AC Power Cable
12	4600-647		Rewind Clasp
13	6000-840		Container of Fasteners, 7000 Series
14	4750-235		Label Gap Sensor
15	4600-950		Standard Wear Items Kit (not pictured)
16	404223		Motor Assembly (not pictured)

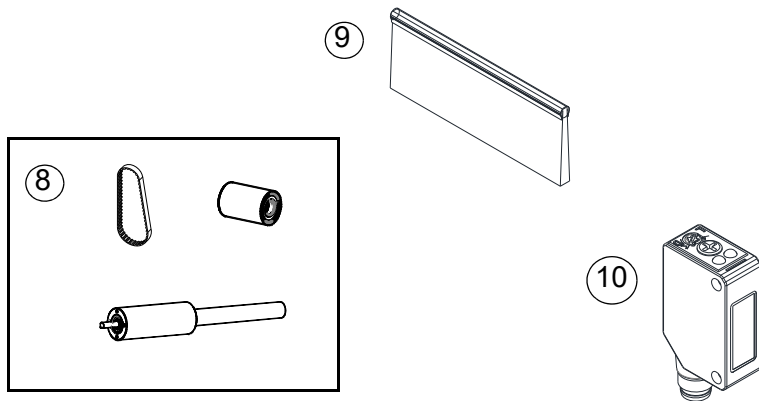
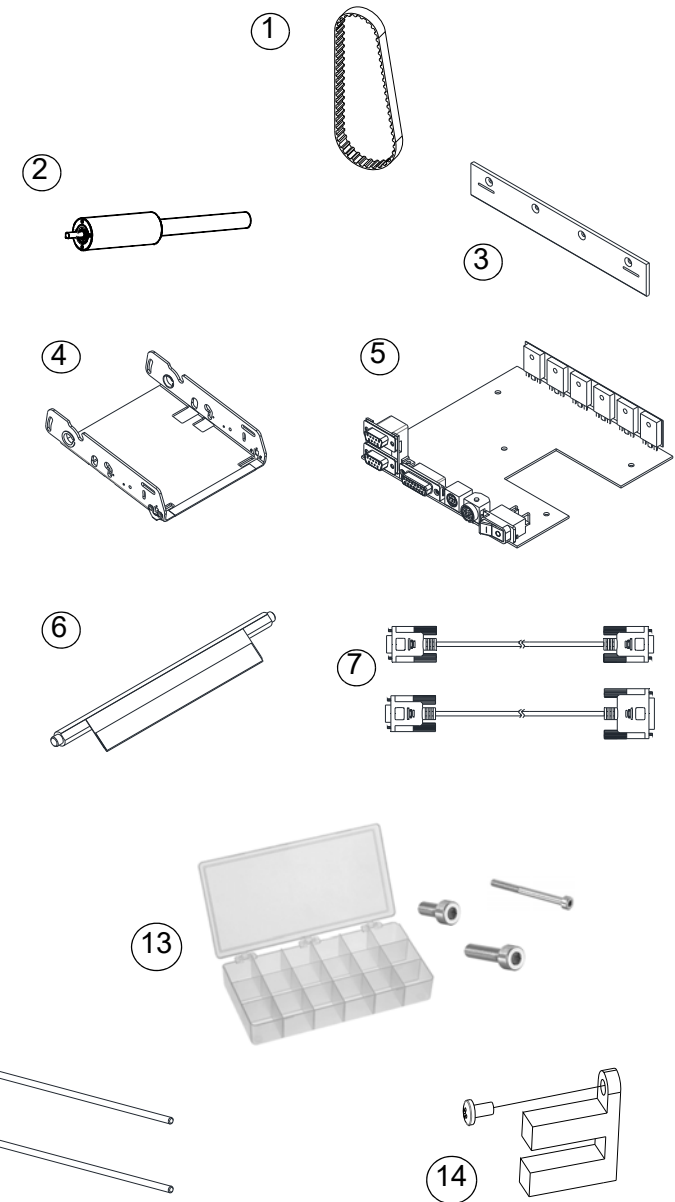

7000 Series Label Applicator

Applicator Components

Item	Kit No.	Description
1	6000-205X5	Actuator Extrusion, 127mm (5") Tamp
	6000-205X10	Actuator Extrusion, 254mm (10") Tamp
	6000-205X15	Actuator Extrusion, 381mm (15") Tamp
	6000-205X20	Actuator Extrusion, 508mm (20") Tamp
	6000-205X25	Actuator Extrusion, 635mm (25") Tamp
	6000-205X30	Actuator Extrusion, 762mm (30") Tamp
2	6000-698KIT	MCM Board Replacement
3	6000-950	E-TAMP Wear Items
4	6000-951	E-FASA Wear Items
5	6000-952	E-WASA Wear Items
6	4600-906	Home Sensor

NOTE: Pictures of items 3, 4 and 5 represent the Applicator, not the components in the Wear Items Kit.

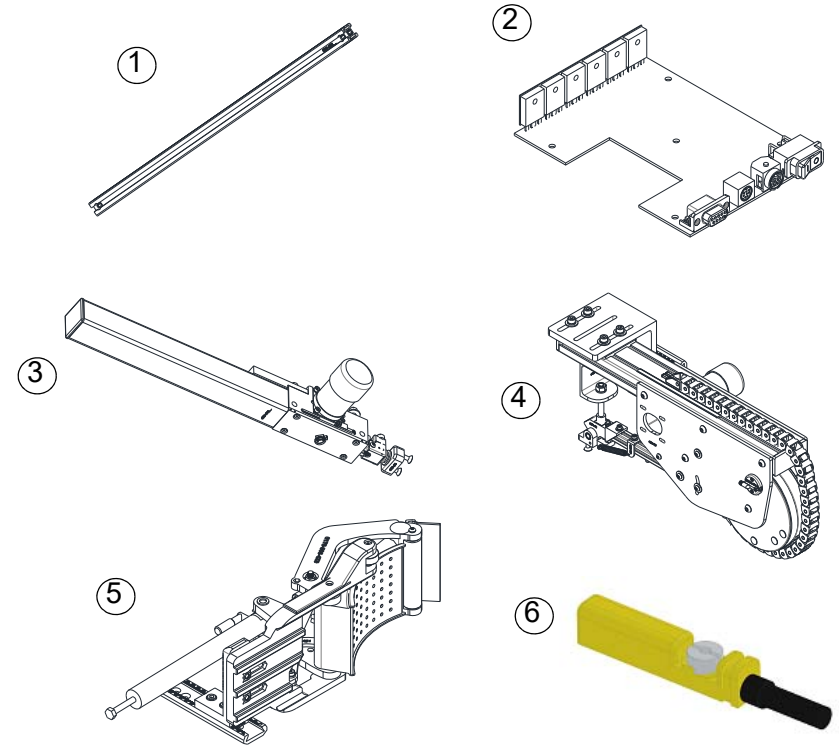

MCA Components

Item	Kit No.	Description
1	404200-LS7000	Display Assembly, LS7000
2	404202	Display Board and PC Board Assembly

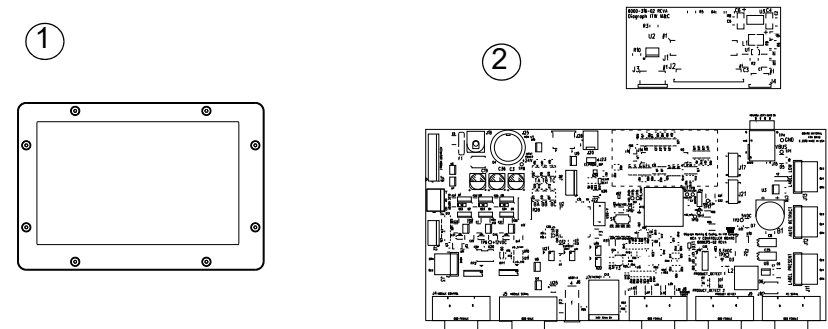

Optional Equipment

Item	Kit No.	Description
1	4600-901	Product Detector, Break-Beam
	4600-902	Product Detector, Laser
2	404214	Clear Label Gap Sensor (See Note below)
3	6000-518	Y-Cable, Product Detector
4	5780-017FXALP	Remote Hand-Held
5	404221	Parking Brake
6	6000-903	Auto Retract or Label Present Sensor
7	404226	Low Label Sensor with Bracket
8	4750-216	Core Adapter, 76,2mm to 152,4mm (3" to 6")
9	4750-215	Bracket & 152,4mm (6") Long Bristle Brush
10	6000828	LED Warning Light Tower
11	6000828AUD	Warning Tower, Audible
12	4600-625	Tie-Down Cleats, Standard CHI Stand (3 pack)
	401208	Tie-Down Cleats, RLC Heavy-Duty Stand (3 pack)
13	5760820-IJ	Encoder Assembly
14	5765-244	Levelers (4 pack)

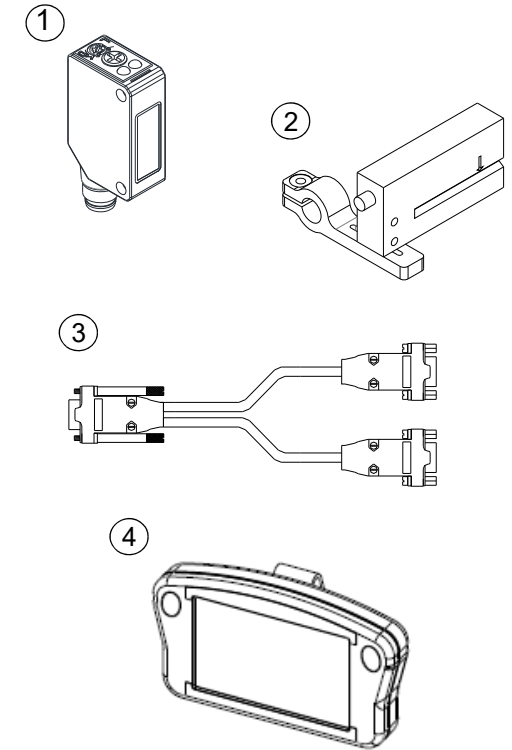

NOTE: Refer to Instruction Sheet 404214N for setup instructions for the Clear Label Gap Sensor.

